



HAYBUSTER[®]

H-106[™]

ROCK-EZE[™]

Serial Number 841085 & Up

**Operating Instructions
and Parts Reference**



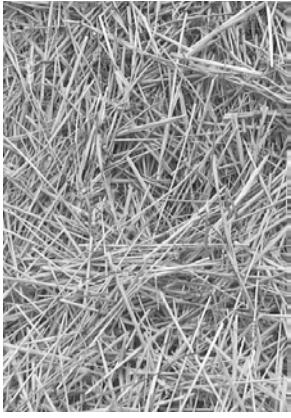

HAYBUSTER[®]
The Innovation Continues

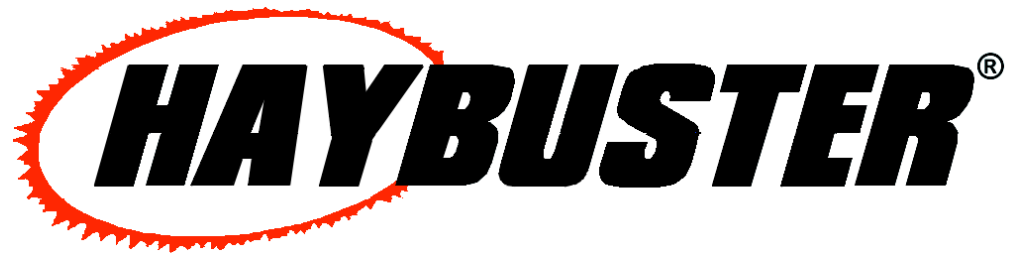
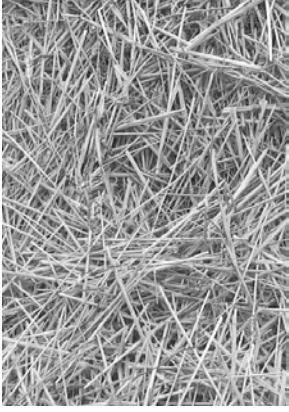



H-106TM **ROCK-EZETM**

Serial Number 841085 & Up

Operating Instructions and Parts Reference

DuraTech Industries International Inc. (DuraTech) has made every effort to assure that this manual completely and accurately describes the operation and maintenance of the H-106 ROCK-EZETM as of the date of publication. DuraTech reserves the right to make updates to the machine from time to time. Even in the event of such updates, you should still find this manual to be appropriate for the safe operation and maintenance of your unit.

This manual, as well as materials provided by component suppliers to DuraTech are all considered to be part of the information package. Every operator is required to read and understand these manuals, and they should be located within easy access for periodic review.

 **DURATECH**® and  are registered trademarks of Duratech Industries International, Inc.

H-106 and ROCK-EZE are trademarks of Duratech Industries International, Inc.

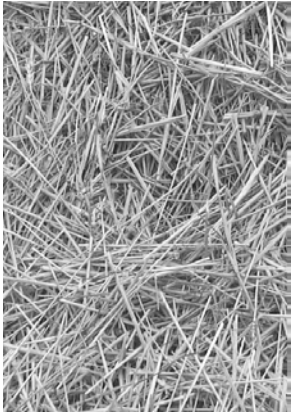

HAYBUSTER[®]
The Innovation Continues

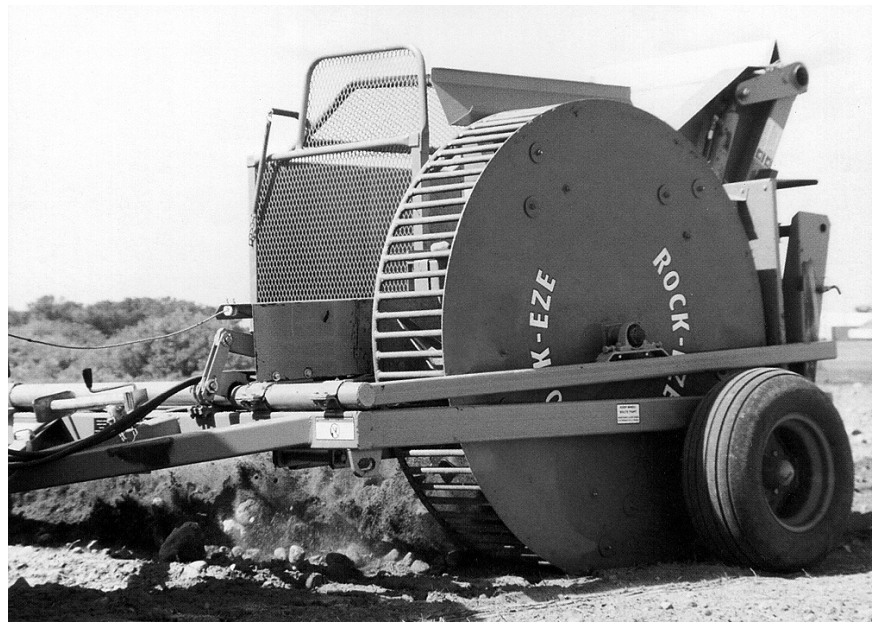
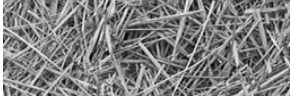

Foreword

All personnel must read and understand before operating unit

- Section 2, "Dealer Preparation," to verify that the machine has been prepared for use.
- Section 3, "Introduction," which explain normal operation of the machine.
- Foreword and Section 4, important safety information.
- Section 5.1, "Pre-Operation Inspection".

Appropriate use of the unit

This H-106 ROCK-EZE combination windrower and rock picker is designed to windrow fields while picking rocks with diameters from 2 to 15 inches.

Operator protection

As with all machinery, care needs to be taken by the operator in order to insure the safety of the operator and those in the surrounding area.

Operators and those observing the operation of the H-106 ROCK-EZE are required to wear head, eye, and ear protection. No loose clothing is allowed.

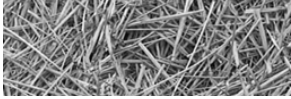

TABLE OF CONTENTS

Part 1: Operating Instructions	1
Section 1: How to use this manual	2
1.1 Manual organization	2
1.2 Dealer responsibilities	2
1.3 Operator responsibilities	3
Section 2: Dealer Preparation	4
2.1 Assembly	4
2.2 Adjustments	10
Section 3: Introduction	11
3.1 Hydraulic Specifications	12
3.2 Optional Equipment	12
Section 4: Safety	13
4.1 Warning safety decals	13
4.2 Shielding	14
4.3 Personal equipment	14
4.4 Safety review	14
4.5 Towing/road transport	16
Section 5: Operation	17
5.1 Pre-operation inspection	17
5.2 Normal shutdown procedure	18
5.3 ROCK-EZE hydraulic system	18
5.3.1 Using the 106 ROCK-EZE with triple hydraulic outlets	18
5.3.2 Using the 106 ROCK-EZE with dual hydraulic outlets	20
5.3.3 Using the 106 ROCK-EZE with a single hydraulic outlet	21
5.4 Operating Tips	22
5.5 Storage	22
5.5.1 Preparing the machine for storage	22
5.4.1 Removing the machine from storage	23

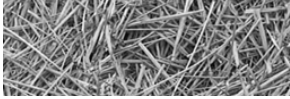

TABLE OF CONTENTS

Section 6: General maintenance 24

6.1 Lubrication 24

6.2 Axle, wheels, tires 27

6.3 General appearance 27

Appendix A: Warranty 28

Appendix B: General Specifications 29

Appendix C: Required for operation 30

Part 2: Parts Reference 31

MAIN FRAME ASSEMBLY SERIAL NO. 841015 THRU 32

ROCK BOX ASSEMBLY SERIAL NO. 84935 THRU 36

ROCK WHEEL ASSEMBLY SERIAL NO. 841085 THRU 38

ROCK WHEEL ASSEMBLY SERIAL NO. 841085 THRU 40

WINDROWER HANGER SERIAL NO. 841085 THRU 42

HYDRAULICS SERIAL NO. 84935 THRU GI2849 44

HYDRAULICS SERIAL NO. HI2850 THRU 46

TIRES AND WHEELS 48

WINDROWER MOTOR 49

ROCK KICKER MOTOR 50

CYLINDERS SERIAL NO. 101 THRU 2094 51

CYLINDERS (RAM) SERIAL NO. 2095 UP 52

SELECTOR VALVE (OPTION) 53

SELECTOR VALVE (OPTION) 54

DRAG PLATE (OPTION) 56

DECALS 58

H-106 ROCK-EZE Documentation Comment Form 61

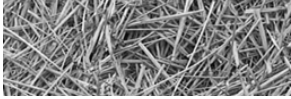

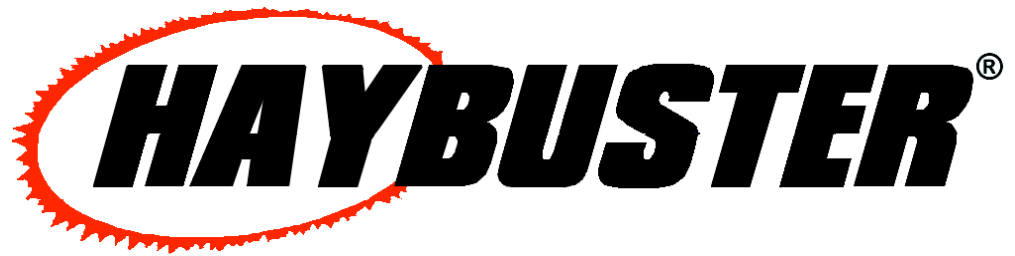
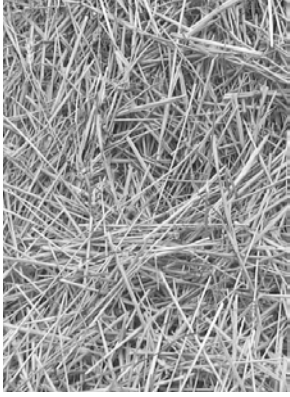

H-106TM

ROCK-EZETM

Serial Number 841085 & Up

**Part 1:
Operating Instructions**

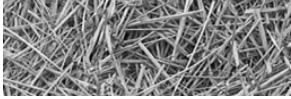

Part 1: Operating Instructions

Section 1: How to use this manual

1.1 Manual organization

This manual is organized into the following parts:

- Part 1: Operating instructions explain how to set up, use and maintain the ROCK-EZE.
- Part 2: Parts reference contains diagrams of each assembly, with the part number of each part. A key on the facing page contains a description of the part and the quantity used.

Note: When reference is made as to front, rear, right hand or left hand of this machine, the reference is always made from standing behind the rear end of the machine. Always use serial number and model number when referring to parts or problems.

MODEL ROCK-EZE **SERIAL NO.** _____

1.2 Dealer responsibilities

- Read Section 2, “Dealer Preparation,” and perform the tasks outlined. Also perform a pre-operation inspection as described in Section 5.1.
- Upon delivery of the unit to the customer, it is your responsibility to conduct a training session on the safe operation of the unit for the primary operator(s). You must also conduct a “walk-around” inspection of all safety instructional decals on the machine itself. Decals are illustrated in Part 2: Parts Reference.
- Complete and return the Warranty Registration Card. Receipt of this form is required to activate the warranty. Appendix A provides details of the warranty.

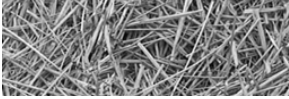

1.3 Operator responsibilities

- Operator is responsible for his safety.
- Operator is also responsible for safety of others near the machine.
- Review Section 2, "Dealer Preparation," to verify that the machine has been prepared for use.
- Thoroughly review sections 3 and 5, which explain normal operation of the machine, and section 6, which explain maintenance requirements.
- Note the important safety information in the Foreword and in Section 4, "Safety."
- Keep copies of all manuals in a readily -accessible location for future reference.

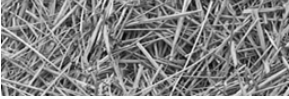

Section 2: Dealer Preparation

Machines shipped by truck have Windrower assembly removed. Main frame and rock wheel frame are secured by bolts and clamps. Windrower assembly should be bolted to frame and clamps removed. Two transport pins have been provided in upright rock wheel frame guides. Lock pins may be used to keep wheel in raised position for extended periods of time, or in case of hydraulic failure when transporting long distances. Be sure to remove any pins from transport position to prevent damage to machine while testing hydraulic controls.

2.1 Assembly

To assemble the ROCK-EZE for operation, follow the instructions on pages 10-16, steps 1-10.

STEP 1.

Begin assembly with machine on a level area. Hook machine to tractor drawbar. All assembly and adjustment must be done with drawbar height at 16 inches (plus or minus 1 inch) from ground level to top of drawbar

STEP 2.

Attach hoses to proper hydraulic outlets on tractor (illustrations pages 19, 20, and 21). For easy assembly of Windrower rotor (Step 3) raise rock to full height. Place safety block (provided with machine) on cylinder.

STEP 3.

Assemble windrower and bearings as shown on page 5. Slide end of Windrower rotor with bearing attached under machine towards rock wheel. Disconnect hose (A), on the facing page, at zerk fittings. Tighten elbow (B) into bearing with elbow pointing upward. Connect hose to elbow (B) slide rotor and bearing assembly into carrier bracket (D). Tighten bearing bolts securely. Reconnect hose (A) to zerk fitting. Install machine bushing and 7 Ga. washer on Windrower. See facing page. Bolt bearing shield (E) in place.

Linkage (H) adjust working height at inner end of Windrower. Clearance between rock wheel and carrier bracket plate (G) is made by adjustment (F) allowing rock wheel to turn without contacting plate.

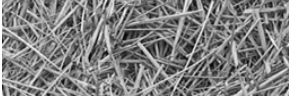

WINDROWER ROTOR INNER BEARING ASSEMBLY

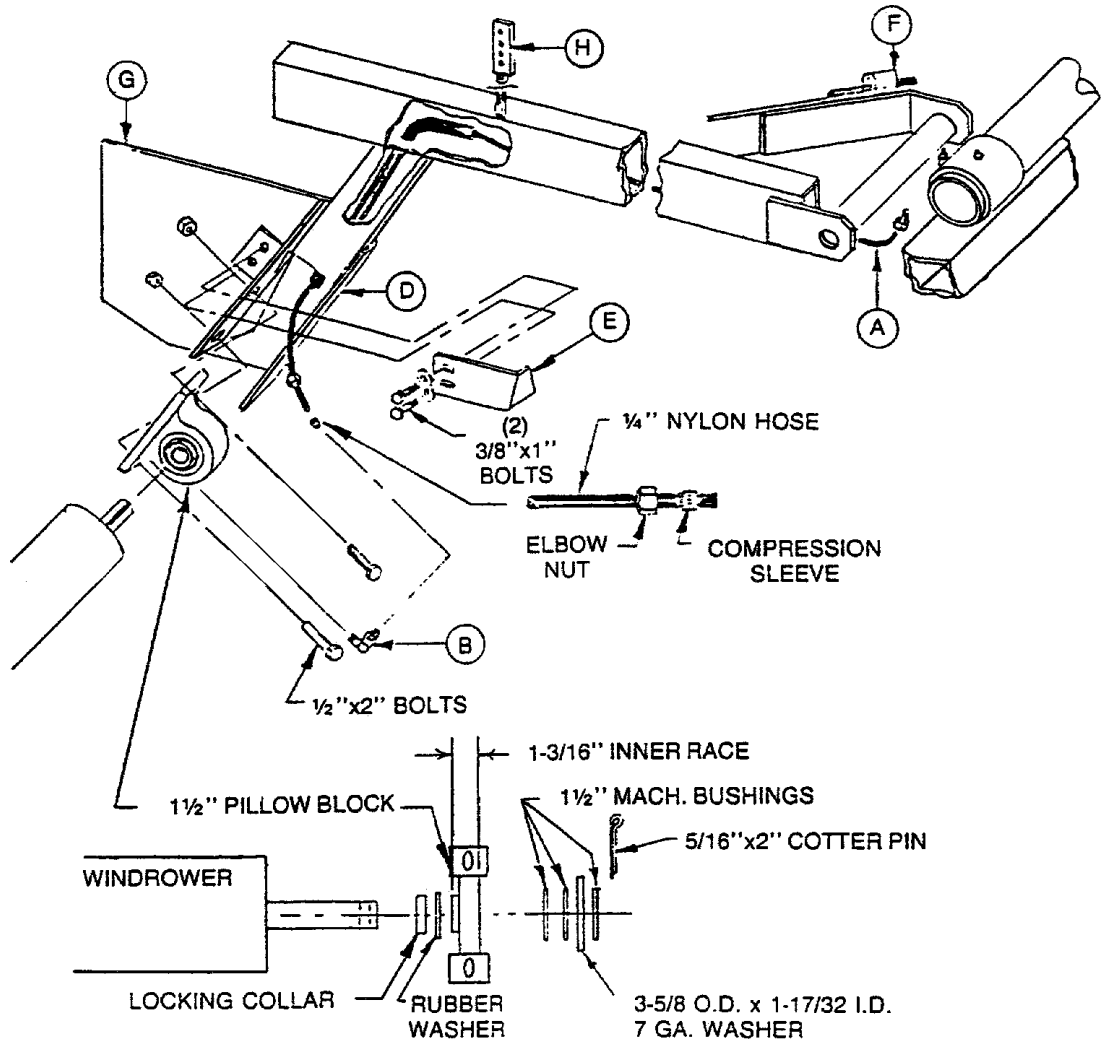

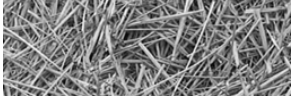

WINDROWER HANGER TUBE ASSEMBLY

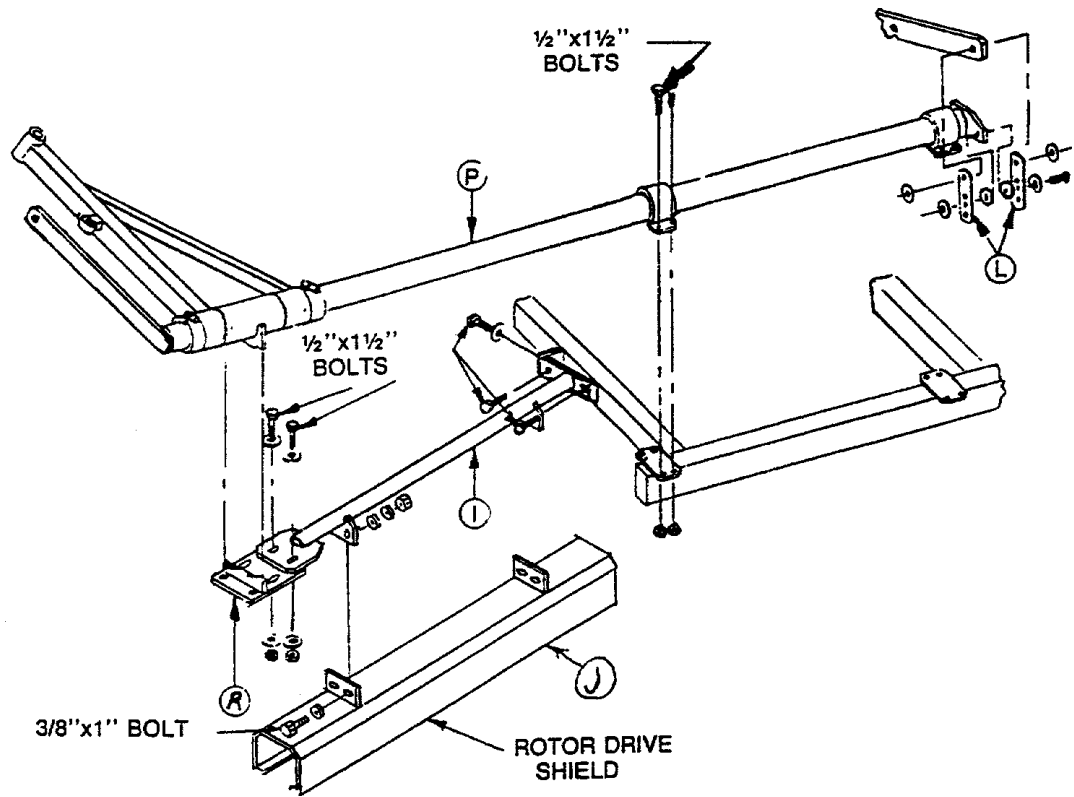

STEP 4.

Place Windrower hanger tube assembly on main frame mounts (illustrated above). Tighten down all bolts securely. Place hanger brace tube (I) on Windrower hanger (R). Opposite end bolts to main frame bracket. DO NOT tighten bolts at this time. Remove 3/4" pin and washer from linkage straps (L), connect to hanger tube using center hole.

Locate caster wheel with 1-1/4" machine bushings over shaft as illustrated on shown below and on page 8. Assemble caster wheel, machine bushings, and cotter key as shown below.

CASTER WHEEL ASSEMBLY

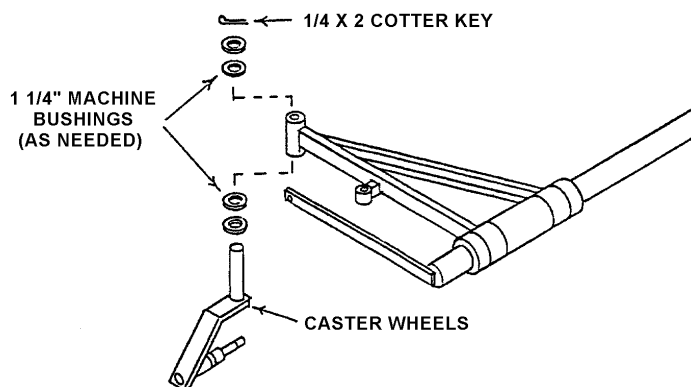

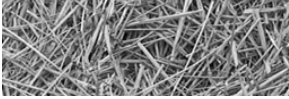

CHAIN CASE ASSEMBLY

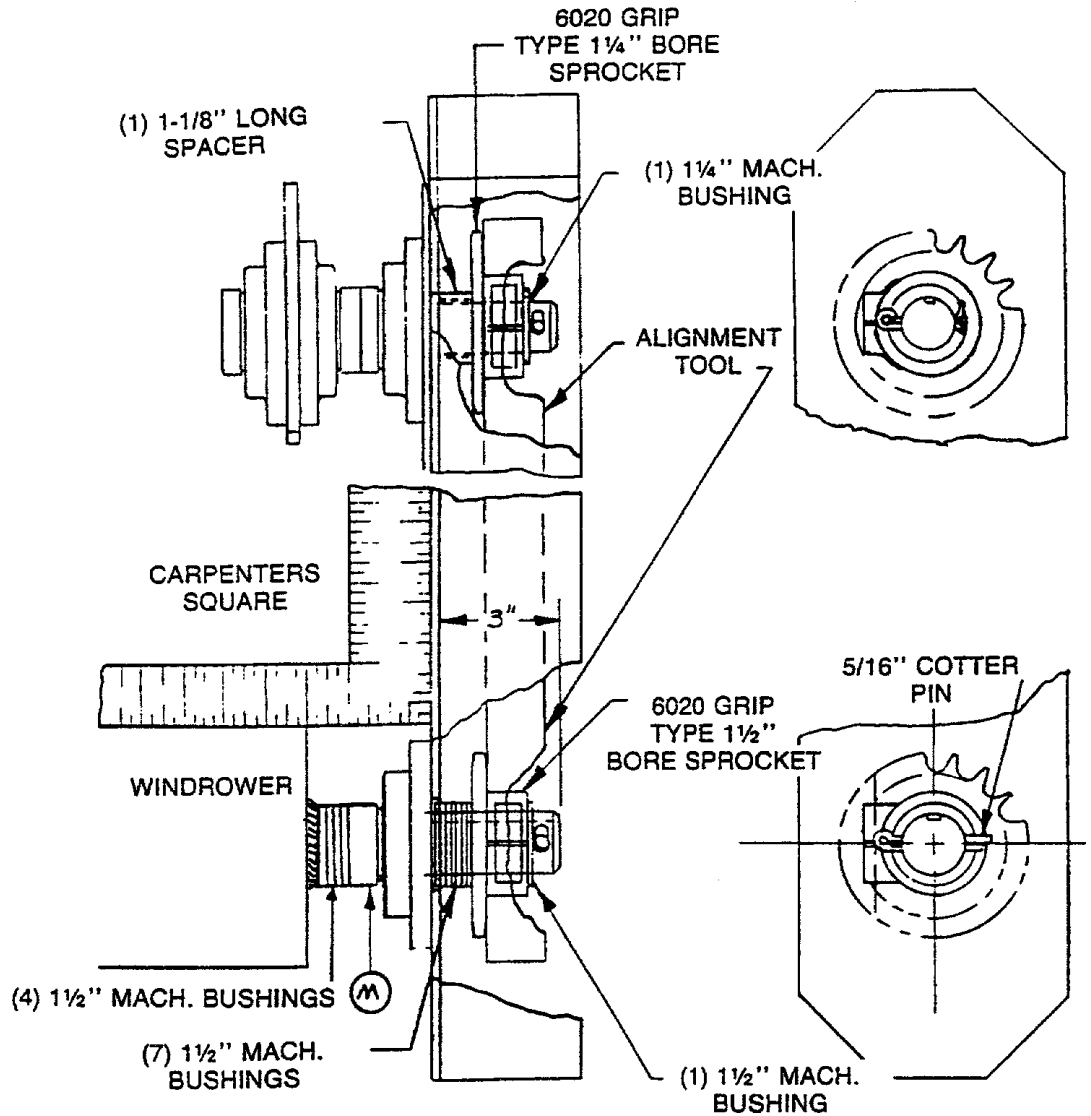

STEP 5.

Remove chain case cover. Slide (4) 1-1/2" machine bushings and lock collar (M), illustrated above, over Windrower rotor shaft (N). Slide 1-1/2" bearing (preassembled on case) over shaft (N), leaving 3" of shaft extending through case as shown in illustration. Secure bearing to shaft with lock collar and tighten Allen screw.

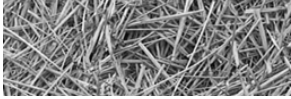

WINDROWER ROTOR DRIVE ASSEMBLY

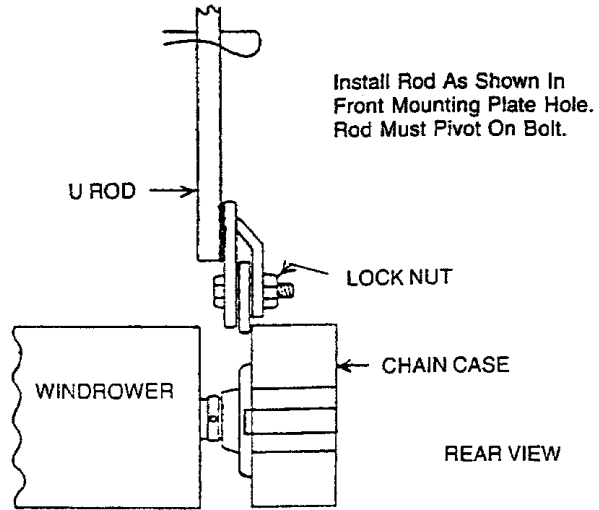
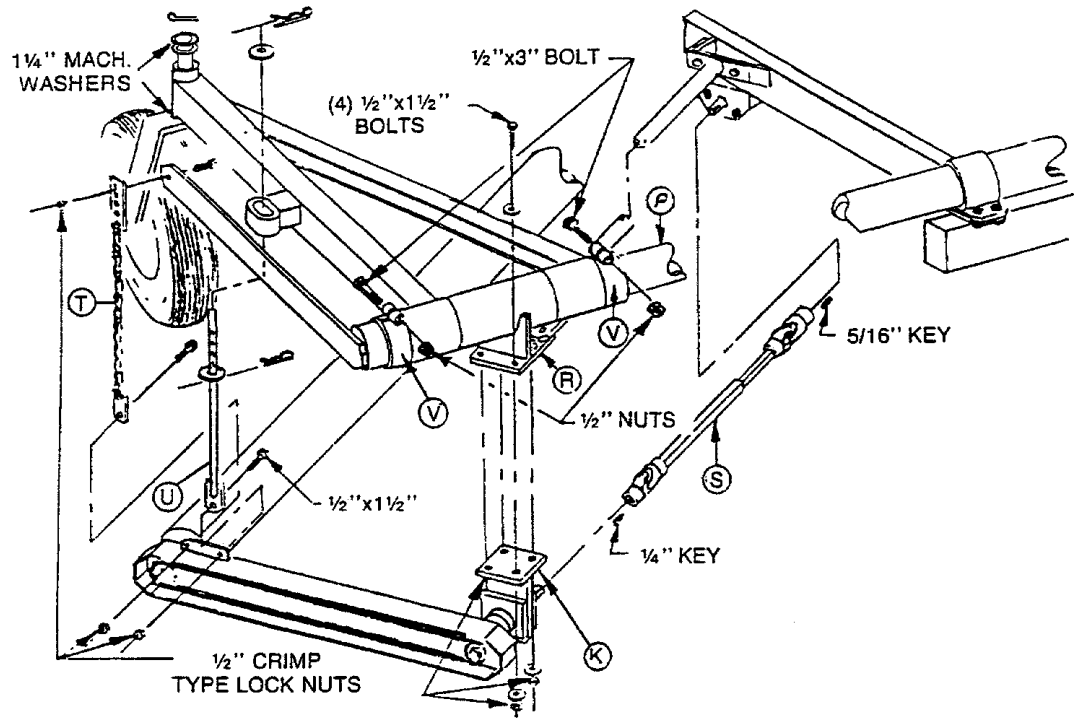

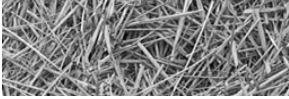

STEP 6.

Match (4) holes in bearing bracket (K), illustrated on facing page, to (4) holes in hanger support (R). DO NOT tighten bolts at this time. To get proper chain and sprocket alignment, Windrower rotor and drive chain case must be 90° to each other. This can be done by placing one edge of a carpenters square parallel to chain case and the other edge parallel to Windrower rotor illustrated on page 7. Proper angle can be obtained by sliding hanger ® in or out on hanger tube (P). Once proper alignment has been made, slide two pipe clamps (V) , illustrated on facing page, against caster wheel hinge support and tighten bolts.

STEP 7.

Locate 20 tooth sprocket, 3/8" square key, machine bushings, and cotter pin as illustrated on Page 7. Tighten two (2) Allen screws in sprocket hub, locking sprocket to shaft, and locking square key in key slot. Check sprocket alignment by placing aligning tool (found in chain case) along one edge of each sprocket as illustrated on Page 7. Due to oversize holes in hanger ® illustrated on the facing page, and bearing bracket (K) alignment of 20 tooth sprocket can be made by rotating these brackets slightly. Tighten all bolts in hanger and support brackets. Sprocket and chain alignment are important: recheck alignment before installing chain.

STEP 8.

Loosen (4) four nuts holding flange bearing and adjuster to chain case. Install chain. Adjust to proper tension (no sag between sprockets). Tighten bearing and adjuster nuts. Install chain case cover, being careful not to over tighten the center bolt causing cover to bend.

Remove plastic plug and fill approximately 1" below bottom of plug hole, use 90 weight oil. Install plug. Drive chain tension can also be checked through plug hole.

STEP 9.

Locate tumbling shaft (S), illustrated on the facing page. Install end with 5/16" key slot on hydraulic motor. Tighten Allen screws securely. Mount shield (J) on brace tube (1) Page 6. Tighten bolts securely.

Attach chain linkage (T) and adjusting rod (U) as illustrated on the facing page. Leave enough slack in bolts at hinge points so they can swivel when Windrower rotor is raised and lowered. Hole choice in upper end of chain linkage is used to get desired Windrower rotor height when in raised position.

STEP 10.

Place 1/4" hair pin in bottom hole of adjusting rod (U) under loop on caster wheel bracket. This carries wheel assembly when Windrower is in raised position. Top hair pin is placed in hole giving desired Windrower rotor height while in operation. Insert hair pins in direction shown on the facing page, to avoid lift arm contact.

Assembly of your DURATECH ROCK-EZE Model 106 is now complete. Recheck all bolts to make sure they are tight and grease all fittings. Also be sure all moving joints are free to allow rotor to float over uneven terrain.

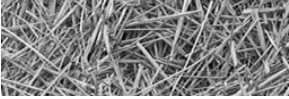

2.2 ADJUSTMENTS

Preliminary adjustments are made in the factory and during set up. Some adjusting may be necessary in field.

Machine was designed for a drawbar height of 16".

Depth of Windrower inner end nearest rock wheel is adjustable in 1" increments as shown at (H) on Page 5. of assembly instructions. Outer end is adjusted by changing upper hair pin in rod (U) Page 8, attached to chain drive case. Lower hair pin is designed to carry gauge wheel during transport.

Chain adjustment on outer end of Windrower is provided to level Windrower in raised position (T) Page 8.

Adjustments on Y bracket at front of main frame is described in step 3, page 4, and shown at (F) on Page 8, of assembly instructions.

There are three (3) adjustments on rock plate: (Not Shown).

1. One at rear of rock wheel which allows minimum clearance between rear of rock plate and ring on rock wheel.
2. One at front of rock box to allow clearance between front of rock plate and octagon hub of rock wheel.
3. One near lower portion of rock plate to relieve pressure against carrier bracket plate shown at (D) on Page 8, on assembly instructions.

The clearance of the kicker rotor stripper rubber is important. Bolt holes in rubber are slotted so it may be adjusted up or down where it bolts to the rock box. Rubber should be clear of square bars on rotor. Rubber may be turned top side down when a new edge is required.

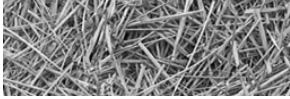
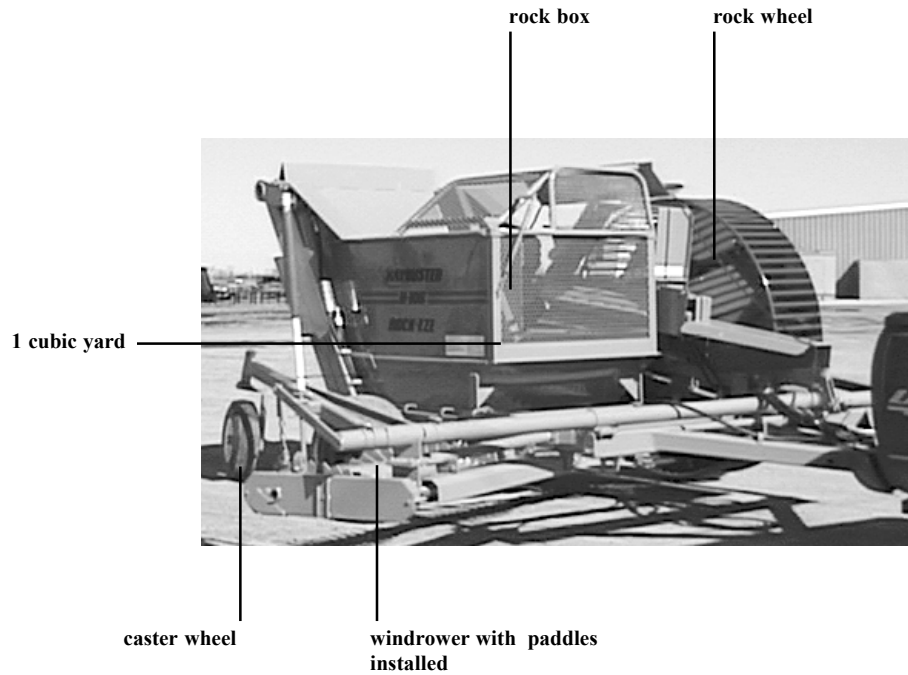

Figure 1.1
Introduction to ROCK-EZE
components



Section 3: Introduction

You have chosen a machine that will windrow and pick your rocks in one operation.

There are some important points to remember in the operation of your 106 ROCK-EZE.

1. The Tractor used to power your rockpicker should have an adequate hydraulic system. A minimum of 12 G.P.M., and 1500 P.S.I. is required at the outlets where hoses from rockpicker are plugged into tractor.

If the hydraulic system is not adequate, system will heat causing rotors to slow down and possibly stop. Some older tractors do not have coolers in their hydraulic system. Some have small oil reserves. Either case will allow fluid to heat rapidly.

When rotors operate properly, the rock box will fill nearly level from side to side. If box fills only on the side nearest the kicker rotor, R.P.M. should be checked with tachometer at rear of kicker rotor. Rotor should turn a minimum of 500 R.P.M. Any less will allow rocks to wedge in kicker rotor.

In cases when specifications are adequate, but rotors tend to operate too slow, tractors hydraulic system should be checked for G.P.M. and P.S.I., as systems tend to wear and not meet manufacturers specifications.

2. Conditions of terrain to be picked are important. Soil should be loose and free of trash. Terrain with ridges does not allow windrower to gather small stones.

This machine was not designed to dig rocks. In most cases, windrower rotor should be allowed to skim approximately 1" of loose topsoil.

Trash gathered in rock wheel does not allow small rocks to tumble free and the dirt to fall through bars.

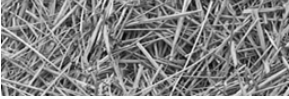

3.1 HYDRAULIC SPECIFICATIONS

Any tractor having an adequate system (minimum of 12 G.P.M. and 1500 P.S.I. at tractor outlets) may be used on this rockpicker. The ROCK-EZE comes standard with hoses to accommodate triple outlets from the tractor. Optional kits are available for tractor with single or double outlets.

3.2 OPTIONAL EQUIPMENT

1. Kits for equipment with single or double hydraulic outlets.
2. Loose surface rocks may be picked from level soil which is not tilled, such as pasture or stubble ground. Some rocks will roll out in front of the rock wheel. An optional drag plate is available to stop these rocks and direct them into the wheel.

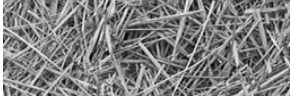

Section 4: Safety

The safety of the operator is of great importance to DuraTech. We have provided decals, shield and other safety features to aid you in using your machine safely. In addition, we ask you to be a careful operator who will properly use and service your DuraTech equipment.

WARNING: FAILURE TO COMPLY WITH SAFETY INSTRUCTIONS THAT FOLLOW WITHIN THIS MANUAL COULD RESULT IN SEVERE PERSONAL INJURY OR DEATH. BEFORE ATTEMPTING TO OPERATE THIS MACHINE, CAREFULLY READ ALL INSTRUCTIONS CONTAINED WITHIN THIS MANUAL. ALSO READ THE INSTRUCTION MANUAL PROVIDED WITH YOUR TRACTOR.

THIS MACHINE IS NOT TO BE USED FOR ANY PURPOSE OTHER THAN THAT FOR WHICH IT IS INTENDED AS EXPLAINED IN THE OPERATOR'S MANUAL, ADVERTISING LITERATURE OR OTHER DURATECH WRITTEN MATERIAL PERTAINING TO THE 106 ROCK-EZE.

4.1 Warning safety decals

DuraTech uses industry accepted ANSI standards in labeling its products for safety and operational characteristics. Red and white **DANGER** signs indicate that you **WILL** be severely injured if the recommendations on the danger sign are not followed. Orange **WARNING** decals indicate a potentially hazardous situation, which if not avoided, may result in death or serious injury. Yellow **CAUTION** decals indicate a potentially hazardous situation, which if not avoided, may result in a minor or moderate injury. In addition, black on white **ATTENTION** decals indicate non-safety related operational characteristics and procedures for the machine.

Decals are illustrated in **Part 2: Parts Reference**.

The safety decals located on your machine contain important and useful information that will help you operate your equipment safely.

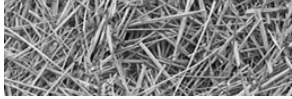

To assure that all decals remain in place and in good condition, follow the instructions below:

- Keep decals clean. Use soap and water - not mineral spirits, adhesive cleaners and other similar cleaners that will damage the decal.
- Replace all damaged or missing decals. When attaching decals, surface temperature of the machine must be at least 40° F (5° C). The surface must be also be clean and dry.
- When replacing a machine component to which a decal is attached, be sure to also replace the decal.
- Replacement decals can be purchased from your DuraTech dealer.

4.2 Shielding

Shields are installed for your protection. Keep them in place, and replace damaged shields.

4.3 Personal equipment

Operators of this machine are encouraged to wear head, eye, and ear protection. Loose clothing is discouraged.

4.4 Safety review

BEFORE OPERATING

- Read and follow all instructions contained in:
 - A. This 106 ROCK-EZE Operator's Manual.
 - B. Tractor operator's manual.
 - C. Decals placed on the ROCK-EZE and Tractor.

NOTE: Additional copies of the above mentioned materials can be obtained from your dealer.

- Allow only responsible, properly instructed individuals to operate your machine. Carefully supervise inexperienced operators.
- Use a tractor which meets the tractor requirements contained within this manual. **See REQUIRED FOR OPERATION: page 30.**
- Make sure the machine is in good operating condition and that all protective shields are in place and in proper working order. Replace damaged shields before operating.

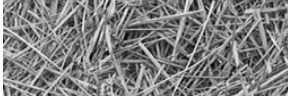

- Make no modifications to this equipment unless specifically requested or recommended by DuraTech.
- Tighten or replace any loose or cracked bolts, chains, hoses or connections.
- Check overhead for electrical power lines or other obstructions and be certain there is adequate clearance before raising hopper.

DURING OPERATION

Enforce the following safety precautions and others contained in this manual to prevent serious personal injury.

- Never leave the tractor controls unattended while the ROCK-EZE is operating.
- Always make sure the area behind the ROCK-EZE is clear before raising or lowering the bucket.
- Exercise extreme caution when operating the ROCK-EZE on steep slopes or grades.
- Be sure all spectators are clear of the area where ROCK-EZE is in operation.
- Be sure that the tractor operator is the only person riding the tractor. Allow no one to ride the ROCK-EZE at any time.
- Never work around or under the hopper when the hopper is lifted unless the safety stops are installed on both lift cylinders.
- Watch out for and avoid any object that might interfere with the proper operation on the machine.
- Keep hands, feet and clothing away from power driven parts.

WHEN PERFORMING SERVICE & MAINTENANCE

CAUTION: Before performing any maintenance or adjustments make sure machine is NOT running. If for any reason arc welding is to be done, always ground rotor to frame of machine to prevent arcing on bearings.

- Before working on or near ROCK-EZE for any reason, including servicing, inspecting or unclogging machine:
- If any service work is to be done on the ROCK-EZE while in the raised position, be sure to install hold up lock on cylinders or use a safety chain between movable frame and main frame to prevent dropping in case of hydraulic failure.

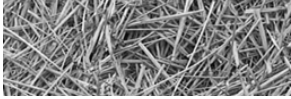

- Relieve all pressure in the hydraulic system before disconnecting the lines or performing other work on the system (bucket must be down). Make sure all connections are tight and the hoses and lines are in good condition before applying pressure to the systems.

CAUTION: Hydraulic fluid escaping under pressure can be invisible and have enough force to penetrate the skin. When searching for a suspected leak, use a piece of wood or cardboard rather than your hands. If injured, seek medical attention immediately to prevent serious infection or reaction.

- When replacing any part on your ROCK-EZE, be sure to use only DuraTech authorized parts.

4.5 Towing/road transport

- Use good judgment and drive slowly over rough or uneven terrain.
- Be sure tractor brakes are properly adjusted and foot pedals are locked together.
- The towing vehicle must be of equal or of greater weight than the ROCK-EZE and any load in hopper to assure adequate braking and steering control.
- Check your state laws regarding the use of lights, slow moving vehicle signs, safety chain and other possible requirements.

WARNING: FAILURE TO COMPLY WITH ANY OF THE PRECEDING SAFETY INSTRUCTIONS OR THOSE THAT FOLLOW WITHIN THIS MANUAL MAY RESULT IN SEVERE INJURY OR DEATH.

THIS ROCK-EZE IS NOT TO BE USED FOR ANY PURPOSE OTHER THAN THAT FOR WHICH IT'S INTENDED AS EXPLAINED IN THE OPERATOR'S MANUAL, ADVERTISING MATERIALS AND OTHER PERTINENT WRITTEN MATERIAL PREPARED BY DURATECH.

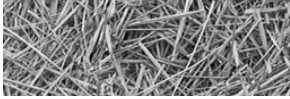

Section 5: Operation

To insure long life and economical operation, we highly recommend the operator of the ROCK-EZE be thoroughly instructed in the maintenance and operation of the machine.

There is no substitute for a sound preventative maintenance program and a well trained operator.

Prior to starting the engine of the tractor, we recommend the operator make a visual inspection of the unit. This can be done as the lubrication is being carried out. Any items that are worn, broken, missing or needing adjustment must be serviced accordingly before operating the ROCK-EZE.

5.1 Pre-operation inspection

WARNING: Before inspecting the machine, use the normal shutdown procedure in section in section 5.2 of this manual.

Check the following:

- Hydraulic components for leaks or damage.

WARNING: Hydraulic fluid escaping under pressure can be almost invisible and can have sufficient force to penetrate the skin. When searching for suspected leaks, use a piece of wood or cardboard rather than your hands. If injured, seek medical attention immediately to prevent serious infection or reaction.

- Lug Nuts for tightness.
- Condition of tire rims.
- Tires for proper air pressure.
- Installation and condition of flails.
- Chains for proper tension, and condition.
- Installation of slow moving vehicle (SMV) sign if required.
- Condition of decals.
- Installation and condition of shields.
- Belts for proper tension, and condition.

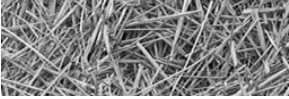

5.2 Normal shutdown procedure

WARNING: For your safety and the safety of others, you must use the following normal shutdown procedure before leaving the tractor controls unattended for any reason, including servicing, cleaning, or inspecting the ROCK-EZE. A variation of the following procedure may be used if so instructed within this manual or your tractor manual or if an extreme emergency requires it.

To shutdown the machine, perform the following steps:

1. Disengage PTO.
2. Lower machine to ground level or lock in raised position.
3. Place transmission in park or set park brake.
4. Relieve all pressure in the hydraulic system.
5. Shut off engine and remove key.
6. Wait for all movement to stop.

5.3 ROCK-EZE hydraulic system

5.3.1 Using the 106 ROCK-EZE with a tractor that has triple hydraulic outlets

To operate machine with triple outlets, Hoses A and B regulate rock wheel and windrower height. Hoses C and D are used when dumping the rock box. Try to use them only when you're ready to dump the box. Hoses E and F are hooked up to the windrower rotor and kicker rotor motors. Set the tractor controls so windrower rotor will kick the rocks ahead of the machine. See Illustration on facing page for more information.

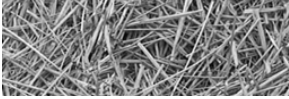

HI-LIFT HYDRAULIC SYSTEM USING TRIPLE OUTLETS FROM TRACTOR

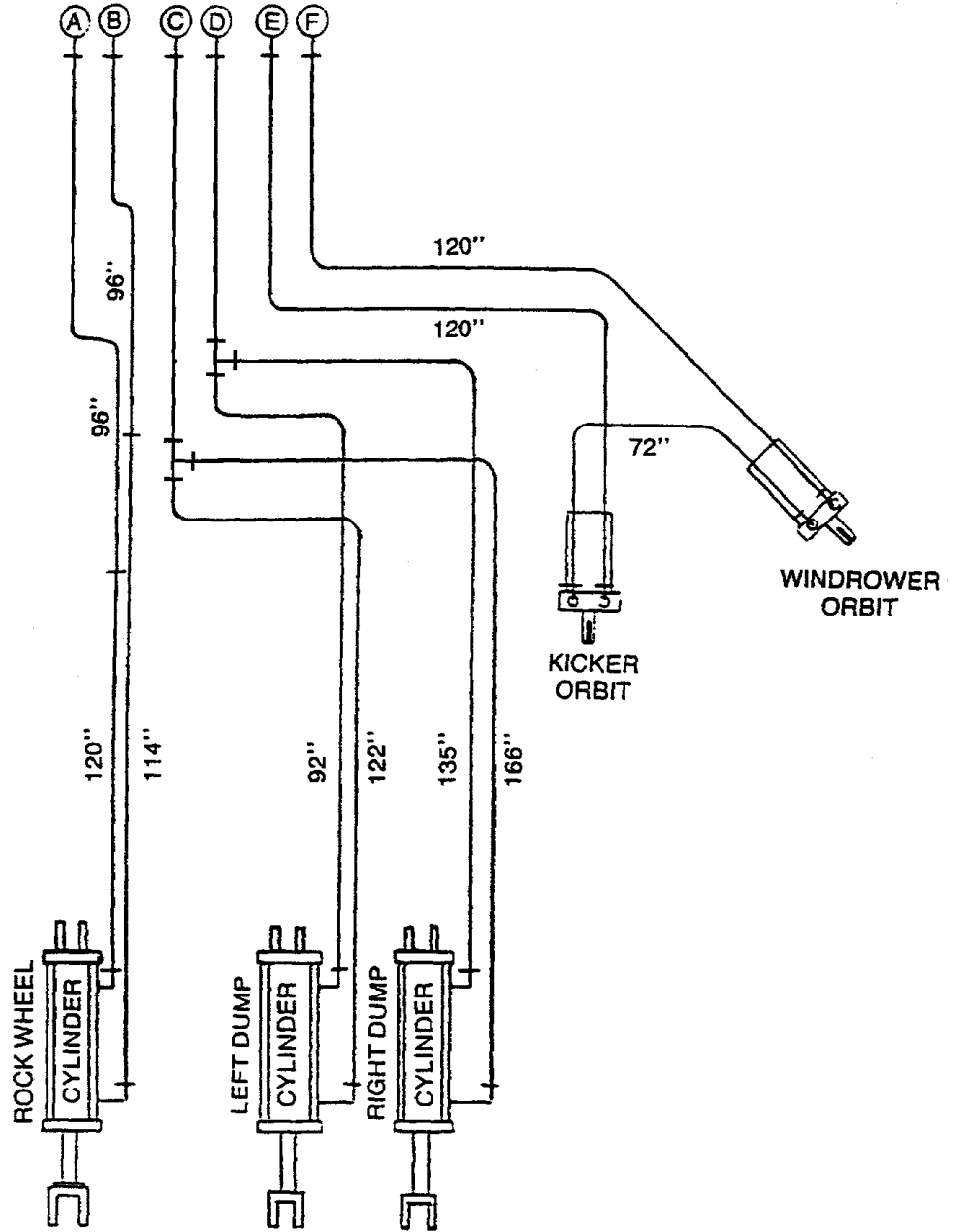

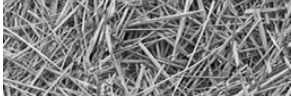

HI-LIFT HYDRAULIC SYSTEM USING DUAL OUTLETS FROM TRACTOR

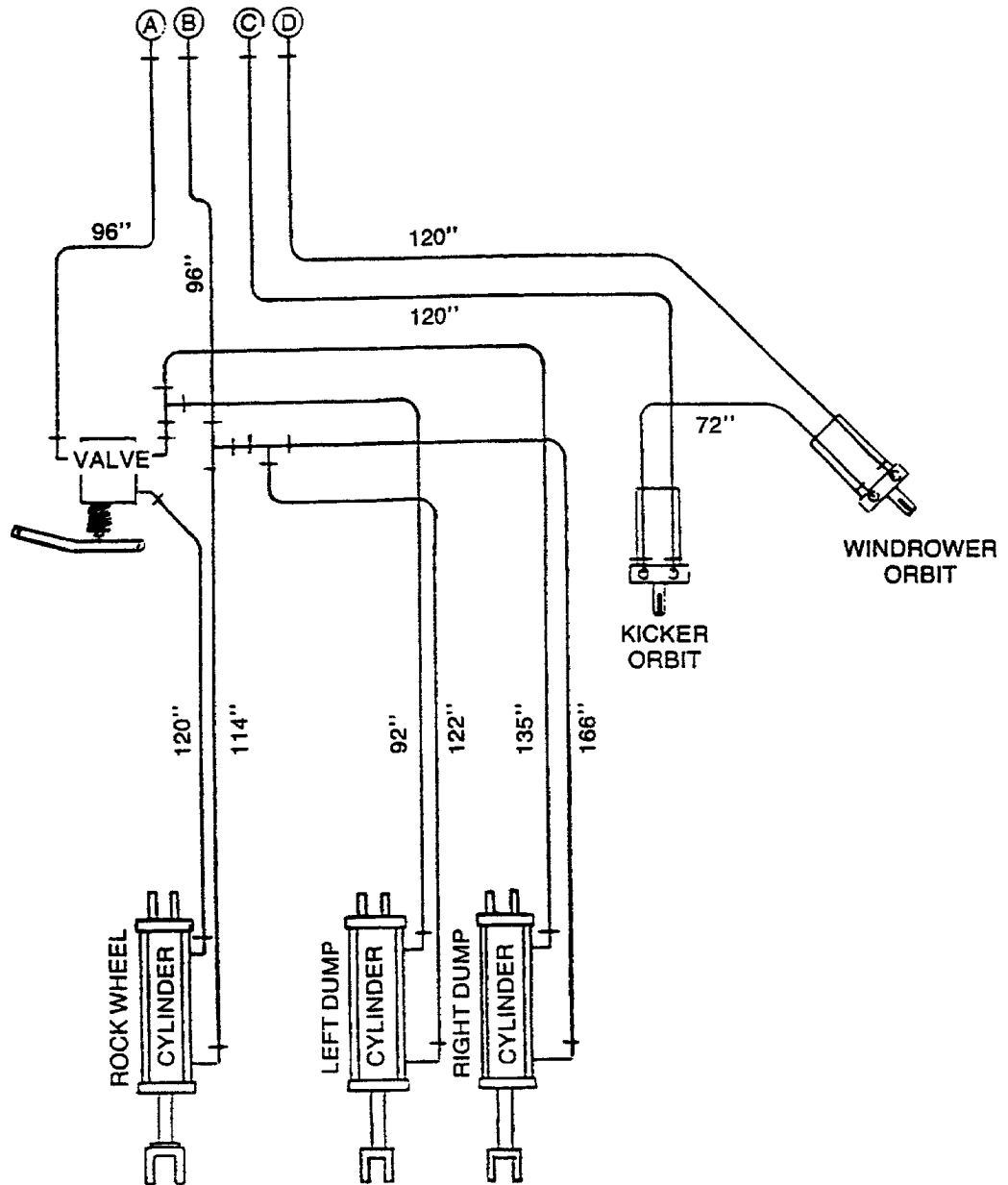

5.3.2 Using the 106 ROCK-EZE with a tractor that has dual hydraulic outlets

To operate machine with dual outlets, lock tractor control accommodating hoses C and D, illustrated above, in whichever position rotates Windrower rotor and kicker rotor correctly.

Hoses A and B are connected to the remaining outlets and control is operated as to raise or lower rock box. When rock box is filled, raise box for unloading by operating tractor control in same position as for raising wheel and pull rope attached to hydraulic valve. For lowering box, pull rope, and move tractor control to opposite position.

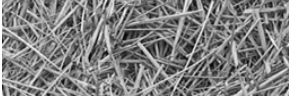

SINGLE HYDRAULIC HOOKUP

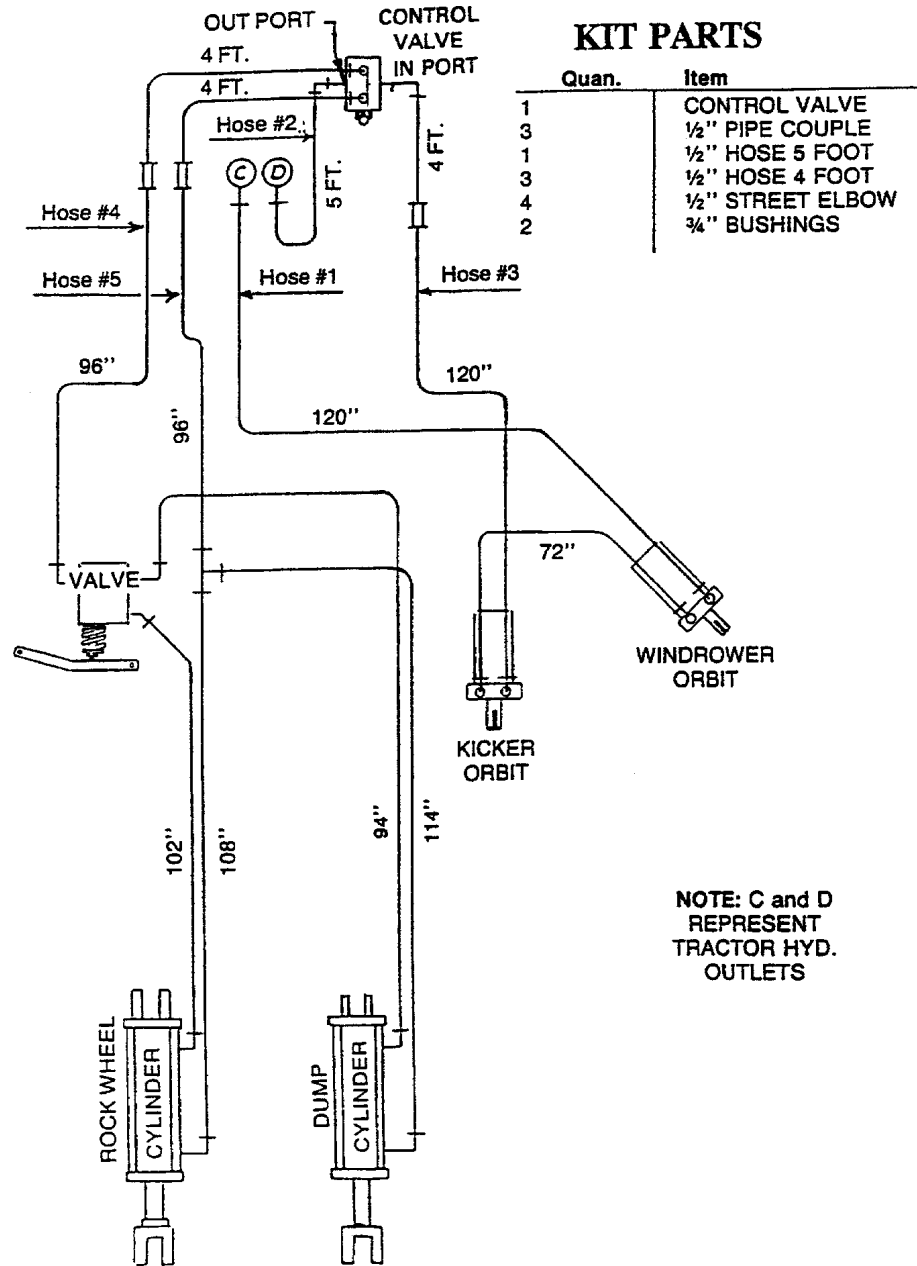

5.3.3 Using the 106 ROCK-EZE with a tractor that has a single hydraulic outlet

Attach (4) elbows and (2) bushings provided in kit to Hydraulic Valve. Mount Hydraulic Control Valve in suitable position on tractor. Connect hose No. 1 to tractor hydraulic outlet. Using 1/2" x 5' hose provided in kit, connect one end to remaining hydraulic outlet on tractor and other end to out port on Hydraulic Control Valve. Using the (3) 1/2" x 4' hoses and (3) straight couplings provided, connect to hoses NO. 3, 4, and 5. Connect No. 3 hose to in port on control valve. Connect No. 4 and No. 5 hoses to pressure ports on control valve. See illustration above.

When machine is operated from single outlet, the (2) rotors will rotate while raising or lowering rock box.

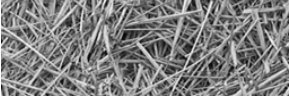

5.4 Operating Tips

- After machine is completely assembled as per assembly instructions, machine should be hooked to tractor drawbar. Jack should be removed from its mount and placed on second mount provided on top of main frame. This allows for shorter turning radius.
- When lowering Windrower and rock wheel, hold control until cylinder has completely contracted. This will allow wheel to float over uneven terrain.
- When in operation, it is possible for a rock to lodge between rock wheel and rock plate. If this occurs, it can usually be corrected by putting tractor in reverse and backing machine up a few feet.
- Over filling the rock box may cause the following problems:
 1. Rocks may lodge in kicker rotor. This may be corrected by reversing hydraulic control on the tractor causing rotor to reverse and free the rock.
 2. Rocks falling out near the kicker roller when unloading. The rocks may lodge between the rock wheel frame and main frame causing binding problems.

Note: The rock box is full when it is filled to 1 cubic yard. Figure 1.1 on page 11 illustrates the position at which the rock box is filled to approximately 1 cubic yard.

- Excessive ground speed does not allow Windrower rotor to gather stones in heavy rock areas. Also, rock box will fill toward front if rock wheel rotates too fast.
- Rotors should not be allowed to run in raised position when transporting machine long distances, such as to and from rock piles. This will prolong machine life and also hydraulic system.
- Most moving parts should be greased daily with the exception of the two Windrower rotor bearings which run in dirt constantly. These should be greased several times per day to prolong bearing life. Outer bearing has zerk on top of housing, Inner bearing is greased through tube extending to zerk on front of mainframe. Chain drive case should be checked periodically.

5.5 Storage

5.5.1 Preparing the machine for storage

This machine is designed to fold for ease of transportation and storage. The rack assembly folds inside of bale chamber.

WARNING: When preparing machine for storage, use normal shutdown procedure on page 18.

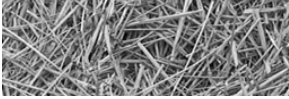

To prepare the ROCK-EZE for storage, perform the following steps:

1. Clean all mud, dirt, grease and other foreign material from the exterior of the machine. Wash the complete machine. If washing the ROCK-EZE with a high-pressure washer, keep the nozzle away from the sealed bearings. Repaint places where bare metal is exposed - this will inhibit rusting.
2. Place the jackstand in the down and in locked position. Block the rear axle up taking the weight off the tires, but do not deflate tires. If possible, store the machine in a dry, protected place. If it is necessary to store the machine outside, cover it with waterproof canvas, plastic, or other suitable protective material.
3. Coat exposed hydraulic cylinder rod with grease. Oil chains. Lubricate thoroughly according to lubrication instructions. Repack wheel bearings.
4. Check the machine for any worn or broken parts.
5. By ordering parts now, you will avoid delays when it is time to remove the machine from storage. When ordering parts always specify machine serial number and the part number of the replacement part. Part numbers can be found in the parts section of this manual.

5.4.1 Removing the machine from storage

To remove the ROCK-EZE from storage, perform the following steps:

1. Remove all protective coverings.
2. Remove blocking from under the machine
3. Lubricate machine in accordance with lubrication instructions found in this manual.
4. Follow pre-starting inspection instructions.

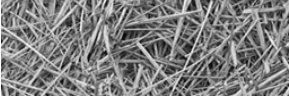

Section 6: General maintenance

NOTE: Before performing any service or maintenance on your ROCK-EZE, review the safety guidelines for performing service and maintenance in section 4.4 “Safety review” under the heading “**WHEN PERFORMING SERVICE AND MAINTENANCE**”.

6.1 Lubrication

LUBRICATION INSTRUCTIONS: The operator should make a check of all grease fittings in the unit before beginning to operate it so as to become familiar with their location and the correct service schedule.

Most moving parts should be greased daily with the exception of the two Windrower rotor bearings which run in dirt constantly. These should be greased several times per day to prolong bearing life. Outer bearing has zerk on top of housing, Inner bearing is greased through tube extending to zerk on front of mainframe. Chain drive case should be checked periodically

WARNING: Use normal shutdown procedure (Page 18) before lubricating machine.

Use only a high quality, multi-purpose grease when lubricating the unit. Make sure all fittings and the nozzle of the grease applicator are clean before applying the grease. If any grease fittings are missing, replace them immediately.

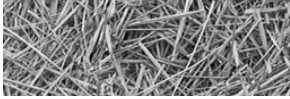
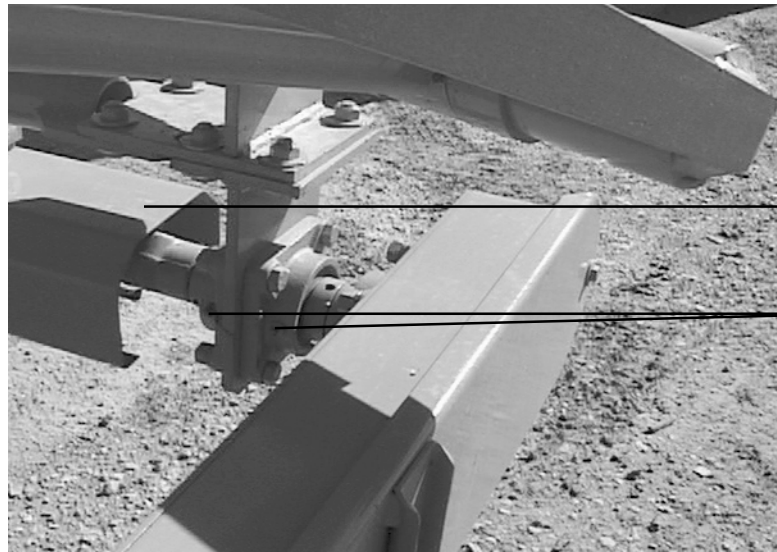

Figure 6.1
Windrower drive shaft zerks
and universal joints



check for universal joints
under this shield

windrower drive shaft
lubrication zerks

Figure 6.2
Chain case oil cap and outer
windrower rotor lubrication
zerk

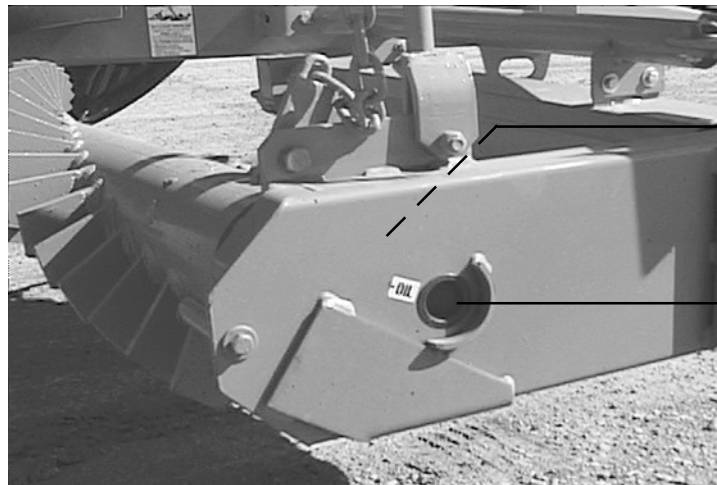

outer windrower rotor
lubrication zerk

chain case oil cap

Figure 6.3
Rock wheel bearing
lubrication zerk 1 of 2



lubrication zerk

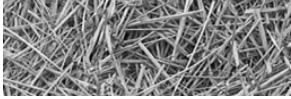
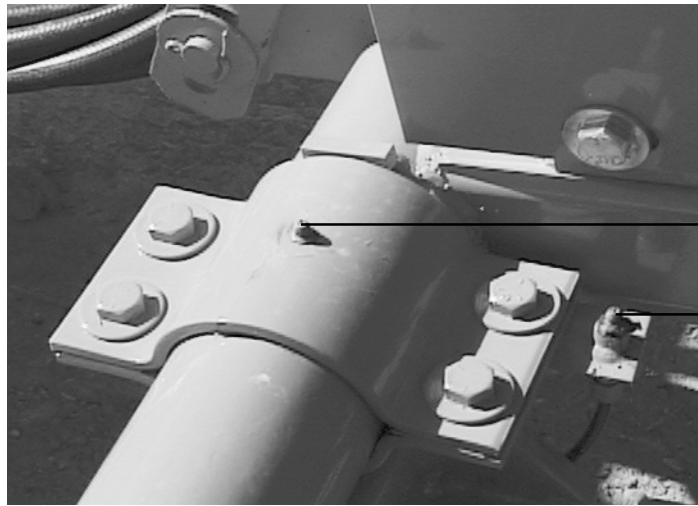

Figure 6.4
Rock wheel frame pivot and
inner windrower rotor
lubrication zerks



rock wheel frame pivot zerk 1
of 2

inner windrower rotor
lubrication zerk - lubricate
several times daily

Figure 6.5
Lubrication zerks for
the kicker rotor



kicker rotor zerks (2), 2nd
zerk is located near rear
bearing

lubrication zerk

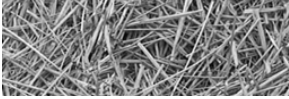

6.2 Axle, wheels, tires

Repack wheel bearings annually.

6.3 General appearance

Clean all mud, dirt, grease and other foreign material from the exterior of the machine. Cut all twine off from around the rotor and beater. Wash the entire machine. If washing the ROCK-EZE with a high pressure washer, keep the nozzle away from the sealed bearings. Repaint places where bare metal is exposed.

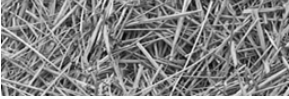

Appendix A: Warranty

DuraTech Industries International Inc. Warrants to the original purchaser for one year from purchase date that this product will be free from defects in material and workmanship when used as intended and under normal maintenance and operating conditions. This warranty is limited to the replacement of any defective part or parts returned to our factory in Jamestown ND, within thirty (30) days of failure.

This warranty shall become void if in DuraTech Industries International, Inc.'s, judgment the machine has been subject to misuse, negligence, alterations, damaged by accident or lack of required normal maintenance, or if the product has been used for a purpose for which it was not designed.

All claims for warranty must be made through the dealer which originally sold the product and all warranty adjustments must be made through same.

This warranty does not apply to tires or bearings or any other trade accessories not manufactured by DuraTech Industries International Inc. Buyer must rely solely on the existing warranty, if any, of these respective manufacturers.

DuraTech Industries International Inc., shall **not** be held liable for damages of any kind, direct, contingent, or consequential to property under this warranty. DuraTech Industries International Inc., cannot be held liable for any damages resulting from causes beyond its control. DuraTech Industries International Inc., shall not be held liable under this warranty for loss of crops, or rental costs or any expense or loss for labor or supplies.

DuraTech Industries International Inc., reserves the right to make changes in material and/or designs of this product at any time without notice.

This warranty is void if DuraTech Industries International Inc. does not receive a valid warranty registration card at its office in Jamestown, ND, within 10 days from date of original purchase.

All other warranties made with respect to this product, either expressed or implied, are hereby disclaimed by DuraTech Industries International Inc.

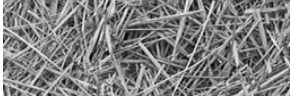

Appendix B: General Specifications

WEIGHT

Total 4,600 lbs.
 Tongue (in field mode, windrower and rock wheel up) 460 lbs.

SHIPPING DIMENSIONS (with Rock Windrower removed)

Truck Freight Width (with left-side tire, wheel, hub and spindle removed) 7' 10"
 Tow Width 9'
 Length 15' 5"
 Height 7' 7"

TRANSPORT & FIELD DIMENSIONS

Width 13'
 Length 15' 5"
 Height 7' 7"
 Dumping Height 14' 4"

CHASSIS FEATURES

Towing Arrangement Clevis Type Hitch
 Tires 2 (two) 11L x 16
 Wheels 10 x 16 - 8 Bolt, Drop Center
 Bearings Tapered Roller

ROCK PICKER MECHANISM

Windrower

Length 10'
 Finger Length 3"
 Outside Diameter 11"
 Drive Hydraulic Motor via. #50 Chain Drop Case
 Lift 1 (one) 2" x 8" Double Acting Hydraulic Cylinder
 that is shared with Rock Wheel Lift

ROCK WHEEL

Outside Diameter 6'
 Width 14-3/4"
 Bar Spacing 1-7/8"
 Number of Rock Paddles 5, Spring Cushioned
 Drive Ground Driven
 Lift 1 (one) 2" x 8" Double Acting Hydraulic Cylinder
 that is shared with Rock Wheel Lift

HOPPER

Dimensions 44" x 60"
 Capacity 1 (one) cu. yd of rocks
 Dump Height 84"
 Lift 2 (two) 3" x 24" Double Acting Hydraulic Cylinders

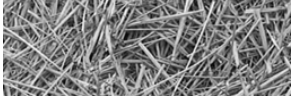

GENERAL SPECIFICATIONS CONTINUED

ROCK KICKER

Type Rotating, Fluted Roller
 Fluted Roller Dimensions 6-7/8" x 39"
 Fluted Roller Drive Hydraulic Motor

OPTIONAL EQUIPMENT

- **DRAG PLATE** - prevents rocks from being kicked into previously picked swath.
- **HOPPER DUMP VALVE KIT** - for use with tractors that have only 2 (two) hydraulic remote valve outlets, pull rope activated.

Appendix C: Required for operation

TRACTOR

Minimum PTO Horsepower Required 80
 Minimum Hydraulic Output 12 G.P.M. X 1500 P.S.I.
 Hydraulic Remote Controls 3 (three) double acting valves with quick coupler outlets*

* - The ROCK-EZE comes standard with hoses to accommodate triple outlets from the tractor. Optional kits are available for tractor with single or double outlets.

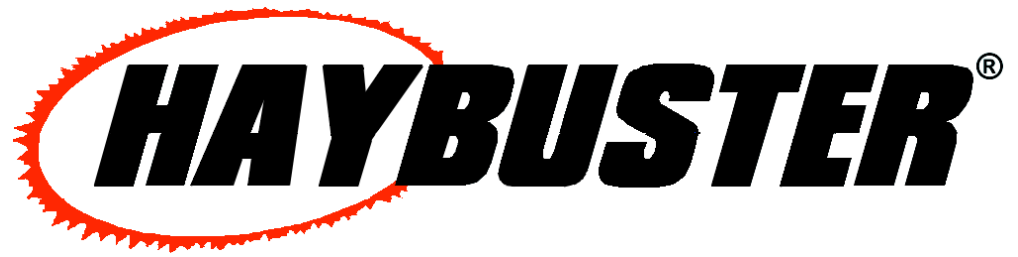
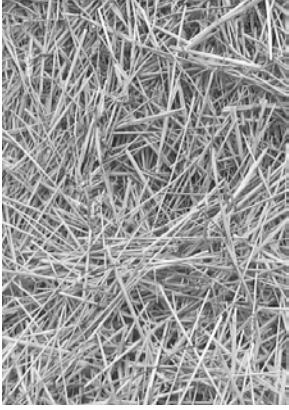

H-106TM

ROCK-EZETM

Serial Number 841085 & Up

Part 2:

Parts Reference

MAIN FRAME ASSEMBLY SERIAL NO. 841015 THRU

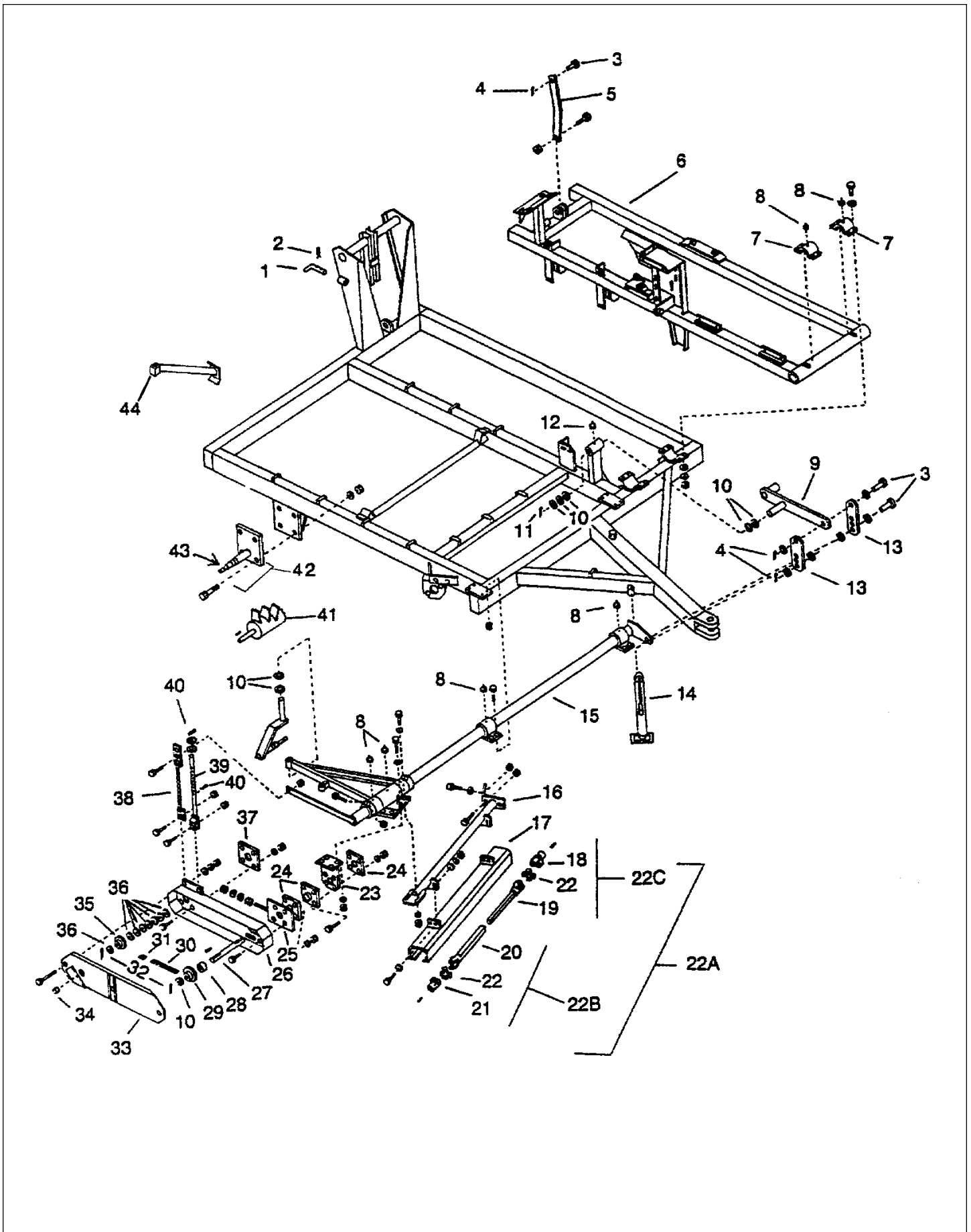

MAIN FRAME ASSEMBLY SERIAL NO. 841015 THRU

ITEM	PART NO.	QTY.	DESCRIPTION
1	6600102	2	Wheel Frame Stop Pin
2	4800107	2	1/8" Hair Pin
3	4800015	3	3/4" x 2" Clevis Pin
4	4800123	3	1/8" x 1-1/2" Cotter Pin
5	6600031	1	Wheel Lift Arm
6	6600101	1	Rock Wheel Frame
7	6600103	2	Wheel Frame Pivot Cap
8	3800094	7	Zerk 1/4" (Drive In)
9	6600072	1	Rocker Arm
10	5000007	10	Machine Washer 1-1/4" ID
11	4800157	1	3/16" x 2" Cotter Pin
12	3800041	1	Zerk 1/8" Pipe Thread
13	6600030	2	Lift Link
14	5800603	1	Jack
15	6600085	1	Carrier Arm
16	6600104	1	Support Bracket Brace
17	6600105	1	Power Shaft Shield
18	3600022	1	Power Shaft 1-1/4" Yoke\5/16" KW
19	3600072	2	Power Shaft Male Shaft and Yoke
20	3600071	1	Power Shaft Female Tube and Yoke
21	3600073	1	Power Shaft 1-1/4" Yoke\1/4" KW
22	3600074	2	Power Shaft Cross Bearing
22A	3600086	1	Power Shaft Complete H.D.
22B	3600069	1	Power Shaft Female Half H.D.
22C	3600070	1	Power Shaft Male Half H.D.
23	6600076	1	Drive Hanger
24	2000305	3	Cast Flange Bearing 4-Hole\1-1/4"Bore
25	6600078	1	Chain Tightener Plate
26	6600077	1	Chain Case
27	6600161	1	Shaft 1-1/4" x 11-1/2" Long
28	2000021	1	Bushing 1-1/4" ID \ 1-1/8" Long
29	1000001	1	Sprocket 6020\1-1/4" Bore\Hardened\Grip
29A	4800421	2	Set Screw, Allen. 5/16 x 3/8, NC
29B	4800440	1	Cap Screw, Allen, 5/16 x 1-1/4, NF
30	1100143	1	Chain\60 Pitch\81 Links, 1 Single Line w/ACL
31	1100062	1	#60 Connector Link
32	4800066	2	5/16" x 2" CotterPin
33	6600079	1	Chain Case Cover
33A	6600086	1	Oil Bath Gasket
34	6600080	1	Plug
35	1000106	1	Sprocket 6020, 1-1/2" w/Grip Type Hub
35A	4800143	2	Set Screw, Allen, 3/8 x 3/8, NC
35B	4800440	1	Cap Screw, Allen, 5/16 x 1-1/4, NF
36	5000008	8	Machine Washer 1-1/2" ID
37	2000303	1	4-Hole Flange Bearing 1-1/2" Bore
38	6600021	1	Chain Linkage
39	6600022	1	Adjustment Rod
40	4800042	2	1/4" Hair Pin
41	6600087	1	Windrower (Tooth Type)
41A	6600124		Windrower Replacement Tooth
42	6600137	2	Spindle w/Mount Plate
43	3000009	2	Spindle only
44	6600109	1	Stand High Lift Rear

MAIN FRAME ASSEMBLY SERIAL NO. 841015 THRU

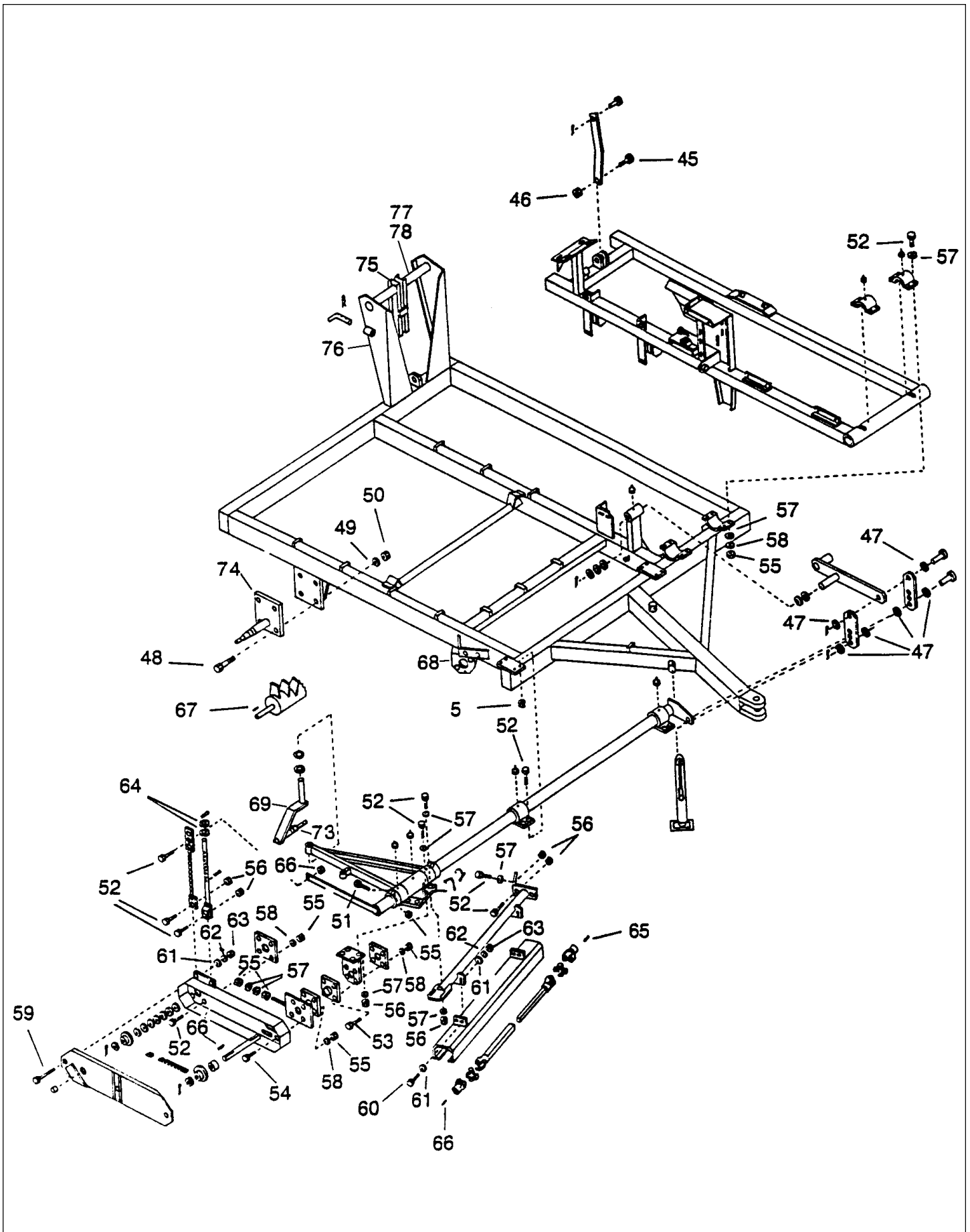

MAIN FRAME ASSEMBLY SERIAL NO. 841015 THRU

ITEM	PART NO.	QTY.	DESCRIPTION
45	4800134	1	3/4" X 3" Hex Bolt
46	4900013	1	3/4" Crimp Type Lock Nut
47	5000005	6	3/4" Flat Washer
48	4800010	8	5/8" x 2" Hex Bolt
49	5000003	8	5/8" Lock Washer
50	4900005	8	5/8" Hex Nut
51	4800068	2	1/2" x 3" Hex Bolt
52	4800082	32	1/2" x 1-1/2" Hex Bolt
53	4800070	4	1/2" x 2-1/2" Hex Bolt
54	4800201	4	1/2" x 1-3/4" Carriage Bolt
55	4900001	24	1/2" Hex Bolt
56	4900014	20	1/2" Crimp Type Lock Nut
57	5000004	30	1/2" Flat Washer
58	5000006	20	1/2" Lock Washer
59	4800202	3	3/8" x 5" Hex Bolt
60	4800003	4	3/8" x 1" Hex Bolt
61	5000001	14	3/8" Flat Washer
62	5000019	7	3/8" Lock Washer
63	4900002	7	3/8" Hex Nut
64	5000014	2	1" Flat Washer
65	6200004	1	5/16" x 1-1/2" Key
66	6200005	2	1/4" x 1-1/2" Key
67	6200007	1	3/8" x 1-1/2" Key
68	6600132	1	Orbit Motor Mount
69	6600126	1	Caster Wheel Spindle Frame
70	5000007	4	1-1/4" Machine Bushing
71	4800103	1	1/4" x 2" Cotter Pin
72	6600073	1	Support Bracket
73	3000023	1	6-3/4x1-1/4 Spindle ONLY
74	6600023	1	Gauge Wheel Spindle Assembly w/Hub and Wheel
75	6600191		Lift\Wheel\Arm
76	6600257		Wldmnt\Sub\Rckwhl_Lift\MF
77	D1002354		Tube\Lift\Rockwhl
78	D1002355		Pipe\Lift\Rockwhl
	6600179		BRKT\CASTLE\WHL

ROCK BOX ASSEMBLY SERIAL NO. 84935 THRU

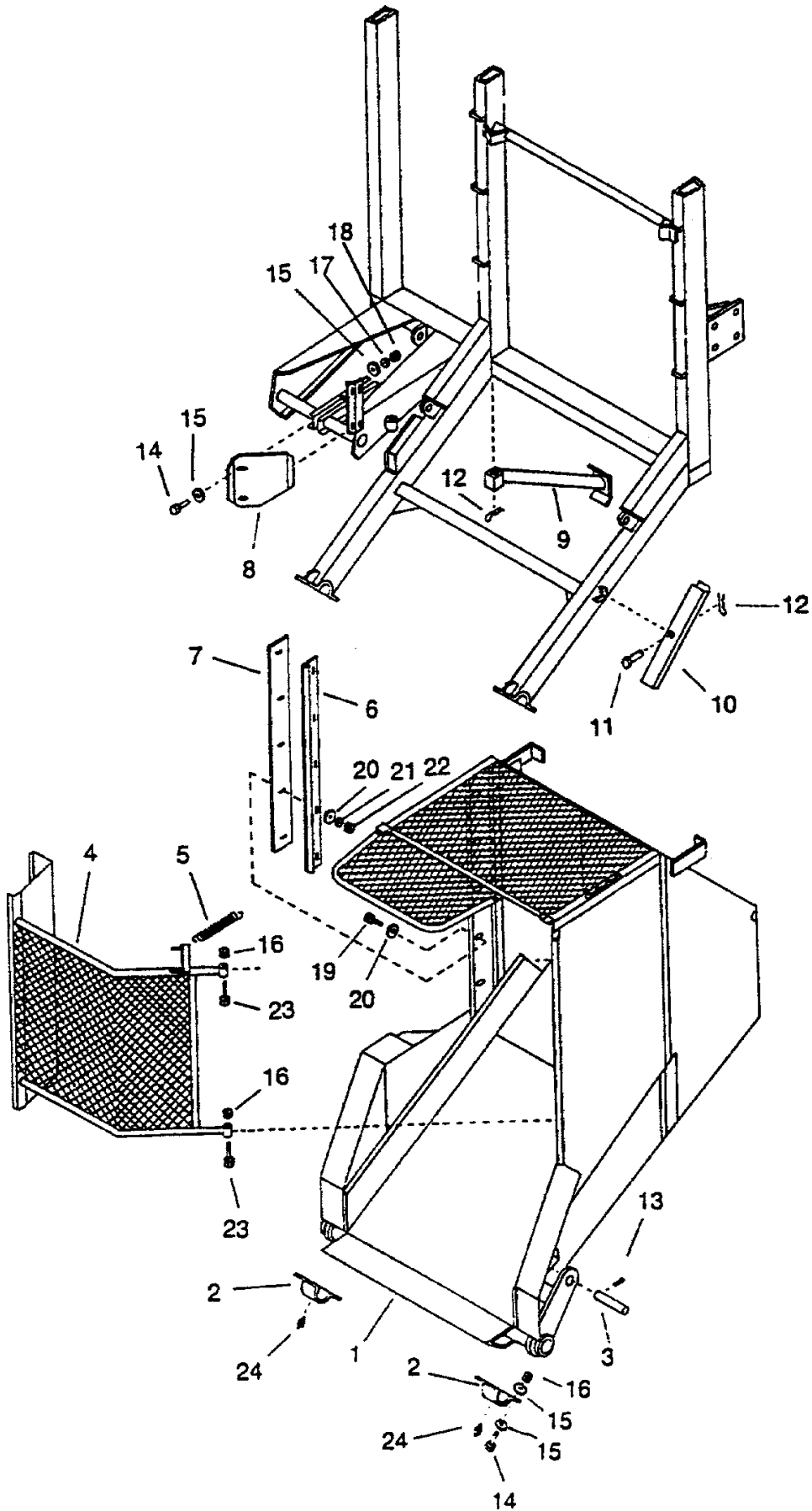

ROCK BOX ASSEMBLY SERIAL NO. 84935 THRU

ITEM	PART NO.	QTY.	DESCRIPTION
1	6600106	1	Bucket (High Lift)
2	6600075	2	Bucket Hinge Clamp
3	6600163	2	Cylinder Pin 1" x 6-1/2" SN 101-2094
3A	6600131	2	Cylinder Pin 1" x 7" SN 2095-
4	6600107	1	Fall-Out Shield
5	6100001	1	Pull Spring
6	6600051	1	Belting Plate
7	1700026	1	Belting 5" x44-1/2"
8	6600108	1	Rock Shield
9	6600109	1	Stand
10	6600083	2	Bucket Hold Up Safety Clamp
11	4800046	2	3/4" x 3" Clevis Pin
12	4800107	3	1/8" Hair Pin
13	4800103	2	1/4" x 2" Cotter Pin
14	4800082	10	1/2" x 1-1/2" Hex Bolt
15	5000004	20	1/2" Flat Washer
16	4900014	10	1/2" Top Lock Nut
17	5000006	10	1/2" Lock Washer
18	4900001	10	1/2" Hex Nut
19	4800034	5	3/8" x 1-1/2" Hex Bolt
20	5000001	10	3/8" Flat Washer
21	5000019	5	3/8" Lock Washer
22	4900002	5	3/8" Hex Nut
23	4800188	2	1/2" x 4" Hex Bolt
24	3800041	2	1/8" Zerk
	D1013046		Rock Box Bottom

ROCK WHEEL ASSEMBLY SERIAL NO. 841085 THRU

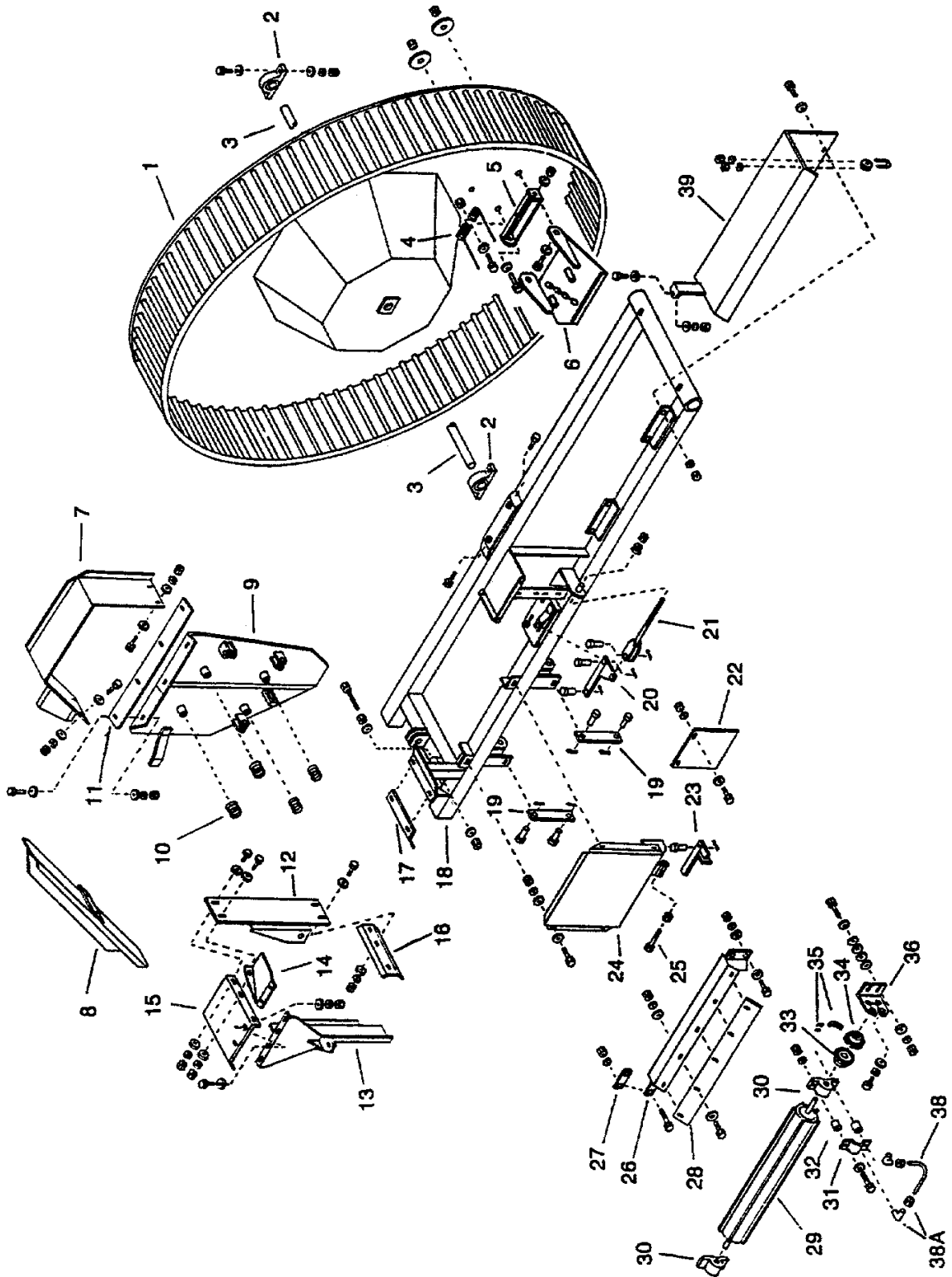

ROCK WHEEL ASSEMBLY SERIAL NO. 841085 THRU

ITEM	PART NO.	QTY.	DESCRIPTION
1	6600053	1	Rock Wheel
2	2000505	2	Bearing
3	6600160	1	Shaft 24 x 1-3/4
4	6100018	5	Paddle Spring
5	6600054	5	Paddle Hinge
6	6600055	5	Rock Paddle
7	6600111	1	Rock Shield (High Lift)
	6600056	1	Rock Shield (Low Lift) Not Shown
8	6600071	1	Unloading Shield (Low Lift Only)
9	6600070	1	Spring Loaded Plate
10	6100007	4	Spring\ Rock Plate
11	1700029	1	4 x 38-3/4\ 3-ply Belting
12	6600112	1	Left Cylinder Shield
13	6600113	1	Right Cylinder Shield
14	6600114	1	Upper Front Cylinder Shield
15	6600115	1	Upper Rear Cylinder Shield
16	6600116	1	Lower Cylinder Shield
17	6600057	1	Unloading Shield Bracket (Low Lift ONLY)
18	6600101	1	Rock Wheel Frame
19	6600009	2	Arm Spring Loaded Plate
20	6600058	1	Top Linkage Plate
21	6600060	1	Adjusting Bolt
22	6600059	1	Orbit Motor Shield
23	6600061	1	Bodom Linkage Plate
24	6600062	1	Spring Bracket
25	6600063	1	Adjusting Bolt
26	6600117	1	Hose Protector
27	6600118	1	Hose Protector Mounting Strap
28	1700027	1	Hose Protector Belting 5" x 39"
29	6600005	1	Kicker Roller
30	2000513	2	Bearing 1-1/4" Mallable
31	6600119	2	Bearing Strap
32	6600120	4	Bearing Strap Spacer
33	1000072	1	5014 Sprocket 1-1/4" Bore
33A	4800227	2	Set Screw, Allen, 5/16 x 5/16, NC
34	1000029	1	5014 Sprocket 1" Bore
34A	4800421	2	Set Screw, Allen, 5/16 x 3/8, NC
35	1100026	1	50 Pitch Chain Double 13 Links
35A	1100099	1	50 Pitch Double Connector Links
36	6600006	1	Orbit Motor Bracket
38	3700117	1	1/4" Hose 14-1/2"
38A	3800062	2	1/8" P.T. to 1/4" Tube 90 Degree Ell.
39	6600064	1	Front Rock Shield
	6200012		KEY\SQ\1/4X2

ROCK WHEEL ASSEMBLY SERIAL NO. 841085 THRU

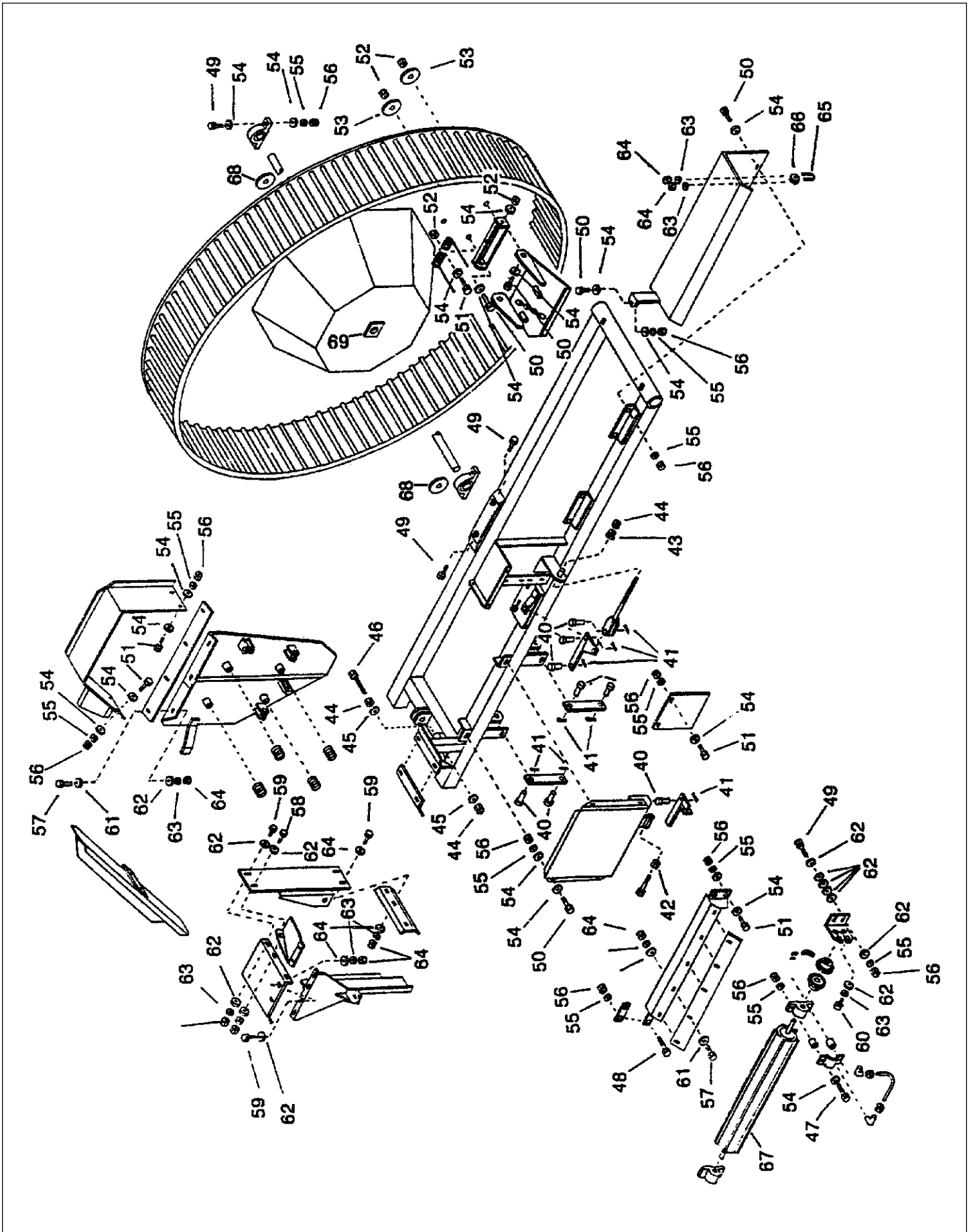

ROCK WHEEL ASSEMBLY SERIAL NO. 841085 THRU

ITEM	PART NO.	QTY.	DESCRIPTION
40	4800035	8	3/4" x 2" Clevis Pin
41	4800203	8	5/32" x 2" Cotter Pin
42	4900004	1	3/4" Hex Nut
43	4900058	1	5/8" Flange Nut
44	4900005	3	5/8" Hex Nut
45	5000002	2	5/8" Flat Washer
46	6600122	1	5/8" x 5-1/2" Adjusting Bolt
47	4800041	4	1/2" x 5" Hex Bolt
48	4800135	2	1/2" x 3-1/2" Hex Bolt
49	4800070	10	1/2" x 2-1/2" Hex Bolt
50	4800082	29	1/2" x 1-1/2" Hex Bolt
51	4800018	16	1/2" x 1-1/4" Hex Bolt
52	4900014	30	1/2" Locking Nut Crimp
53	6600123	10	1/2" ID x 3" OD Washer
54	5000004	40	1/2" Flat Washer
55	5000006	27	1/2" Lock Washer
56	4900001	27	1/2" Hex Nut
57	4800034	9	3/8" x 1-1/2" Hex Bolt
58	4800098	1	3/8" x 1-1/4" Hex Bolt
59	4800003	7	3/8" x 1" Hex Bolt
60	4800164	4	3/8" x 3/4" Hex Bolt
61	5000017	9	3/8" Fender Washer
62	5000001	59	3/8" Flat Washer
63	5000019	32	3/8" Lock Washer
64	4900002	32	3/8" Hex Nut
65	4800067	1	3/8" U-Bolt 2" ID
66	7500212	1	Rope Guide
67	6600148	5	Kicker Roller Bars
68	5000051	6	Wash\Mach\ 1-3/4" x 10 Gauge
69	6600127	2	Rock\Wheel\Hub\Weldment

WINDROWER HANGER SERIAL NO. 841085 THRU

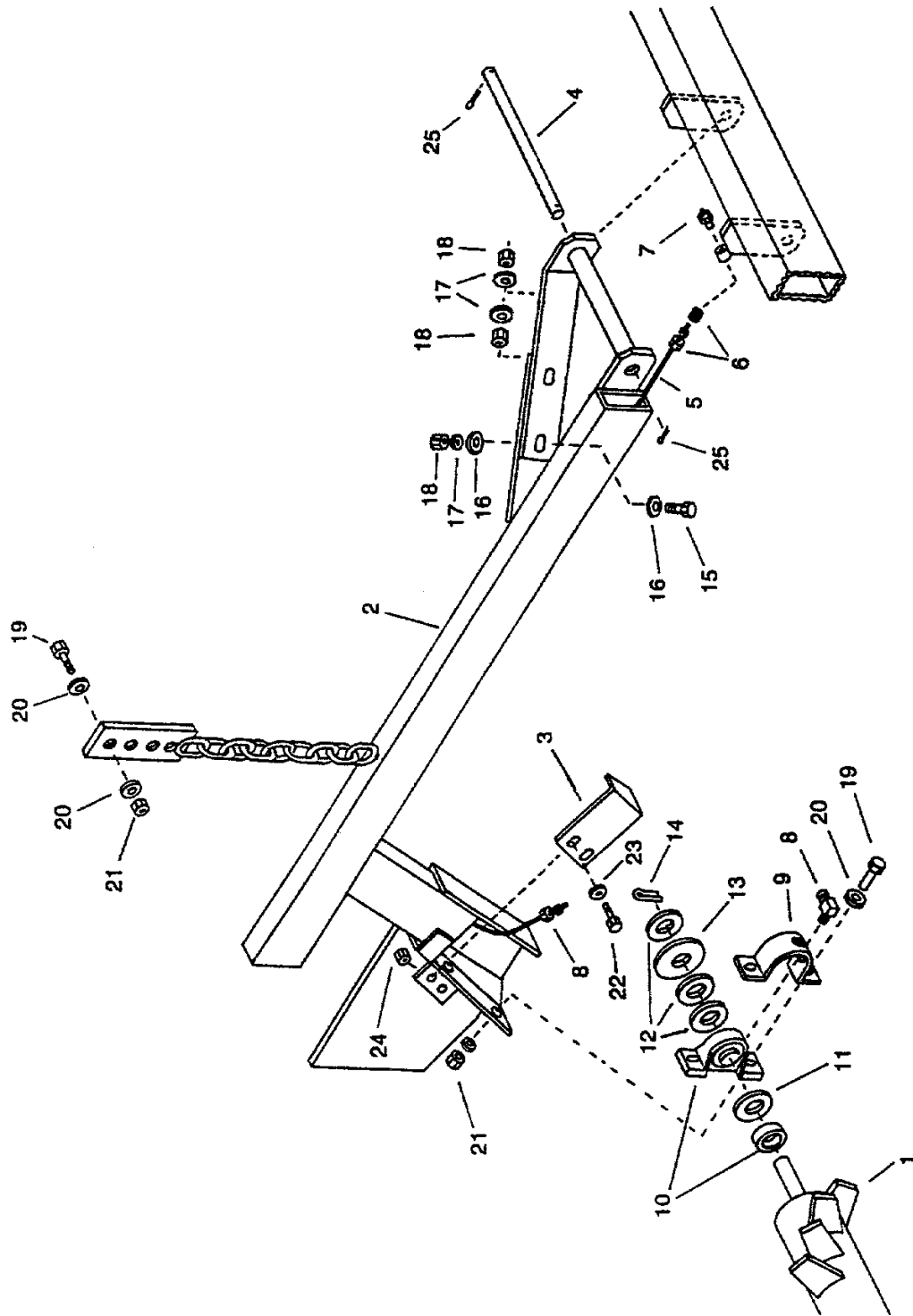

WINDROWER HANGER SERIAL NO. 841085 THRU

ITEM	PART NO.	QTY.	DESCRIPTION
1	6600087	1	Windrower
2	6600066	1	Windrower Hanger
3	6600026	1	Bearing Shield
4	4800028	1	Hinge Pin\1" x 14-1/2"
5	3700032	1	1/4" Hose 72"
6	3800095	1	1/8" Nipple and Coupling
7	3800041	1	1/8" Zerk (Straight)
8	3800062	1	1/8" PT to 1/4" Tube 90 Degree Ell.
9	6600036	1	Bearing Strap
10	2000511	1	Bearing with Collar
11	6600067	1	Rubber Shield
12	5000008	3	1-1/2" Machine Bushing
13	6600121	1	7 GA Washer 3-5/8: OD x 1-17/32" ID
14	4800066	1	5/16" x 2" Cotter Pin
15	4800010	2	5/8" x 2" Hex Bolt
16	5000002	4	5/8" Flat Washer
17	5000003	2	5/8" Lock Washer
18	4900005	4	5/8" Hex Nut
19	4800114	3	1/2" x 2" Hex Bolt
20	5000004	4	1/2" Flat Washer
21	4900014	3	1/2" Lock Nut Crimp Type
22	4800003	2	3/8" x 1" Hex Bolt
23	5000001	2	3/8" Flat Washer
24	4900023	2	3/8" Lock Nut
25	4800203	2	5/32" x 2" Cotter Pin
	6600226	opt	Kit\Conv\Winrower\Hardened
	6600135		Windrower Stub Shaft Drive
	6600136		Windrower Stub Shaft Idler
	6600204		Tooth\Windrower\Hardface
	7500215		Bearing Kit, includes #3, 8, 9, 10

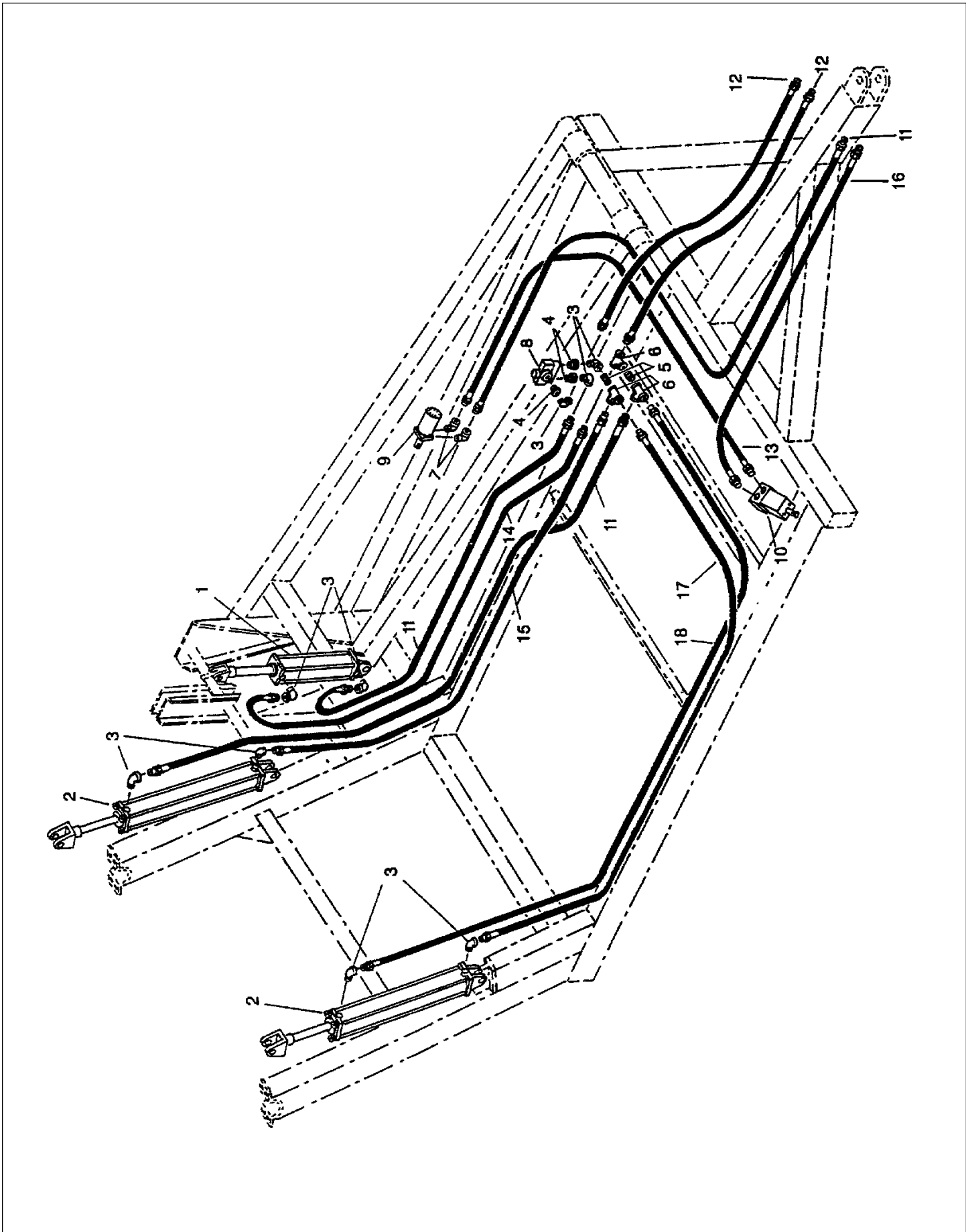

HYDRAULICS SERIAL NO 84935 THRU G12849

ITEM	PART NO.	QTY.	DESCRIPTION
1	4100073	1	2" x 8" Hyd. Cylinder (Ram)
1A	4100114	1	2-1/2" x 8" Hyd. Cylinder (Ram)
2	4100032	2	3" x 24" Hyd. Cylinder SN 101-2095
2A	4100085	2	3" x 24" Hyd. Cylinder SN 2095 (Ram)
3	3800008	9	90 Degree 1/2" St. Ell.
4	3800119	3	Fitting\1-1/16 MOR x 1/2 FP\ADPTR
5	3800045	2	1/2" x 2" Nipple
6	3800009	3	1/2" Tee
7	3800028	2	45 Degree 1/2" St. Ell.
8	4000115	1	Valve
9	3900006	1	203 Orbit Motor
10	3900007	1	2000 Orbit Motor, One Way Rotation
11	3700151	3	Hose 120" Both Ends 1/2MP Swivel
12	3700023	2	Hose 96" Both Ends 1/2MPS
13	3700001	1	Hose 72" 1/2MPS, 7/8 M O-Ring
14	3700146	1	Hose 114" Both Ends 1/2MPS
15	3700147	1	Hose 92" Both Ends 1/2MPS
16	3700024	1	Hose 120" 1/2MPS, 7/8 M O-Ring
17	3700149	1	Hose 135" Both Ends 1/2MPS
18	3700150	1	Hose 166" Both Ends 1/2MPS

HYDRAULICS SERIAL NO HI2850 THRU

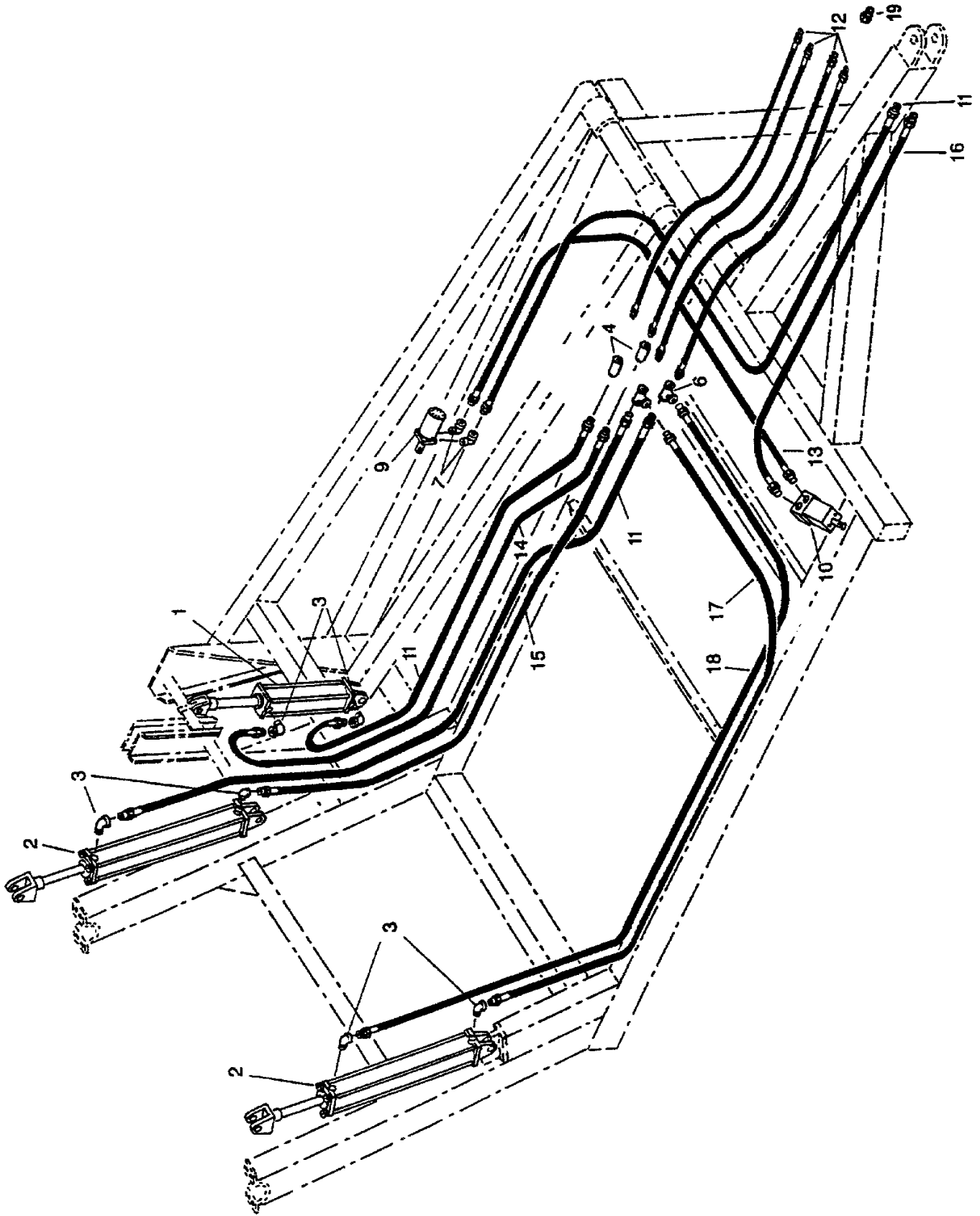

HYDRAULICS SERIAL NO HI2850 THRU

ITEM	PART NO.	QTY.	DESCRIPTION
1	4100073	1	2" x 8" Hyd. Cylinder (Ram)
1A	4100114	1	2-1/2" x 8" Hyd. Cylinder (Ram)
2	4100032	2	3" x 24" Hyd. Cylinder SN 101-2095
2A	4100085	2	3" x 24" Hyd. Cylinder SN 2095 (Ram)
3	3800008	6	90 Degree 1/2" St. Ell.
4	3800051	2	Fitting\1/2FP\Coupling
6	3800009	2	1/2" Tee
7	3800028	2	45 Degree 1/2" St. Ell.
9	3900006	1	203 Orbit Motor
10	3900007	1	2000 Orbit Motor, One Way Rotation
11	3700151	3	Hose 120"Both Ends 1/2MP Swivel
12	3700023	4	Hose 96"Both Ends 1/2MPS
13	3700001	1	Hose 72" 1/2MPS, 7/8 M O-Ring
14	3700146	1	Hose 114" Both Ends 1/2MPS
15	3700147	1	Hose 92" Both Ends 1/2MPS
16	3700024	1	Hose 120" 1/2MPS,7/8 M O-Ring
17	3700149	1	Hose 135" Both Ends 1/2MPS
18	3700150	1	Hose 166" Both Ends 1/2MPS
19	3800505	6	Ftg\1/2NPTF\Quick Coupler

TIRES AND WHEELS

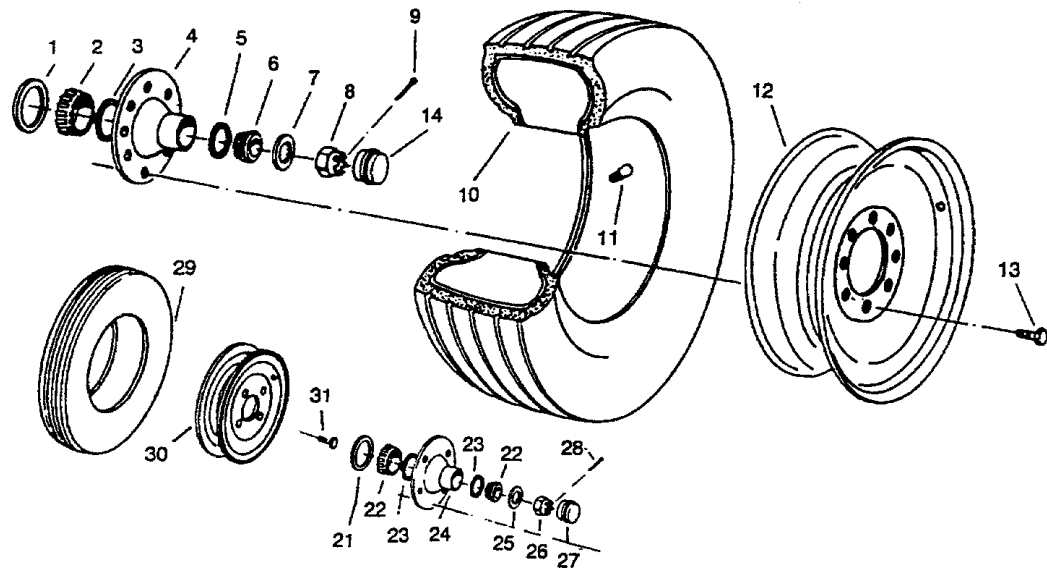

ITEM	PART NO.	QTY.	DESCRIPTION
1	2900030	2	Seal
2	2900029	2	Inner Cone
3	2900028	2	Inner Cup
4	2900026	2	Hub Complete, Seals, Bearings, Cap Bolts
4A	2900027		Hub Only
5	2900025	2	Outer Cone
6	2900024	2	Outer Cup
7	5000055	2	Washer
8	4900054	2	Nut
9	4800120	2	Cotter Pin 3/16 x 1-3/4
10	2600006	2	11L- 16Tire
11	2600404	2	11L- 16 Tube
12	2600607	2	Wheel 16 x 10 - 8-Bolt
13	2600608	16	Bolt
14	2900020	2	Hub Cap
21	2900031	1	Seal
22	2900032	2	Cone
23	2900033	2	Cup
24	2900143	1	Hub
25	5000056	1	Washer
26	4900055	1	Nut
27	2900037	1	Cap
28	4800050	1	Cotter Pin 3/16 x 1-1/2"
29&30	2600805	1	4.00 x 8 Tire and Wheel
29	2600007	1	4.80 x 8 Tubeless Tire
30	2600609	1	Wheel
31	2600610	4	Bolt

WINDROWER MOTOR

ITEM	PART NO.	QTY.	DESCRIPTION
1	6200004	1	5/16" x 1-1/2" Key
2	7501005	1	Seal Kit
3	3900007	1	Complete H2000 Orbit Motor, One Way Rotation

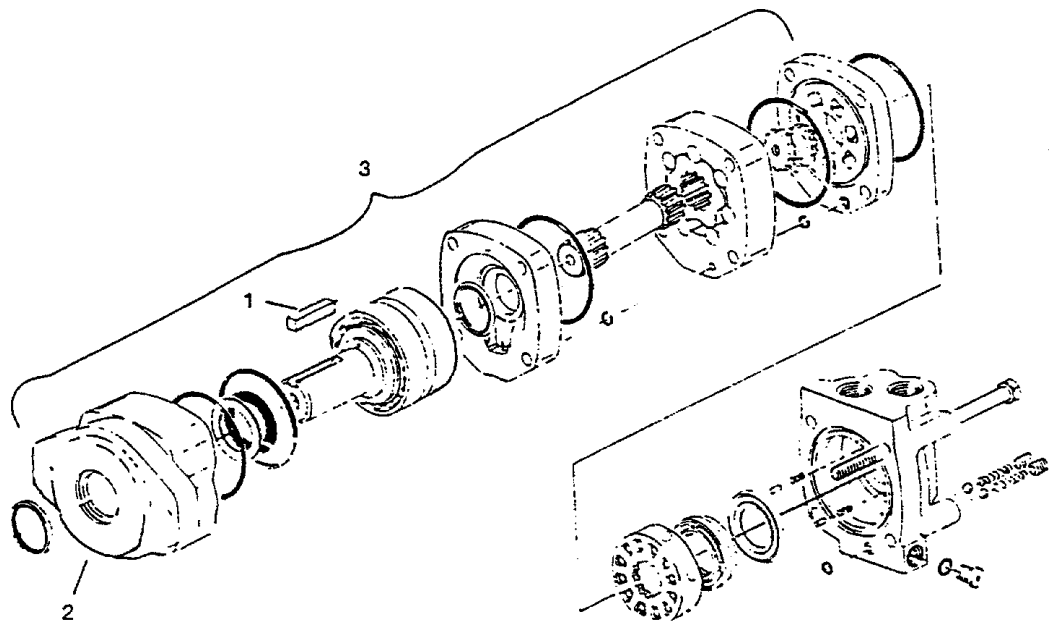

ROCK KICKER MOTOR

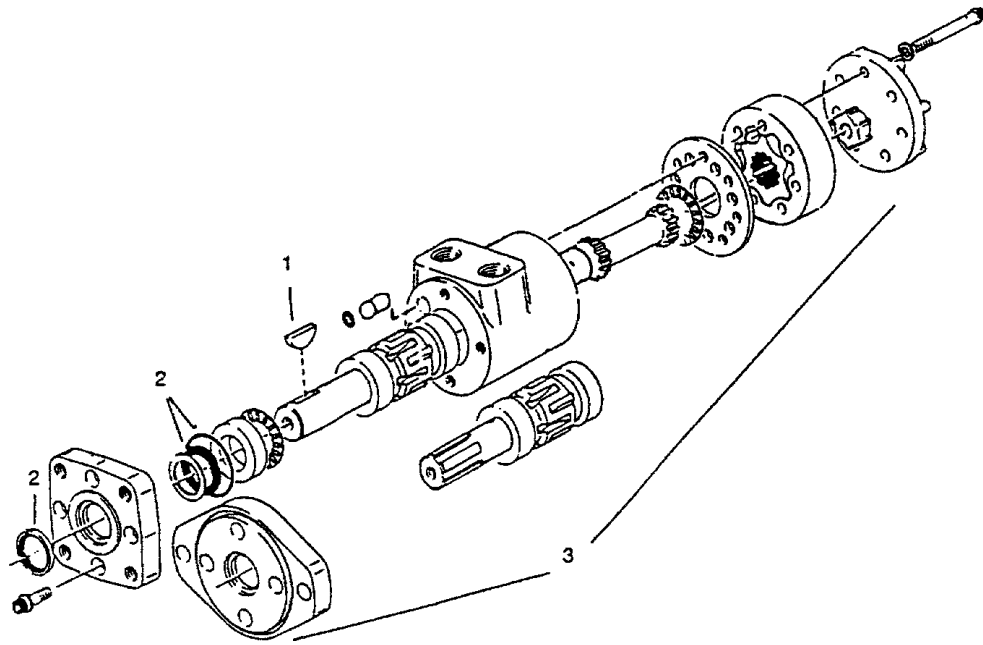

ITEM	PART NO.	QTY.	DESCRIPTION
1	6200003	1	Key, Half Moon, Size 15 Woodruff Key
2	7501038	1	Seal Kit
3	3900006	1	Complete 203 Orbit Motor

CYLINDERS SERIAL NO. 101 THRU 2094

ITEM	PART NO.	QTY.	DESCRIPTION
ROCK WHEEL LIFT CYLINDER			
1	4100010	1	Seal Kit
2	4100011	1	Yoke
3	4100030	2	Pin
4	4100031	2	Key
5	4100073	1	2 x 8 Cyl. Comp. (Cross)
6	4100049	1	Rod
7	4100053	1	Rod End Cap

BUCKET DUMP CYLINDER			
1	4100033	1	Seal
2	4100034	1	Yoke
3	4100030	2	Pin
4	4100031	2	Key
5	4100211	1	3 x 24 Cyl. Comp. (Cross)
6	4100056	1	Rod 1-1/2"
7	4100041	1	Rod End Cap
8	4100042	1	Anchor Cap

* Note: Use same drawing as reference for each cylinder.

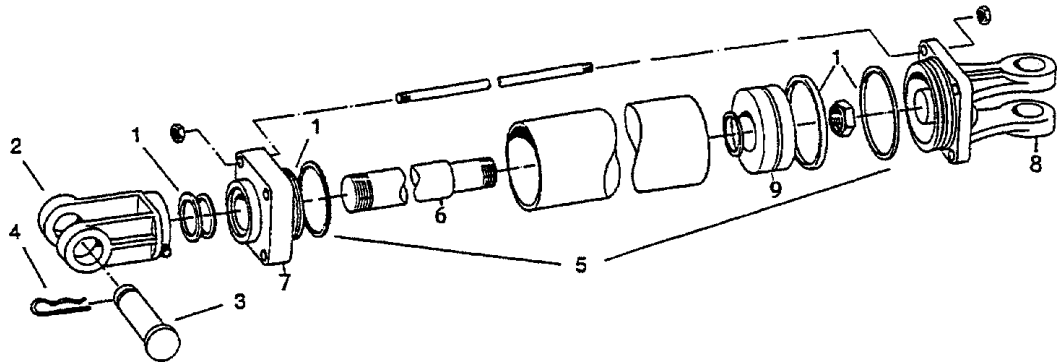

CYLINDERS (RAM) SERIAL NO. 2095 UP

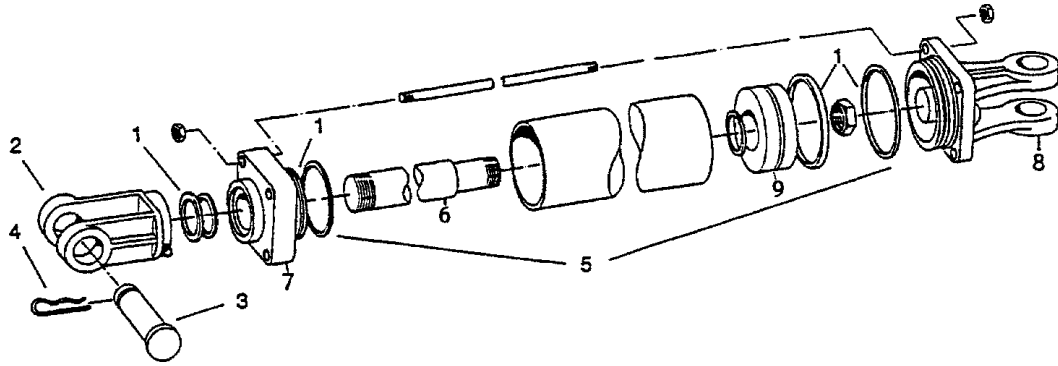

* Note: Use same drawing as reference for each cylinder.

ITEM	PART NO.	QTY.	DESCRIPTION
ROCK WHEEL LIFT CYLINDER			
1	4100093	1	2" Seal Kit (Ram)
5	4100073	1	2 X 8 Hyd. Cylinder (Ram)
6	4100094	1	1" Rod (Ram)
7	4100095	1	2" Gland (Ram)
9	4100092	1	2" Piston (Ram)
BUCKET DUMP CYLINDER			
1	4100099	1	3" Seal Kit (Ram)
5	4100085	1	3 x 24 Hyd. Cylinder (Ram)
6	4100118	1	1-1/2" x 24" Rod (Ram)
7	4100102	1	3" Gland (Ram)
9	4100096	1	3" Piston (Ram)

SELECTOR VALVE (OPTION)

ITEM	PART NO.	QTY.	DESCRIPTION
1	4000115	1	Valve Complete
2	7501012	1	Seal Kit
3	4000036	1	Snap Ring
4	4000037	1	Spring
5	4000038	1	Washer
6	4000039	1	Forward Stop
7	4000001	1	Handle
8	4000002	1	Handle Link Kit
9	4000004	1	Handle Bracket
10	4000029	1	End Cap
	6600147	2	Hyd Lever Rope Adapter
	7500217	1	4" X 14' Rope

See also page 55

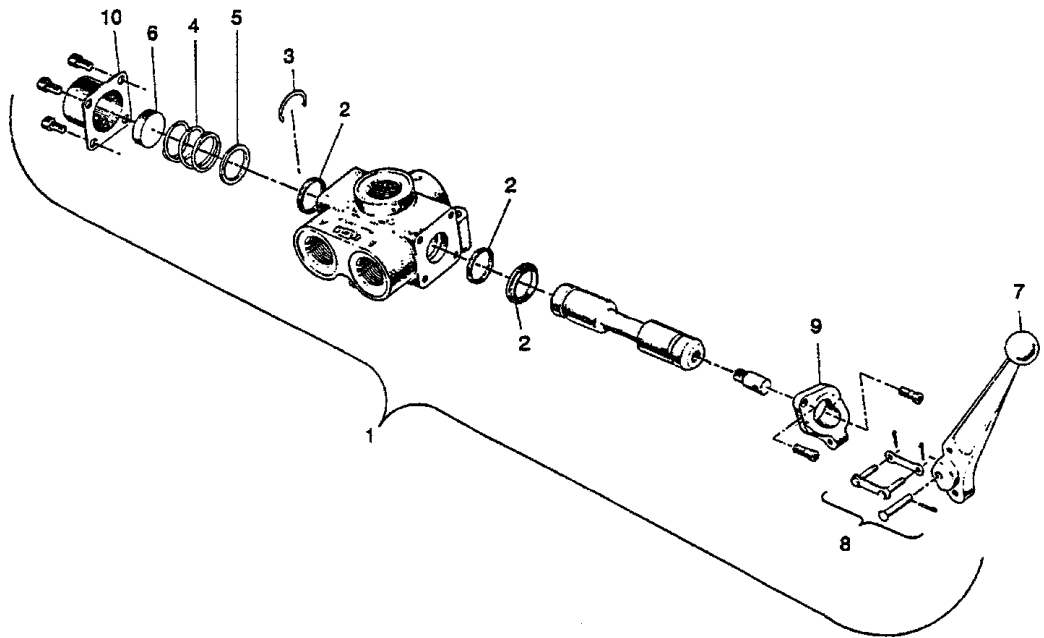

SELECTOR VALVE (OPTION)

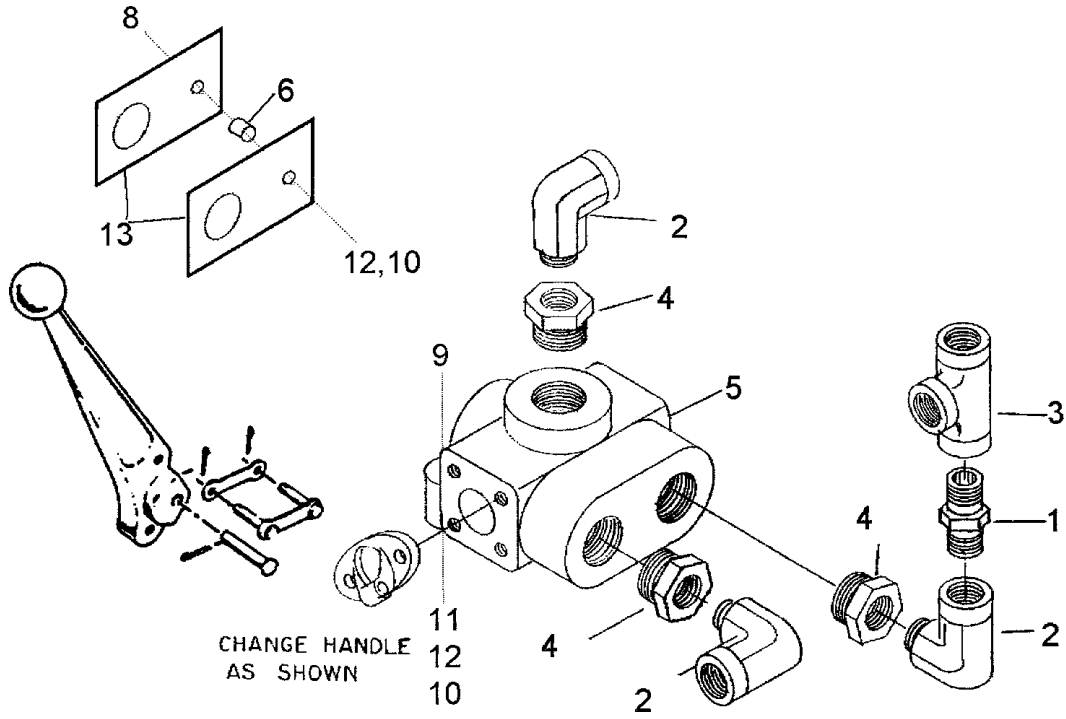

SELECTOR VALVE (OPTION)

ITEM	PART NO.	QTY.	DESCRIPTION
	6600173		KIT\VALVE\ROPE\H-106
1	3800005	1	FTG\1/2MP\CLOSE\NIPPLE
2	3800008	3	FTG\1/2MPX1/2FP\90D\ST;EL
3	3800009	1	FTG\1/2FP\TEE
4	3800119	3	FTG\1-1/16MORX1/2FP\ADPT
5	4000115	1	VALVE\HYD\SLCTR\1-1/16FOR
6	4600089	1	SPACER.5 X 3/8
7	4800067	1	'BOLT\U\3/8\1-1/2""IDX2""OD"
8	4800098	1	BOLT\HEX 3/8X1-1/4\NC
9	4800146	2	BOLT\HEX\3/8X2
10	4900002	5	NUT\HEX\3/8\NC
11	5000001	2	WASH\FLAT\3/8
12	5000019	5	WASH\LOCK\3/8
13	6600147	2	HYD\LEVER ROPE\ADAPT
14	7500212	1	PORCELAIN SPOOL (GUIDE)
15	7500217	1	1/4 ROPE X 14 FT

See Also Page 53.
ITEM 15 NOT SHOWN

NOTE - ITEMS 7, 10, 12 AND 14 ARE SHOWN ON PAGE 40, ROCK WHEEL ASSEMBLY AS ITEMS 65, 64, 63 AND 66.

SEE PAGE 44 FOR HYDRAULIC HOSE LAYOUT.

DRAG PLATE (OPTION)

DRAG PLATE

When using rockpicker on smooth solid terrain, windrower may cause stones to roll ahead of rock wheel.

With drag plate adjusted so lower edge of plate drags, stones will be deflected, preventing them from rolling ahead.

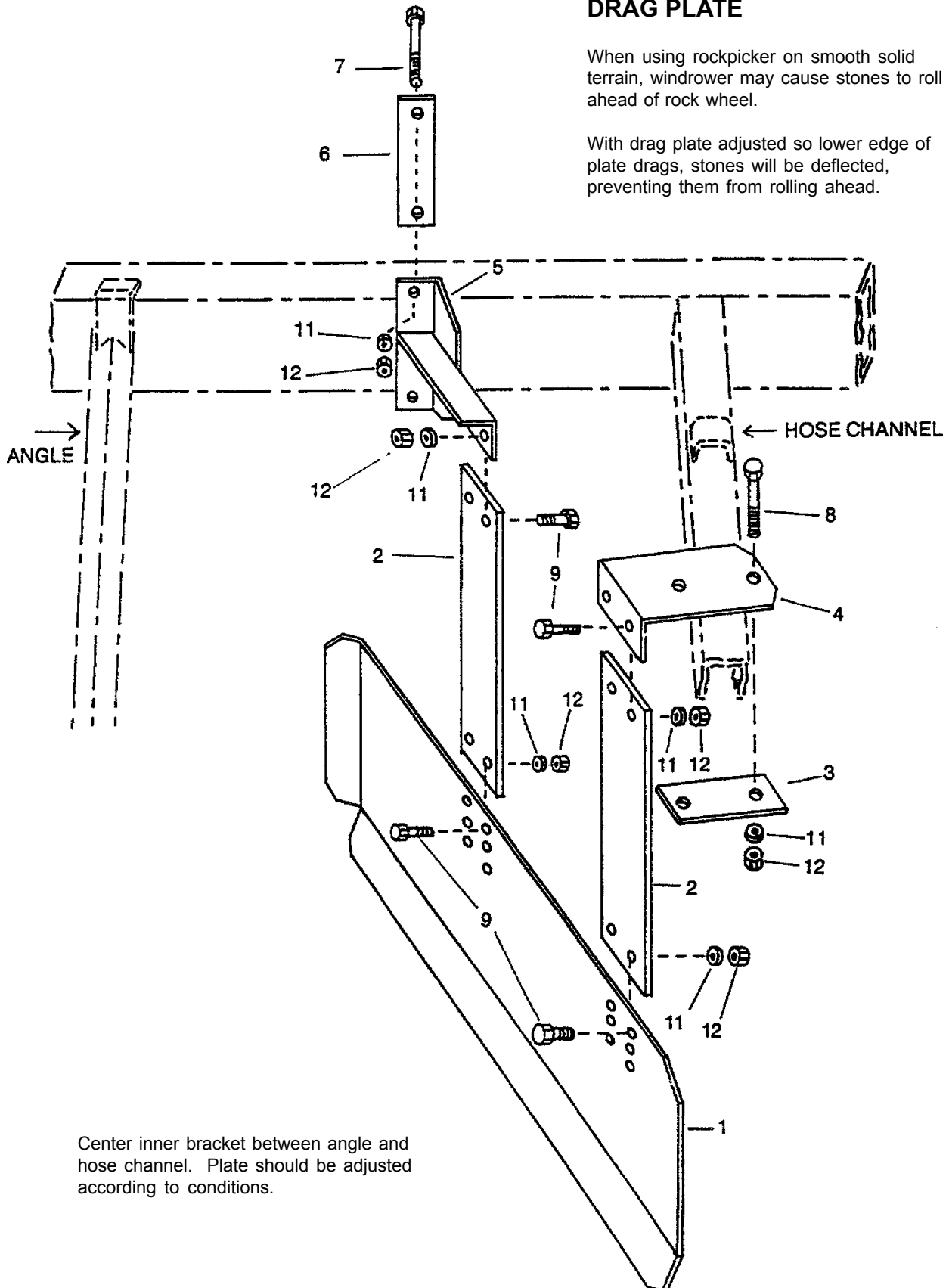

Center inner bracket between angle and hose channel. Plate should be adjusted according to conditions.

DRAG PLATE (OPTION)

ITEM	PART NO.	QTY.	DESCRIPTION
	6600130	1	Drag Plate Kit
1	6600095	1	Drag Plate
2	6600096	2	Rubber Hanger
3	6600097	1	Outer Mount Strap
4	6600098	1	Outer Mount Bracket
5	6600099	1	Inner Mount Bracket
6	6600100	1	Inner Mount Strap
7	4800152	2	3/8" x 4-1/2" Hex Bolt
8	4800197	2	3/8" x 3-1/2" Hex Bolt
9	4800034	8	3/8" x 1-1/2" Hex Bolt
10	5000001	8	3/8" Flat Washer
11	5000019	12	3/8"Lock Washer
12	4900002	12	3/8" Hex Nut

DECALS

HAYBUSTER

ROCK-EZE

HAYBUSTER

← **OIL LEVEL**

6500052

⚠ WARNING

FOR YOUR PROTECTION KEEP ALL SHIELDS IN PLACE AND SECURED WHILE MACHINE IS OPERATING. MOVING PARTS WITHIN CAN CAUSE SEVERE PERSONAL INJURY.

6500040

⚠ WARNING FOR YOUR PROTECTION AND PROTECTION OF OTHERS, PRACTICE THE FOLLOWING SAFETY RULES.

1. BEFORE OPERATING THIS MACHINE, READ THE OPERATOR'S MANUALS SUPPLIED WITH THIS MACHINE AND YOUR TRACTOR.
2. CHECK OPERATORS MANUALS TO BE SURE YOUR TRACTOR MEETS THE MINIMUM REQUIREMENTS FOR THIS MACHINE.
3. READ ALL DECALS PLACED ON THIS MACHINE FOR YOUR SAFETY AND CONVENIENCE.
4. NEVER ALLOW RIDERS ON THE IMPLEMENT OR THE TRACTOR.
5. KEEP OTHERS AWAY FROM THIS MACHINE WHILE IN OPERATION.
6. KEEP ALL SHIELDS IN PLACE WHILE MACHINE IS OPERATING.
7. KEEP HANDS, FEET, LOOSE CLOTHING, ETC., AWAY FROM POWER DRIVEN PARTS.
8. ALWAYS SHUT OFF MACHINE AND ENGINE BEFORE SERVICING, UNLOADING, INSPECTING, OR WORKING NEAR THIS MACHINE FOR ANY REASON. ALWAYS PLACE TRANSMISSION IN PARK OR SET PARK BRAKE AND WAIT FOR ALL MOVEMENT TO STOP BEFORE APPROACHING THIS MACHINE.

6500041

⚠ WARNING

NO RIDERS

SERIOUS PERSONAL INJURY COULD RESULT FROM RIDING ON THE MACHINE.

6500043

H-106

KEEP WHEEL BOLTS TIGHT

6500042

DECALS

ITEM	PART NO.	QTY.	DESCRIPTION
1	6500020	1	Haybuster with Sunburst
2	6500040	2	Warning Keep All Shields in Place
3	6500041	1	Warning For Your Protection
4	6500042	2	Keep Wheel Bolts Tight
5	6500043	1	Warning No Riders
6	6500046	1	Rock-Eze
7	6500047	1	H-106
8	6500147	1	Cylinder Safety Stop
9	6500031	2	Haybuster (Round, White)
10	6500006	1	Decal Kit (ITEM NOT SHOWN)



H-106 ROCK-EZE Documentation Comment Form

DuraTech Industries welcomes your comments and suggestions regarding the quality and usefulness of this manual. Your comments help us improve the documentation to better meet your needs.

- Did you find any errors?
- Is the information clearly presented?
- Does the manual give you all the information you need to operate the equipment safely and effectively?
- Are the diagrams and illustrations correct?
- Do you need more illustrations?
- What features do you like most about the manual? What features do you like least?

If you find errors or have specific suggestions, please note the topic, chapter and page number.

Send your comments to:

DuraTech Industries International, Inc.
P.O. Box 1940
Jamestown, ND 58402-1940
OR

Contact us through our website: www.duratechindustries.net

Thank you for taking the time to help us improve our documentation.

