

AGRICULTURAL MACHINERY

sitrex®
s.r.l.

**ASSEMBLY
USE AND MAINTENANCE**

MK/18

MK/20

1. Warrantee

On delivery, check that the machine has not been damaged during transport and that all the attachments are present. Claims must be made in writing to the agent within 8 days of receipt.

The manufacturer warrants new machinery at the time of delivery to the original purchaser to be free from defects in material and workmanship if properly set up and operated in accordance with this Operator's Manual.

The manufacturer undertakes to repair or replace free of charge any defective part which should be returned by the purchaser (freight prepaid) and found to be defective by inspection authorized by the manufacturer during the warranty period.

This warranty will be valid for 12 (twelve) months from the delivery of goods to the original purchaser.

In case the customer is not in a position to return the defective part to the manufacturer, the manufacturer cannot be held responsible for any cost due for repair or replacement of any part of the machine, he will only supply the part(s) required for the repair and/or replacement.

The warranty is null and void when it is evident that the machine has been improperly used or repaired or however repaired without authorization.

The manufacturer undertakes no responsibility for any obligation or agreement reached by any employers, agents or dealers, which are not in compliance with the above warranty. The manufacturer cannot be held responsible for the consequent damages. This warranty substitutes any other warranty, express or implied, and any other manufacturer's obligation.

2. Technical characteristics

Type of machine		MK/18	MK/20
Number of fingerwheels	n°	18	20
Number of tines for wheels	n°	40	40
Working width	m (feet)	10.2 (33' 5")	11 (36' 1")
Operating speed	km/h (Mph)	22.5 (14)	22.5 (14)
Minimum power required	kW (HP)	40 (55)	40 (55)
Weight	kg (Lbs)	2365 (5210)	2515 (5540)
Tyre size		205 - 75/15	205 - 75/15
Transport width	m (feet)	2.5 (8' 3")	2.5 (8' 3")

SITREX srl reserves the right to make changes or add improvements at any time without notice

3. General instructions for the operation and maintenance

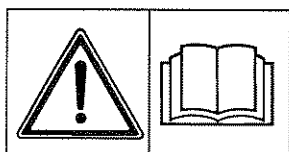

Before starting off for work, be sure that the machine is correctly assembled and in good operating condition.

The front transport arms must always be attached during transport.

While the front transport arms are attached, do not operate for any reason whatsoever the hydraulic cylinders for opening the machine or lifting the rake wheels.

When the machine is in movement, make sure that the brake on the front wheels does not block wheel movement. The wheels must always pivot freely.

When in operation, do not turn around at full speed.

On particularly uneven ground, do not operate with the machine in the fully-opened position (close machine at least 3' compared to the fully-opened position). In addition, operate at a reduced speed.

If it is noticed that the machine is not operating properly (rake wheels putting too much pressure on the ground, front wheels braked, etc.) the problem must be corrected immediately to avoid causing damage to the machine.

If machine maintenance work, repairs or adjustments must be done in the field, they should be done at a spot where the ground is firm and level. Turn off the tractor and apply the parking brake. Use the proper tools and wear suitable protection (safety goggles, work gloves, etc.).

If any maintenance work, repairs or adjustments are done which require that some parts be removed and/or that screws, nuts, pins, etc. be loosened or removed, always make sure that everything is reassembled or retightened as it had been prior to making repairs or adjustments.

Follow the schedule provided for maintenance.

By following these suggestions it will be possible to keep the machine operating safely and efficiently, to the benefit of the user.

IMPORTANT

DURING EXTENDED PERIODS OF INACTIVITY IT IS NECESSARY TO CLOSE COMPLETELY THE CYLINDERS. THIS MUST BE DONE IN SUCH A WAY AS TO PROTECT THE RODS FROM WEATHER EFFECTS.

THE RODS PARTS REMAINING OUTSIDE THE CYLINDER PIPE (WHATEVER REASONS MAY BE) MUST BE CAREFULLY PROTECTED WITH A GREASE LAYER.

4. Assembly instructions

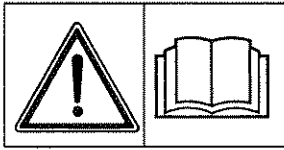

Assembly must be done carefully and accurately, for the safety of the person(s) doing the assembling and to ensure proper machine operation.

Assembly should be done on a flat, solid surface, using the proper tools and wearing suitable clothing, making sure that all people not involved in the assembly be kept at a safe distance. Assemblers must provide suitable lifting mechanisms and supports for stabilizing the partially assembled units, so as to prevent them from falling and causing damage or injury. The steps for assembly are illustrated in following. Depending on the experience of the assemblers and the tools available, it is not necessary that the instructions be followed in the exact order given here, but the safety precautions described above must always be followed carefully and scrupulously.

IMPORTANT

These signs and symbols give information to the operator on how to make the best use of the machine so as to prolong life, avoid damage, optimise work and, above all, to avoid injury to the operator and anyone within range of the machine.

4.1 Warning signs

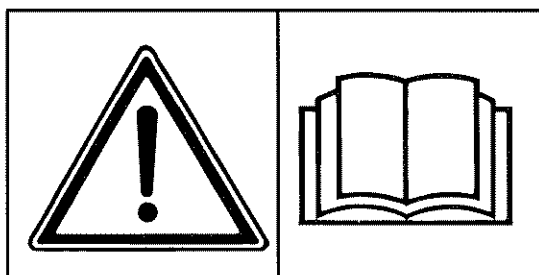

A) Before beginning operations, read the instruction manual carefully.

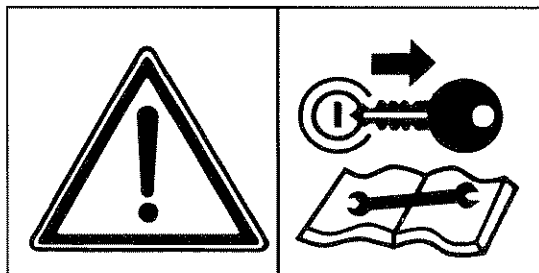

B) Before doing any maintenance or repair work, stop the machine at a suitable spot. Turn off the tractor motor, apply the brake, remove the key from the ignition and consult this manual.

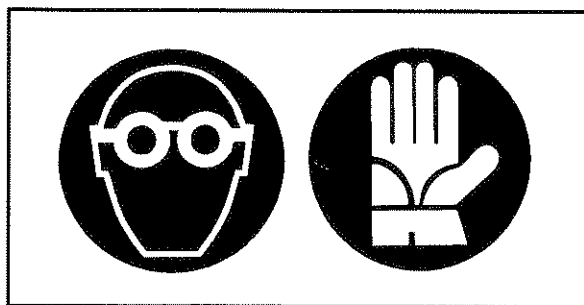

C) This is a warning to use proper accident protection when carrying out maintenance and repairs

4.2 Danger signs

DANGER



Indicates an impending dangerous situation which, if not avoided, will cause death or severe personal injury.

ATTENTION



Indicates a potentially dangerous situation which, if not avoided, could cause death or severe personal injury, including dangers which are present when protection is removed.

CAUTION



indicates a potentially dangerous situation which, if not avoided, can provoke less severe or minor injuries.

4.3 Technical notes

We will provide a few examples to make it easier to choose which of the various accessories to use for each step of assembly. An approximate equivalent of the metric measurements is given in inches.

1) PINS AND SCREWS

Example: a pin with a 25 mm (1") diameter and a screw with an M 16 (5/8") diameter, both 50 mm (2") long, will be listed as:
 D 25 x 50 (D 1" x 2") and M 16 x 50 (D 5/8" x 2").

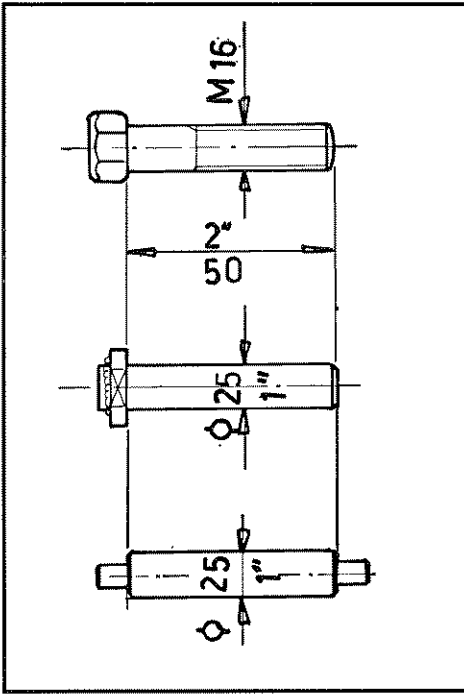

2) SHIMS, SPACERS, BUSHINGS AND WASHERS

Example: a shim, spacer, bushing or washer with an inside diameter of 25 mm (1"), outside diameter of 50 mm (2") and thickness or length of 13 mm (1/2") will be listed as:
 D 25 - 50 x 13 (D 1" - 2" x 1/2").

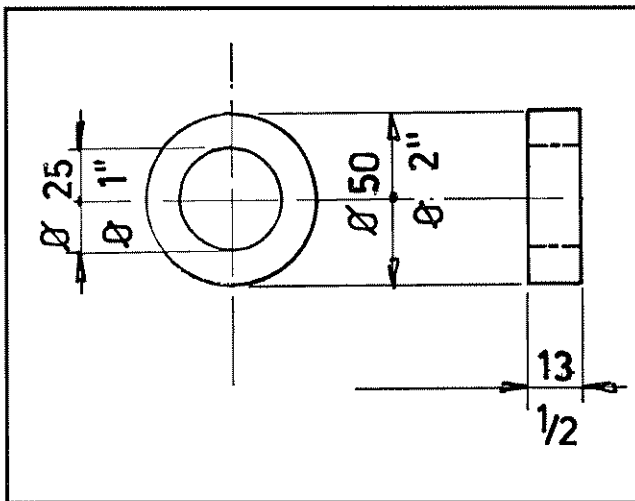

3) NUTS, GREASE NIPPLES

Example: a nut or grease nipple having a thread of M 8 (5/16") will be listed as:
 M 8 (5/16")

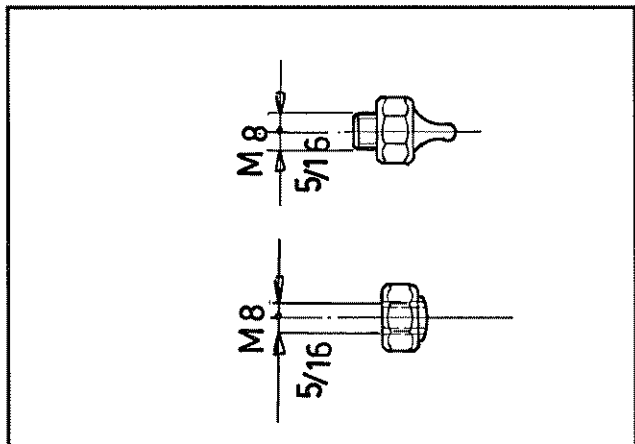

4) PINS AND SPLIT PINS

Example: a pin or split pin having a diameter of 8 mm (5/16") and a length of 50 mm (2") will be listed as:
D 8 x 50 (D 5/16" x 2")

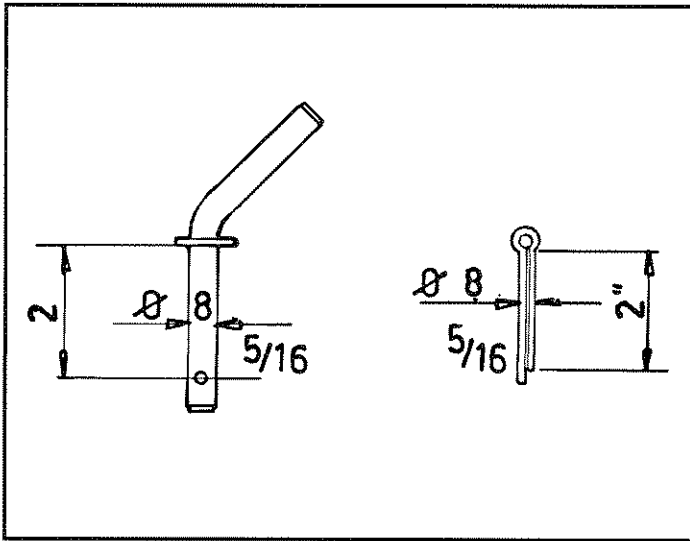

5) CLIPS

Example: a clip with a diameter of 3 mm (1/8") will be listed as:
D 3 mm (1/8")

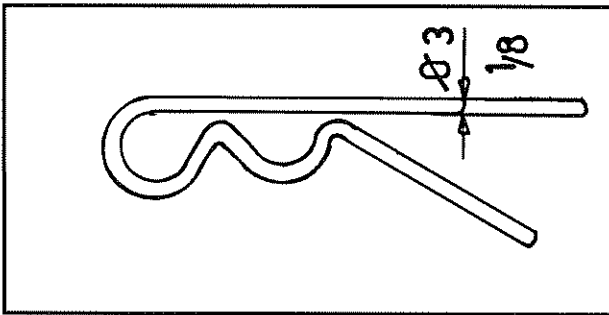

6) SPRINGS

Example: a spring with a wire diameter of 3 mm (1/8"), outside diameter of 25 mm (1") and length of 76 mm (3") will be listed as:
D 3 - 50 x 76 (D 1/8"- 2" x 3")

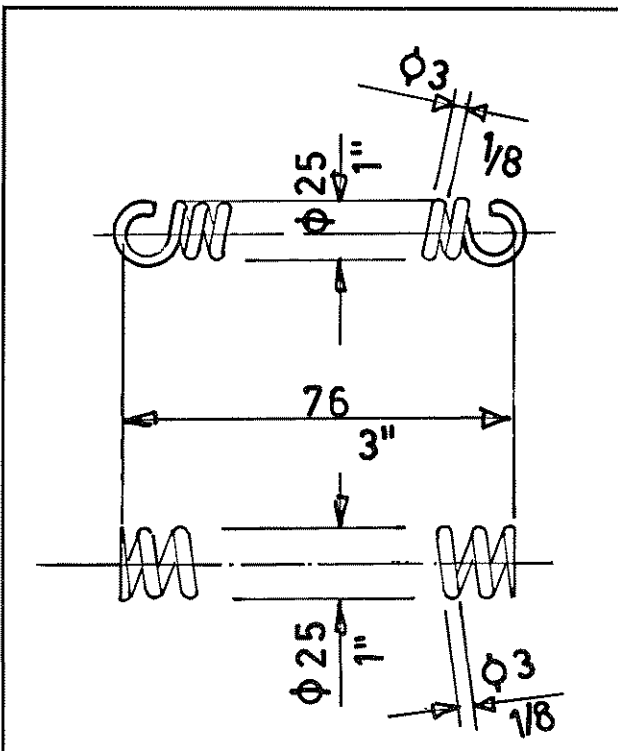

5. GENERAL MAINTENANCE INSTRUCTIONS

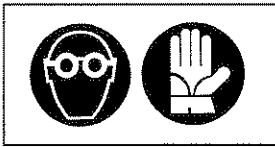

5.1 Repair work

Any repair work must be carried out with the machine at rest and disconnected from the tractor. Do not carry out welding without authorisation and instructions from the manufacturers. Disconnect the machine from the tractor before any welding work in order not to damage the battery. Always use a protective mask, goggles and gloves when welding, sanding or grinding or when using a hammer or drill.

Always work on the machine out of doors. If you have to operate the machine when connected to the tractor in an enclosed area (for example when testing after repair and/or maintenance), ensure that there is sufficient ventilation so as to prevent noxious exhaust gases accumulating. In order to acquire the necessary control and to operate in safety, practise various manoeuvres by simulating those required in the workplace with the help of an experienced person.

5.2 Laying up for extended periods

At the end of the season, or when an extended period of inactivity is envisaged, it is advisable to:

- 1) clean the machine following instructions and allow it to dry;
- 2) check it carefully and replace any damaged or worn parts;
- 3) thoroughly tighten all screws and bolts;
- 4) grease the machine thoroughly and then cover it completely and lay it up in a dry place.

It is to the users advantage to carry out these operations carefully. In this way, he will have a machine in perfect condition when work is restarted.

On restarting work, repeat all the proper checks so as to be certain of working in conditions of maximum safety.

IMPORTANT

During extended periods of inactivity it is necessary to close completely the cylinders. This must be done in such a way as to protect the rods from weather effects.

The rods parts remaining outside the cylinder pipe (whatever reasons may be) must be carefully protected with a grease layer.

5.3 Maintenance direction

All cleaning, lubrication and maintenance operations must be carried out with the machine disconnected from the tractor.

In an emergency with the machine still connected to the tractor, switch off the engine, apply the parking brake, and remove the ignition key from the instrument panel.

Regular, correct maintenance and proper operation are the basic prerequisites for the long-term efficiency and safe operation of the machine.

Pay special attention to all instructions given on signs located on the machine.

All maintenance should be carried out in an area having the proper equipment readily available and in good condition. This area must always be kept clean and dry and must have enough surrounding space to facilitate operations.

Any work must be carried out by trained personnel. Contact the dealer nearest to you.

Respect the warnings and procedure for maintenance and technical assistance given in this manual.

Do not use petrol, solvents or other flammable liquids as detergents.

Use commercial non-flammable and non-toxic solvents, authorised by competent bodies.

Do not use compressed air or water at high pressure to clean the machine. If this is unavoidable, then wear goggles with side protection and limit the pressure as much as possible. When the work is finished, and with the machine disconnected from the tractor, inspect and check the machine completely.

THE FOLLOWING SHOULD BE NOTED IF THE MACHINE IS SCRAPPED:

The machine consists mainly of ferrous material which must be disposed of according to the regulations in force in the country concerned.

There is also a small amount of plastic which must be disposed of according to the regulations in force in the country concerned.

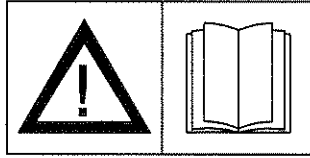

ASSEMBLY



THIS NOTE APPLIES TO ALL MODELS

To obtain correct assembly, when fitting joining sections A and B by using screws E and nuts F, before tightening bolts E-F, it is necessary to turn joining sections C and D in direction shown by the arrows, as much as allowed by clearance between screw E and holes G. Then, it is necessary to check that wheel lift pipes H fit in and slide freely into supports L of sections A-B-C-D. At this point it is possible to tighten bolts and nut E-F.

These instructions must be followed each time sections are added on.

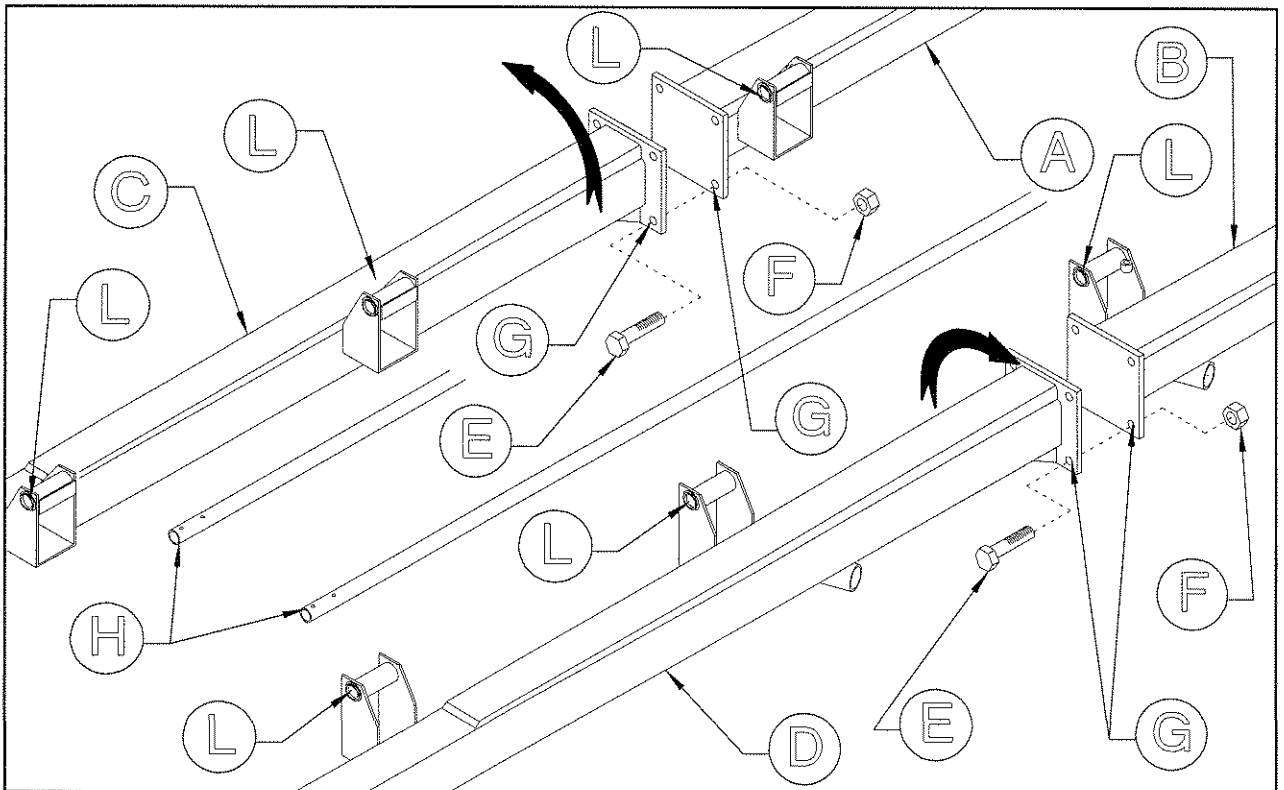

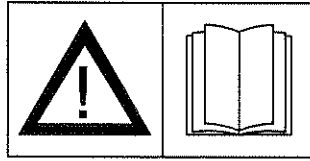

ASSEMBLY STEPS

In the steps for assembly we will use terms "RH parts" and "LH parts". The distinction is conventionally made looking at the machine from the rear. For the purpose of simplification, we will illustrate machine assembly for one side only: since the machine is symmetrical, each operation must be done on both sides.

⚠ ATTENTION!!!

1

Fit bushings 4 on proper seats of wheel supports 2-3.

Attach the wheel supports 2-3 (RH-LH) to the cross member assembly 1 using pins 5, washer 6-7 and screws 8.

To identify parts 2-3 (RH-LH) see the next step.

Fit in proper seats grease nipple 9-10.

In this step, you will use:

Item 4: 4 bushings dia.50-60x50 (dia 2"-2³/₈x2")

Item 5: 2 pins dia.50x190 (dia.2"x7¹/₂")

Item 6: 2 washers dia.23-75x12 (dia.29/32"-3"x1/2")

Item 7: 2 grower washers dia.23-35x4 (dia.29/32"-1³/₈x5/32")

Item 8: 2 screws M22x50 (7/8"x2")

Item 9-10: 4 grease nipples M8 (5/16")

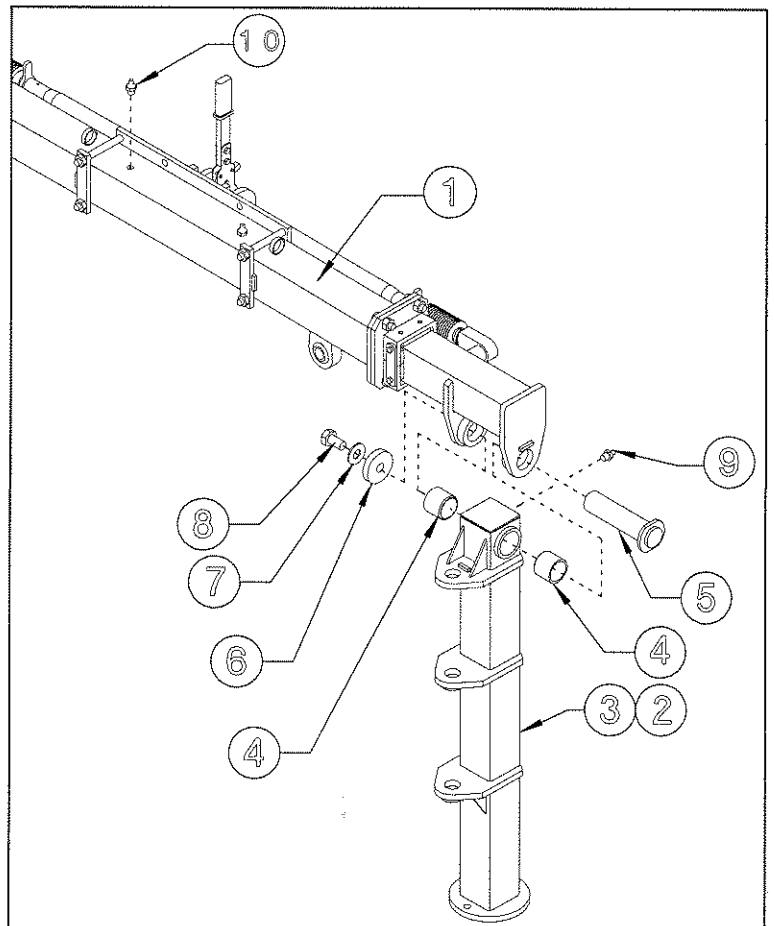

2

For correct assembly, the RH support 2 and the LH support 3 must lean in slightly towards the center of the machine.

After assembly, they must have the measurements given. At this point, before moving on to step 5, keep in mind that the assembly is unstable and therefore it is recommended that extreme caution be used.

NOTE: For the windrow width's adjustment see page 46.

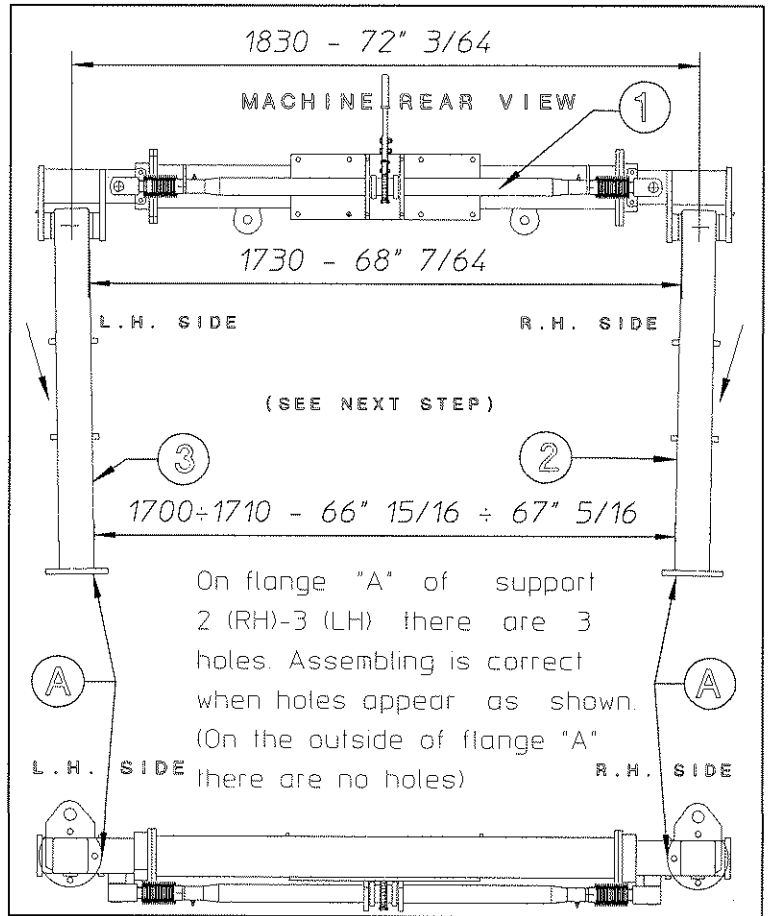

⚠ ATTENTION!!!

3

Fit tie-rods in relevant seats of unit 1 and wheel supports 2 & 3 (RH-LH). Insert pins 5 in holes A-B. Lock pins 5 by using washers 6 and screws 7. Insert pins 8 in holes C-D. Lock pins 8 by using spring pins 9.

*NOTE: If hole of tie-rod 4 does not line-up with holes "C" of wheel supports 2 & 3, loosen nut "E" and turn tie-rod's head 4 until holes line-up.

Keep in mind the warnings of previous point.

Then, lock again nut "E".

In this step, you will use:

- Item 5: 2 pins \varnothing 25x70 (\varnothing 1"x 2 3/4")
- Item 6: 2 washers \varnothing 12-40x4 (\varnothing 1/2" - 1 9/16"x 5-32")
- Item 7: 2 screws M12x20 (5/32"x13/16")
- Item 8: 2 pins \varnothing 30x110 (\varnothing 1 3/16"x4 5/16")
- Item 9: 4 spring pins \varnothing 8x50 (\varnothing 5/16"x2")

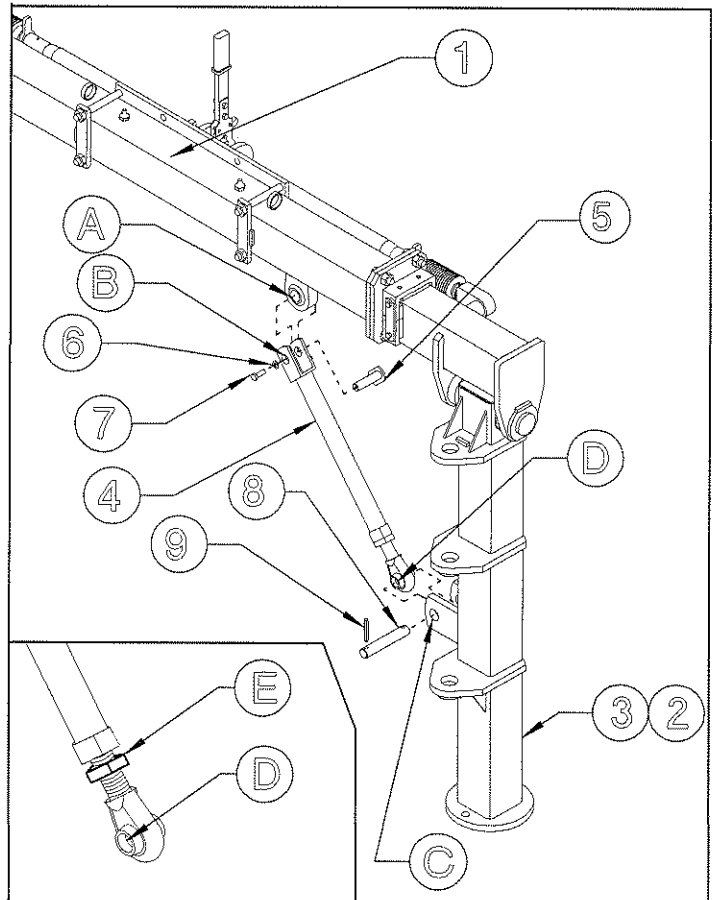

⚠ ATTENTION!!!

4

Attach wheel hubs 1 to supports 2-3 using screws 4 and nuts 5. Mount wheels 6 to hubs 1 using special nuts 7.

In this step, you will use:

Item 4: 6 screws M16 x 50 (dia 5/8" x 2")

Item 5: 6 nuts M16 (dia 5/8")

Item 7: 10 nuts M16 (dia 5/8")

NOTE: the spherical side "A" off the nut 7 must be always turned towards the wheel rim flange.

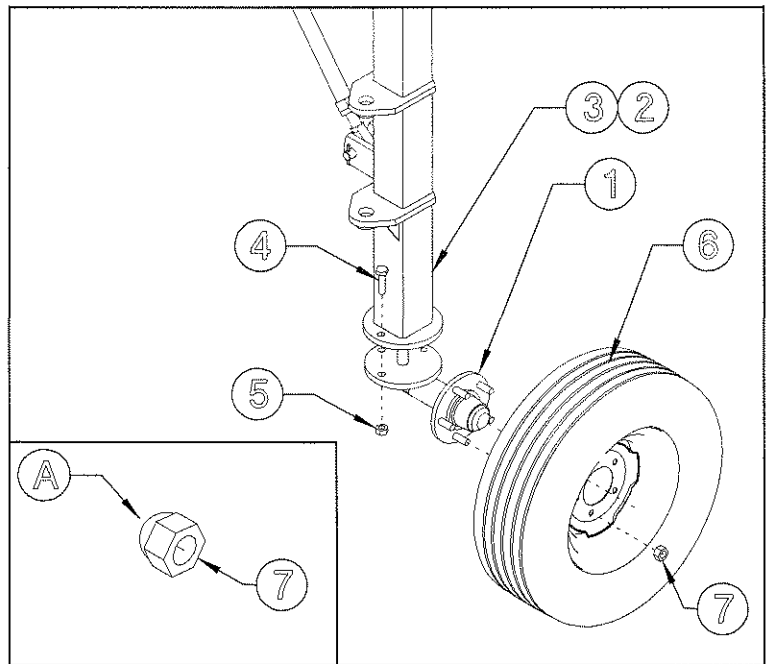

⚠ ATTENTION!!!

5

Assembly 1 must be fully firmly stabilized. Wheels must be chocked with chocks 2 and a support 3 must be placed under the cross member. The forks 4 of a forklift may also be used to support the assembly.

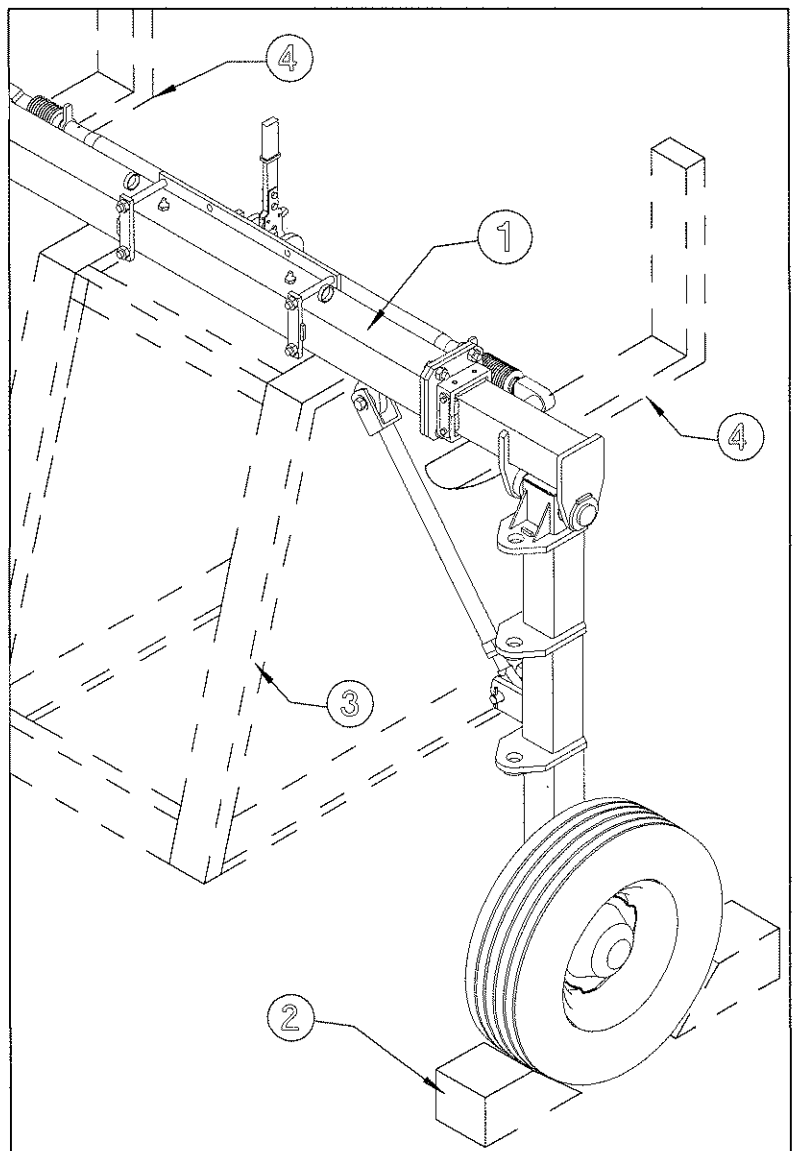

⚠ DANGER !!!

6

Attach the rake wheel sections 3 & 4 (RH-LH) and reinforcements 10 & 11 (RH-LH) to supports 1 & 2 (RH-LH) using pins 5, washers 6 and screws 7. Attach grease nipples 8 in the proper holes.

*Note: bushing "A" of reinforcements 10 & 11 (RH-LH) must be turned to the machine outward.

In this step, you will use:

- Item 5: 2 pins $\varnothing 35 \times 615$
($\varnothing 1 \frac{3}{8}'' \times 24 \frac{7}{32}''$)
- Item 6: 2 washers $\varnothing 12-40 \times 4$
($\varnothing 1/2''-1 \frac{9}{16}'' \times 5/32''$)
- Item 7: 2 screws M12 x 20
($15/32'' \times 13/16''$)
- Item 8: 4 grease nipples M8
($5/16''$)

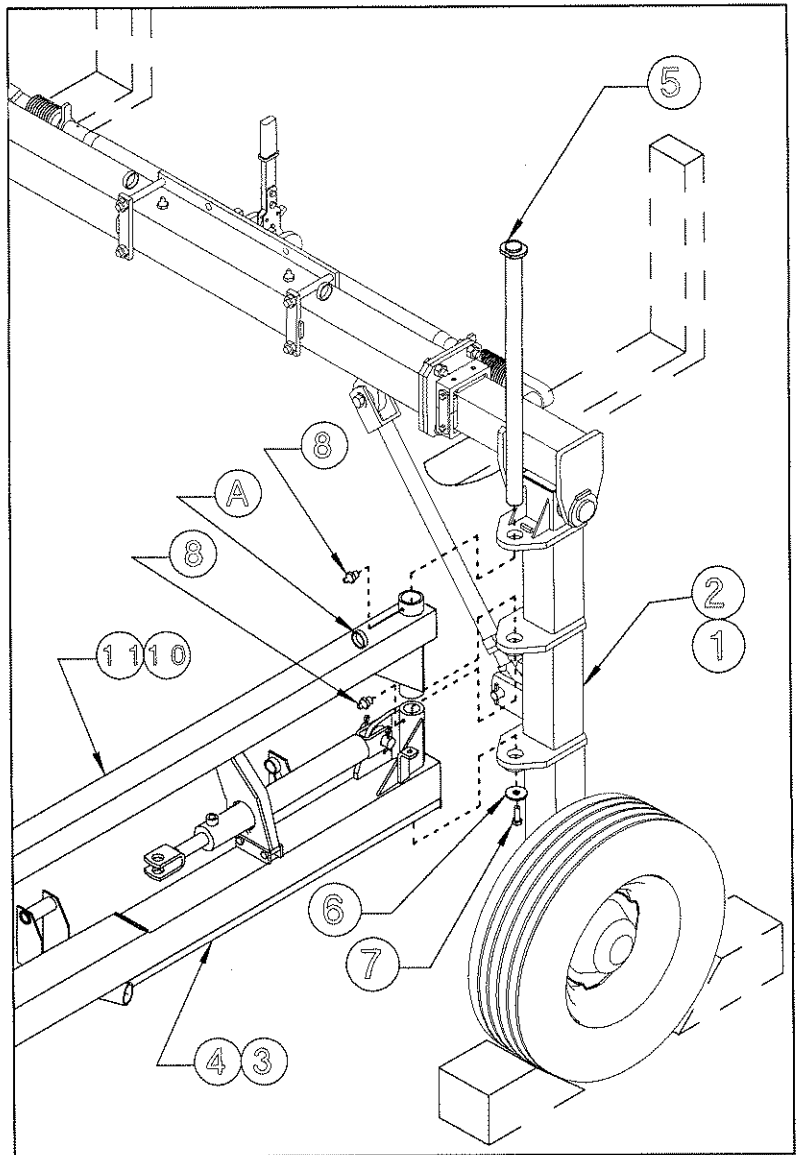

⚠ DANGER !!!

7

Fit to initial sections 1 & 2 (RH-LH) and reinforcements 3 & 4 (RH-LH) sections 5 & 6 (RH-LH) using screws and nuts 7 & 8 and screws and nut 9 & 10.

In this step, you will use:

- Item 7: 8 screws M16 x 45
($5/8'' \times 1 \frac{3}{4}''$)
- Item 8: 8 nuts M16 ($5/8''$)
- Item 9: 8 screws M14 x 45
($9/16'' \times 1 \frac{3}{4}''$)
- Item 10: 8 nuts M14 ($9/16''$)

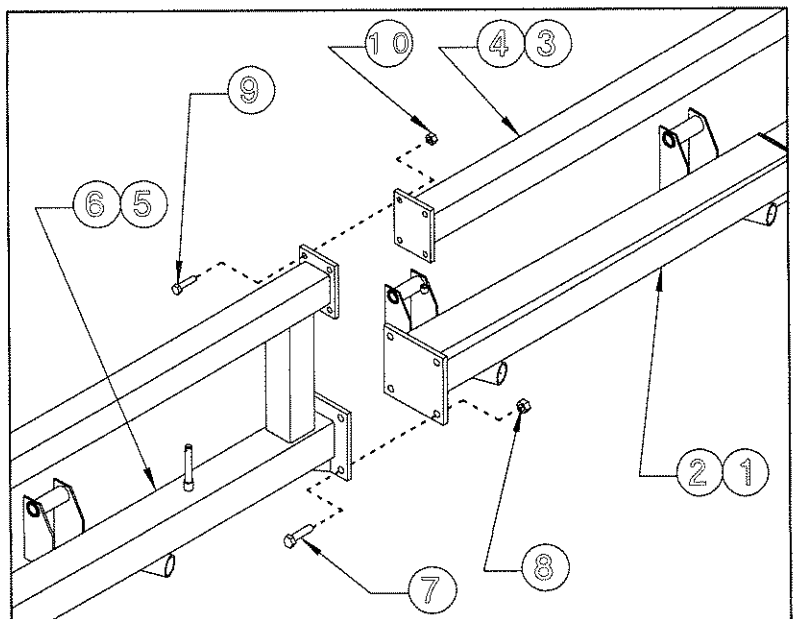

⚠ DANGER !!!

8

Attach sections 3 & 4 (RH-LH) to sections 1 & 2 (RH-LH) using screws 5 and nuts 6. Attach reinforcements 7 & 8 (RH-LH) to sections 1 & 2 (RH-LH) using screws 9 and nuts 10 and sections 3 & 4 (RH-LH) using washers 11, screws 12 and nuts 10.

In this step, you will use:

Item 5: 8 screws M16 x 45
(5/8" x 1 3/4")

Item 8: 8 nuts M16 (5/8")

Item 9: 8 screws M14 x 45
(9/16" x 1 3/4")

Item 10: 16 nuts M14 (9/16")

Item 11: 8 washers $\varnothing 15$ (19/32")

Item 12: 8 screws M14 x 160
(9/15" x 6 3/8")

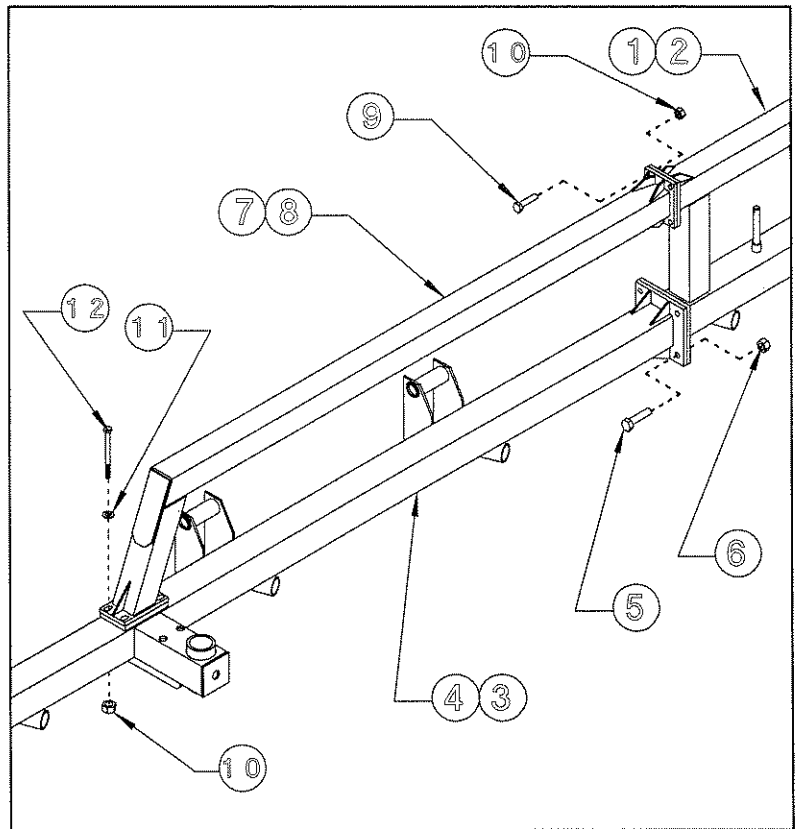

9

When reaching this point, work with great caution, as the machine is not stable.

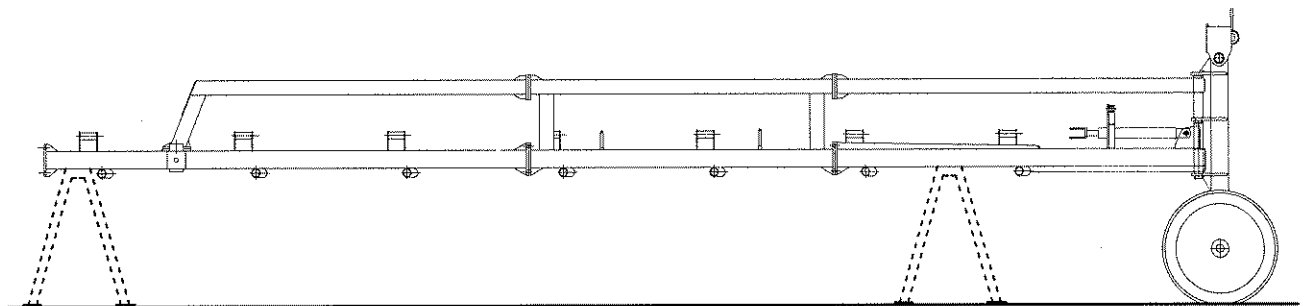

⚠ DANGER !!!

10

Insert bushings 5 in the holes in sections 1 & 2 (RH-LH) shown in the illustration. Place the antifriction washer 4 on the pin of wheel assembly 3, and insert the wheel assembly pin in the correct holes in sections 1 & 2 (RH-LH) and secure it with the flanged bushing 6 and the spring pin 7. Attach grease nipples 8 in the correct holes of sections 1 & 2.

In this step, you will use:

Item 4: 2 washers $\varnothing 50-76 \times 5$
($\varnothing 2"-3" \times 3/16"$)

Item 5: 4 bushings $\varnothing 50-60 \times 50$
($\varnothing 2"-2 3/8" \times 2"$)

Item 7: 2 spring pins $\varnothing 10 \times 80$
($\varnothing 13/32" \times 3 5/32"$)

Item 8: 2 grease nipples M8
($5/16"$)

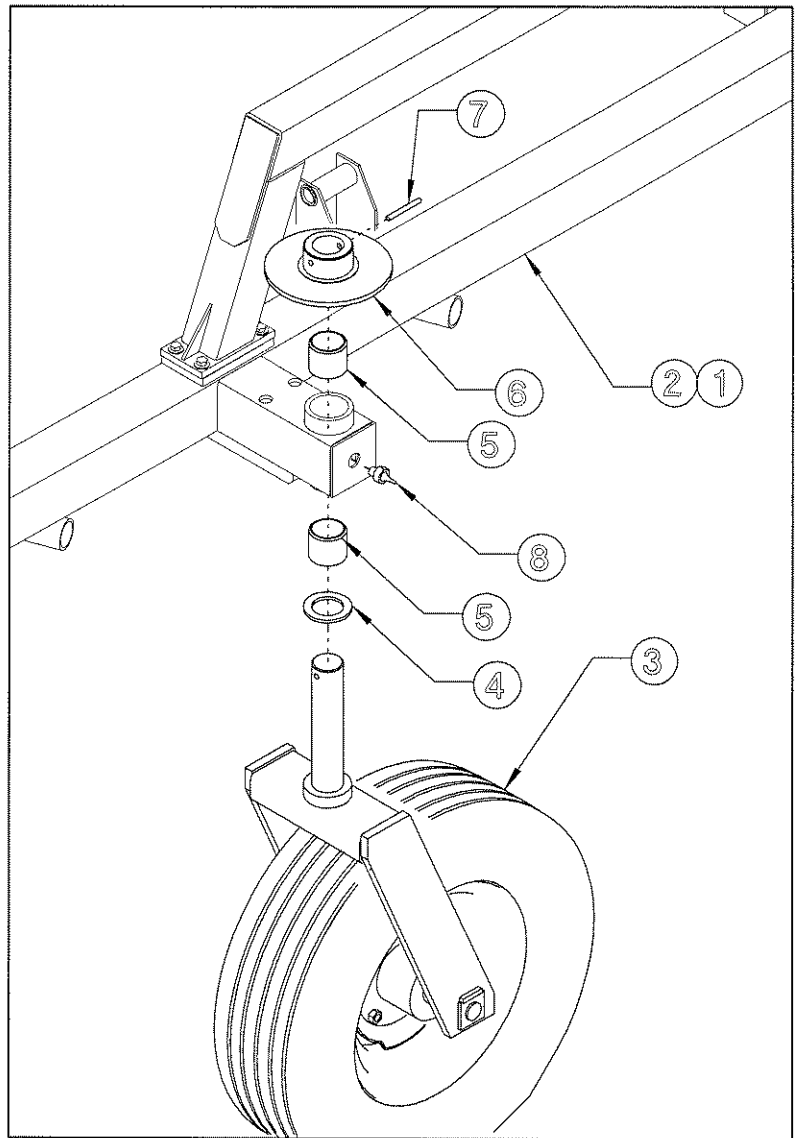

⚠ CAUTION !!

11

Place plate with screw 2 under flange 1 as shown in the illustration. Place upper plate 3 over screw 2, followed by spring 4 and washer 5 and tighten with nut 6.

In this step, you will use:

Item 4: 2 springs $\varnothing 5-30 \times 45$
($\varnothing 13/64"-1 3/16" \times 1 25/32"$)

Item 5: 2 washers $\varnothing 12-36 \times 2.5$
($\varnothing 15/32"-1 27/64" \times 3/32"$)

Item 6: 2 nuts M12 ($15/32"$)

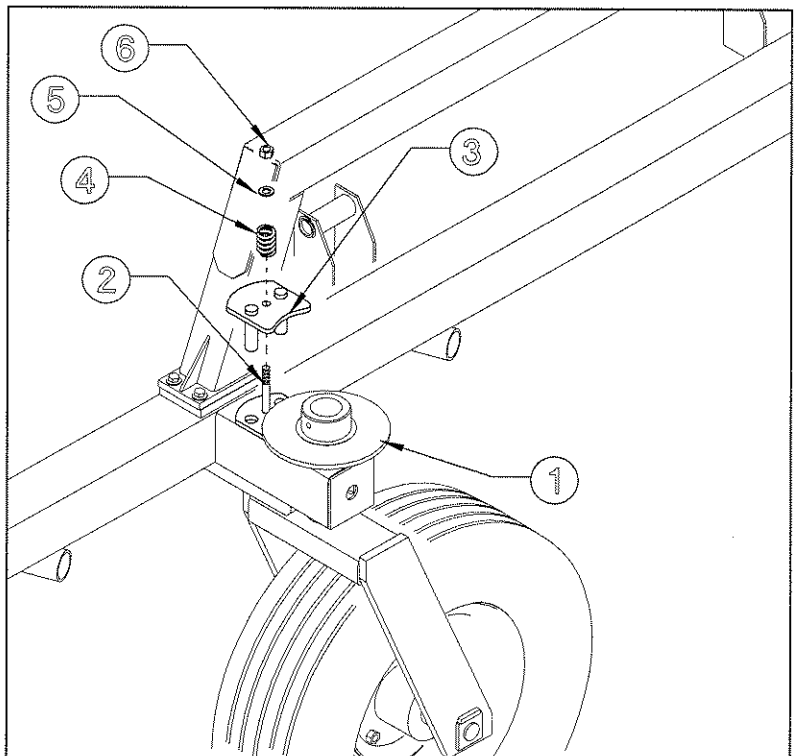

The machine is now resting on four wheels and is thus more stable; however, caution should still be used for the remaining assembly steps. To make assembly easier, it is recommended that the machine sections opened out.

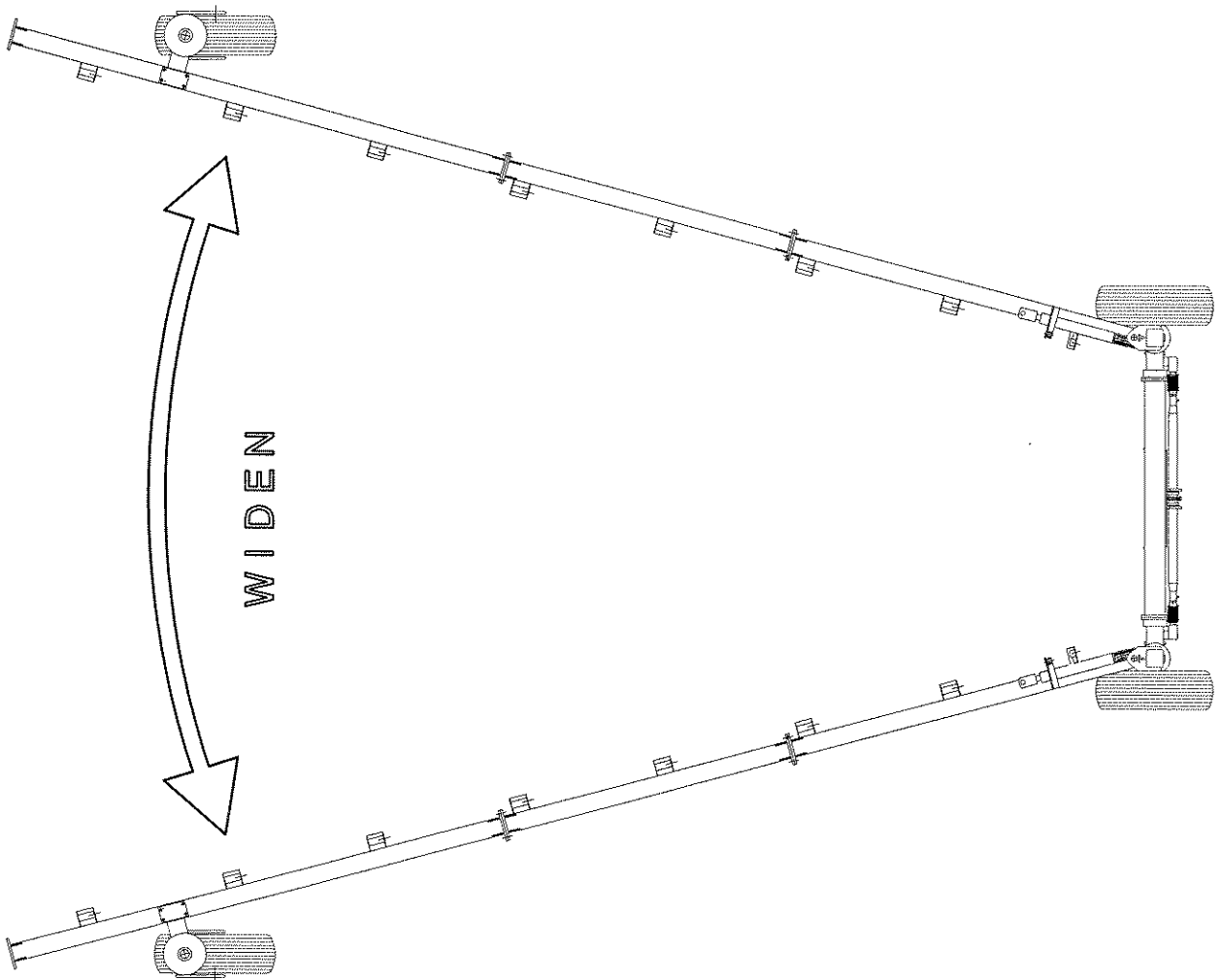
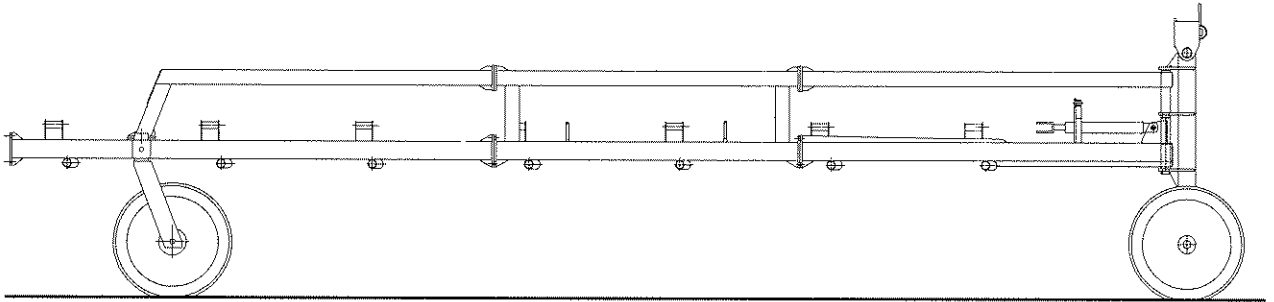

⚠ CAUTION !!

13

Attach end sections 3 & 4 (RH-LH) to sections 1 & 2 (RH-LH) using screws 5 and nuts 6.

Attach reinforcements 7 to sections 3 & 4 and reinforcements 8 & 9 using counterplates 10, screws 11 & 12 and nuts 13.

In this step, you will use:

Item 5: 8 screws M16 x 45
(5/8" x 1" 3/4)

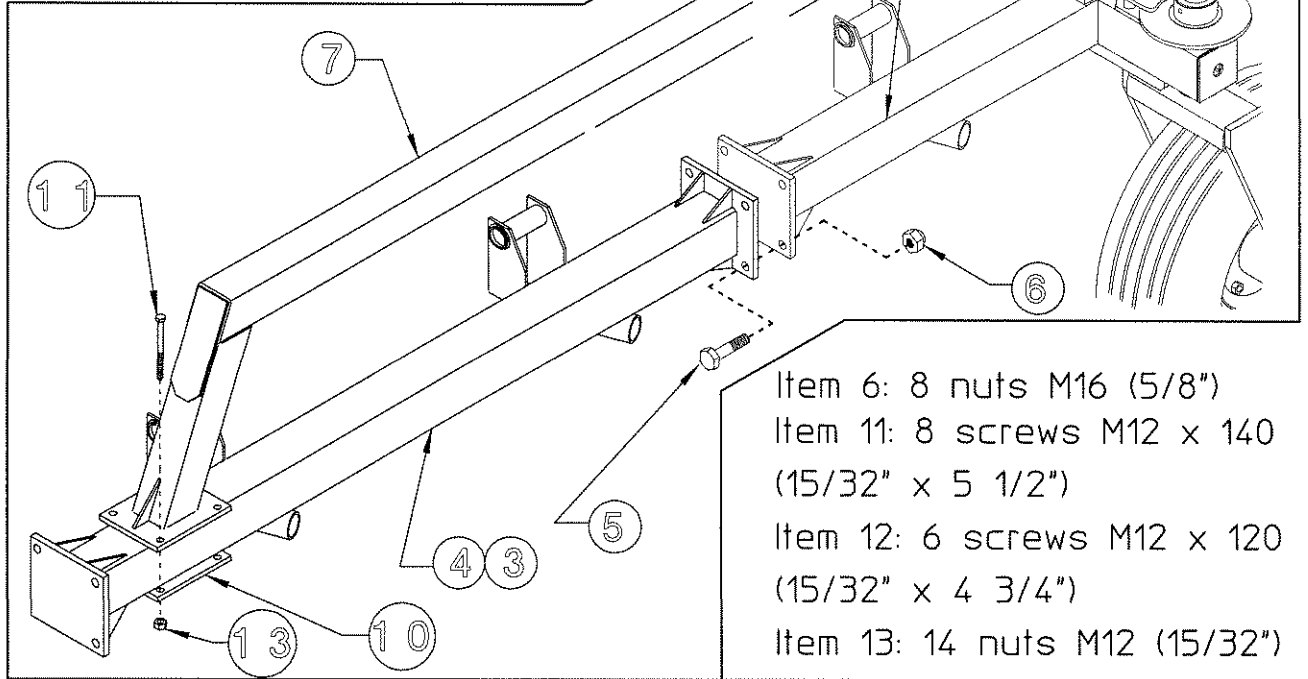

⚠ CAUTION !!

14

(MK 20 ONLY)

Attach end sections 3 & 4 (RH-LH) to sections 1 & 2 (RH-LH) using screws 5 and nut 6.

In this step, you will use:

Item 5: 8 screws M16 x 45
(5/8" x 1" 3/4)

Item 6: 8 nuts M16 (5/8")

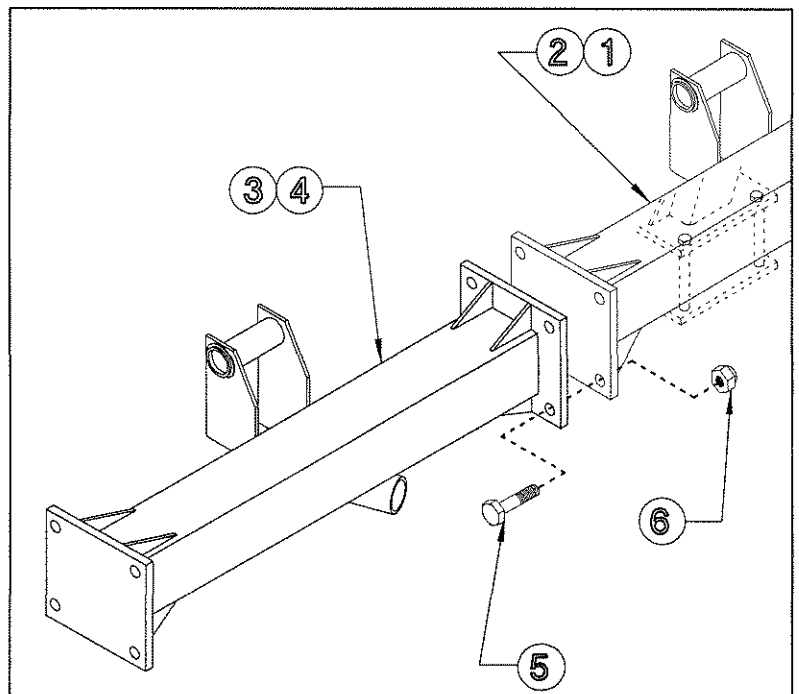

15 ⚠ CAUTION !!

Attach supports 3 & 4 (RH-LH) to sections 1 & 2 (RH-LH) using screws 5 and nuts 6. Place supports 7 & 8 (RH-LH) with washers 9 and screws 10. Note: do not tighten the screws 10. Attach grease nipples 11 in the correct holes of supports 3 & 4. Attach grease nipples 12 in the correct holes of supports "A" and repeat the same operation for all supports of the machine.

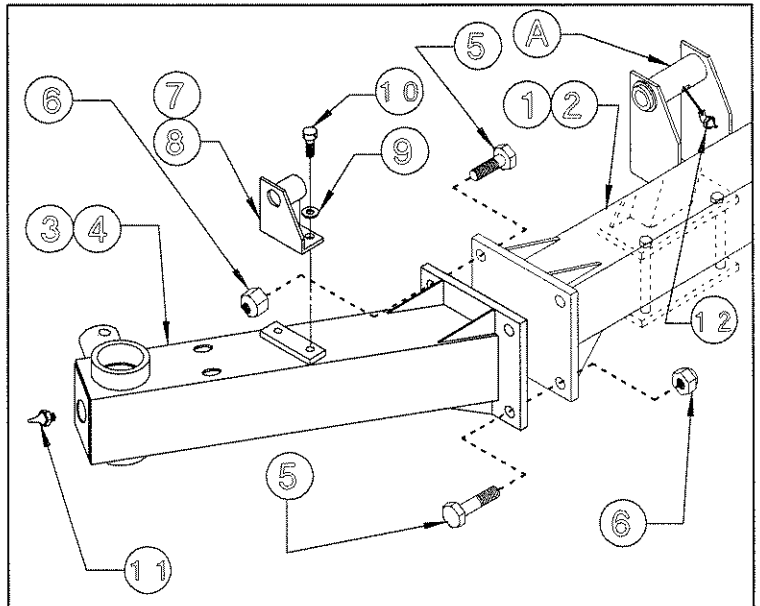

In this step, you will use:
 Item 5: 8 screws M16x45 (5/8"x1 3/4")
 Item 6: 8 nuts M16 (5/8")
 Item 9: 4 washers $\varnothing 10.5-21 \times 2$ ($\varnothing 27/64"-13/16" \times 5/64"$)

Item 10: 4 screws M10x16 (3/8"x5/8")
 Item 11: 2 grease nipples M8 (5/16")
 Item 12: 20/18 grease nipples M6x45° (1/4"x45°)

⚠ CAUTION !!

16

Insert bushings 5 in the holes in supports 1 & 2 (RH/LH) shown in the illustration. Place the washers 4 on the pin of wheel assembly 3, and insert the wheel assembly pin in the correct holes in supports 1 & 2 and secure it with the flanged bushing 6 and the spring pin 7. Place plate with screw 8 under flange 6 as shown in the illustration. Place upper plate 9 over screw 8, followed by spring 10 and washer 11 and tighten with nut 12.

In this step, you will use:
 Item 4: 2 washers $\varnothing 50-76 \times 5$ ($\varnothing 2"-3" \times 3/16"$)
 Item 5: 4 bushings $\varnothing 50-60 \times 50$ ($\varnothing 2"-2 3/8" \times 2"$)
 Item 7: 2 spring pins $\varnothing 10 \times 80$ ($\varnothing 13/32" \times 3 5/32"$)
 Item 10: 2 springs $\varnothing 5-30 \times 45$ ($\varnothing 13/64"-1 3/16" \times 1 25/32"$)
 Item 11: 2 washers $\varnothing 12-36 \times 2.5$

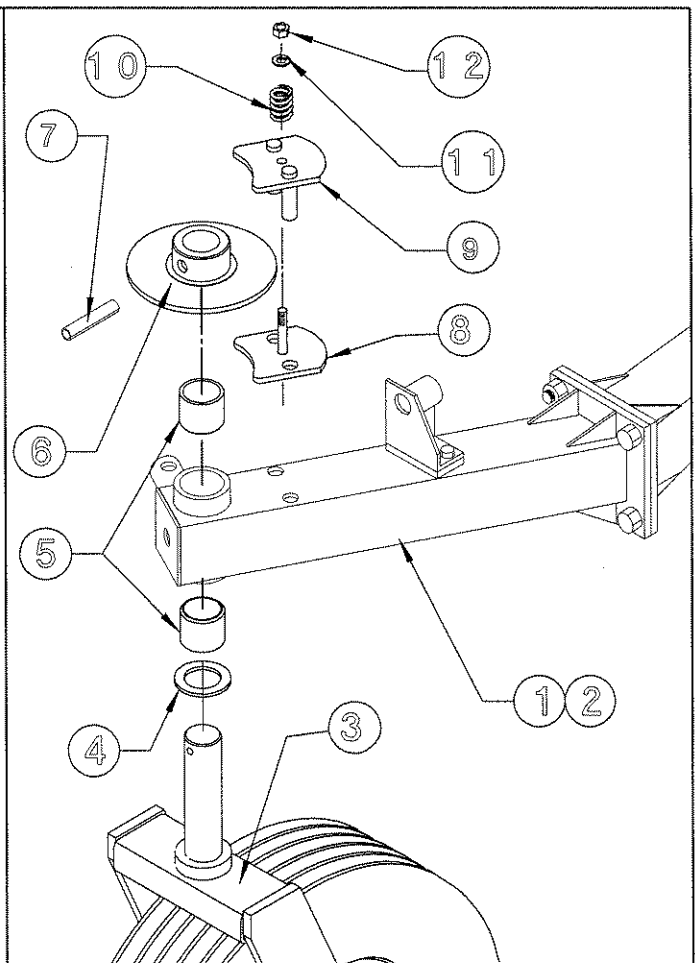

($\varnothing 15/32"-1 27/64" \times 3/32"$)
 Item 12: 2 nuts M12 (15/32")

⚠ DANGER !!!

17

As a first step: need to remove from unit 1 the nuts 2 and plates 3. Nuts 2 and plates 3 belong to the and cannot be used again, while screws 4 will be used again .

This operation is to be carried out with the aid of supports and a jack or hoist of suitable capacity. Weight of part 7 kg 140 = 310 lbs.

Attach drawbar 7 to cross member assembly 1 using counterplate 6, screws 4 and nuts 5.

In this step, you will use:

Item 4: 8 screws M16 x 165
(5/8" x 6 1/2")

Item 5: 8 nuts M16 (5/8")

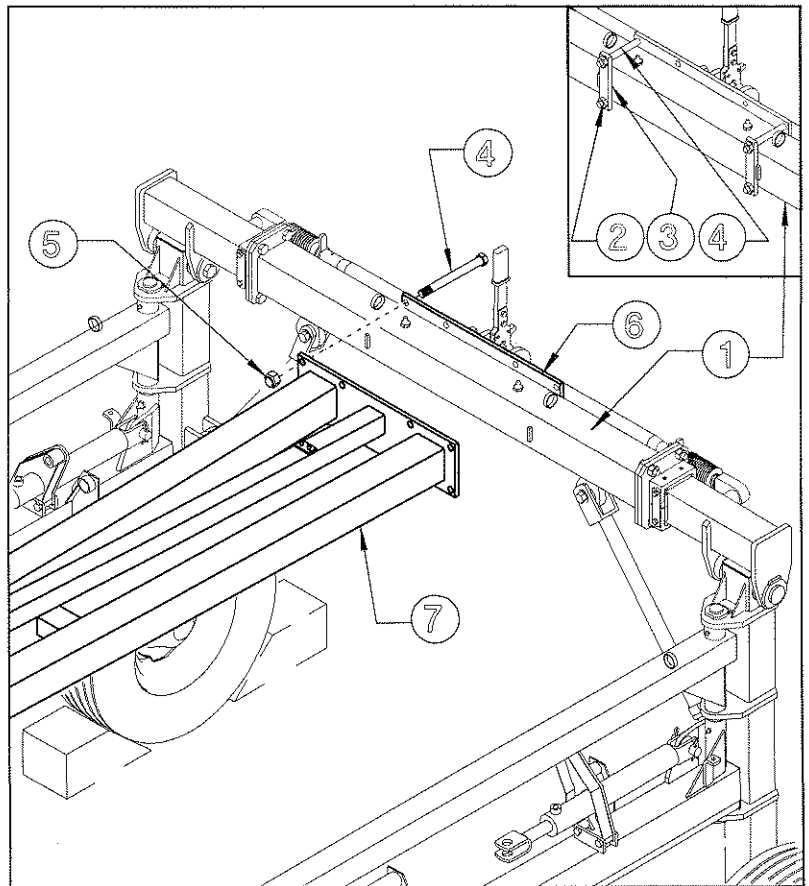

⚠ DANGER !!!

18

The rear drawbar section 1 must be stable, so it must be held either by a jack or hoist of suitable capacity or support 2. (weight 140 kg=310 lbs)

Attach drawbar section 3 (weight kg 100 = 185 lbs) to drawbar section 1 using screws 4 and nuts 5.

In this step, you will use:

Item 4: 9 screws M16 x 45
(dia 5/8" x 1 3/4")

Item 5: 9 nuts M16 (5/8")

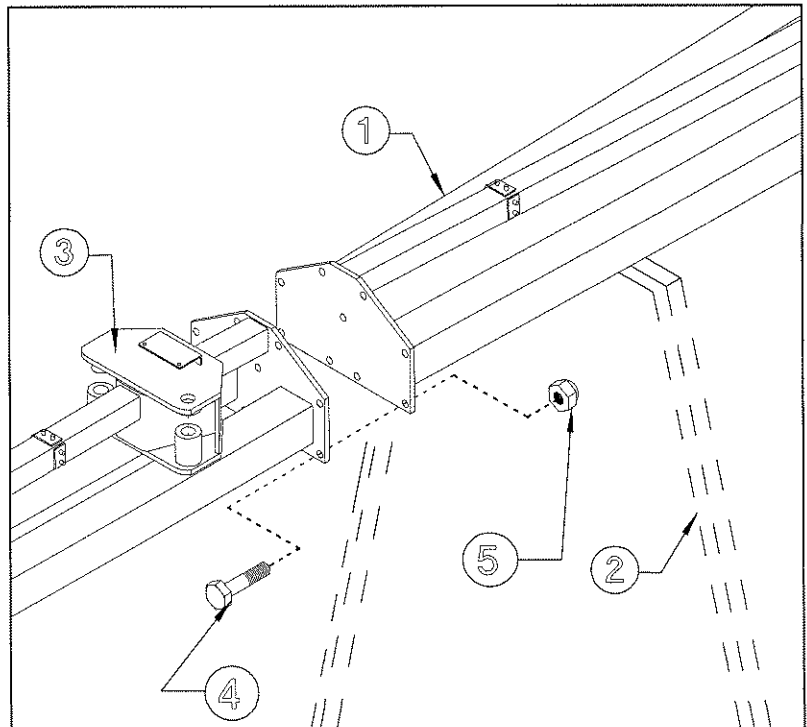

⚠ DANGER !!!

19

The drawbar section 1 must be stable, so it must be held either by a jack or support 2 (weight 240 KG/ 530 LBS).

Attach bar section 3 (weight 100 KG/220 LBS) to drawbar section 1 using screws 4 and nut 5.

In this step, you will use:

Item 4: 9 screws M16 x 45 (5/8" x 1" 3/4)

Item 5: 9 nuts M16 (5/8")

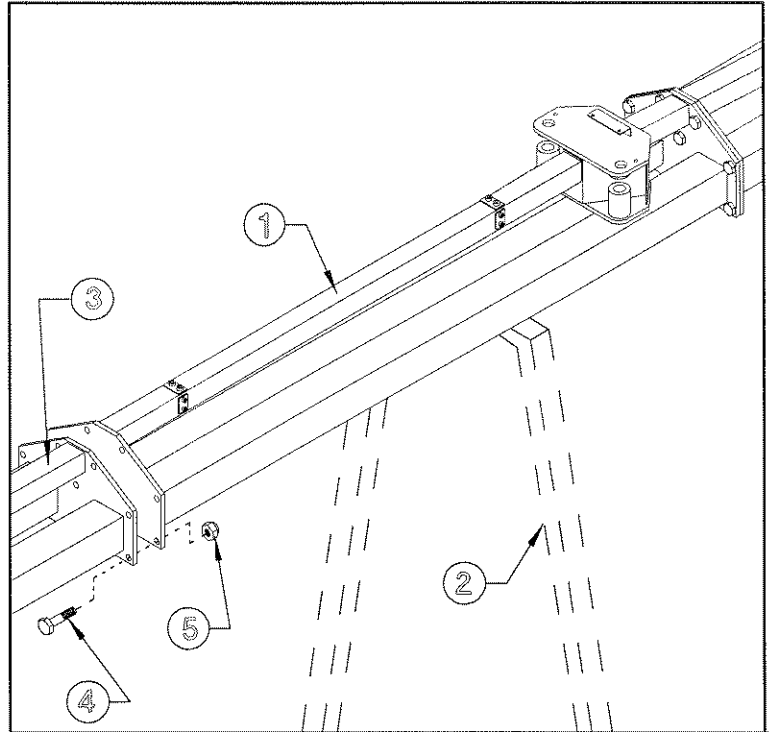

⚠ DANGER !!!

20

The drawbar section 1 must be stable, so it must be held either by a jack or support 2 (weight 340 KG/ 750 LBS).

Attach bar section 3 (weight 115 KG/250 LBS) to drawbar section 1 using screws 4 and nut 5.

In this step, you will use:

Item 4: 9 screws M16 x 45 (5/8" x 1" 3/4)

Item 5: 9 nuts M16 (5/8")

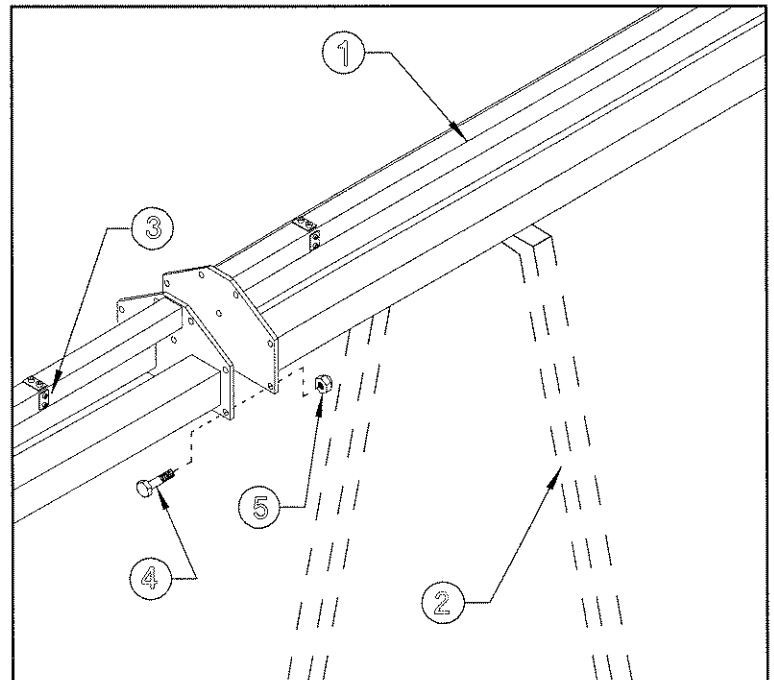

⚠ DANGER !!!

2 1

The drawbar section 1 must be stable, so it must be held either by a jack or support 2 (weight 455 KG/ 1000 LBS).

Attach bar section 3 (weight 65 KG/145 LBS) to drawbar section 1 using screws 4 and nut 5.

In this step, you will use:

Item 4: 6 screws M16 x 45
(5/8" x 1" 3/4)

Item 5: 6 nuts M16 (5/8")

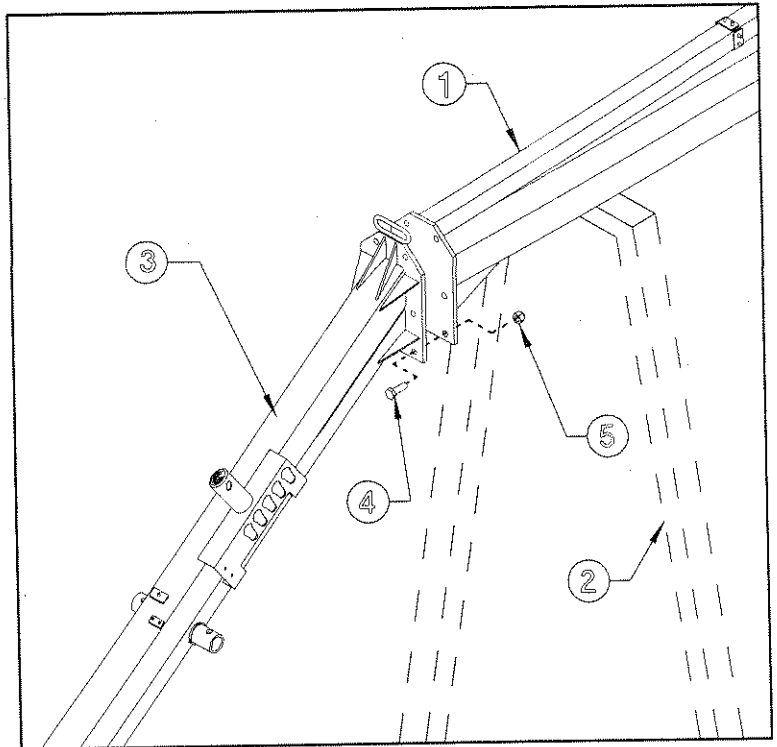

⚠ DANGER !!!

2 2

Attach the parking stand 2 to drawbar 1, fastening it with pin 3 and clip 4.

Insert hitch 5 in the end drawbar 1 and fasten with pins 6, washers 7 and nut 8.

In this step, you will use:

Item 3: 1 pin $\varnothing 15 \times 78$
($\varnothing 19/32" \times 3 1/8"$)

Item 4: 1 clip $\varnothing 3$ ($\varnothing 1/8"$)

Item 6: 2 pins $\varnothing 25 \times 124$
($\varnothing 1" \times 5"$)

Item 7: 2 washers $\varnothing 12-36 \times 2.5$
($\varnothing 15/32"-1 27/64" \times 3/32"$)

Item 8: 2 screws M12 X 20
($15/32" \times 13/16"$)

Note: the transport position of the parking stand 2 is described on page 41.

Hitch 5 should be attached flange "A" towards the top.

To choose which should be used, see page 41.

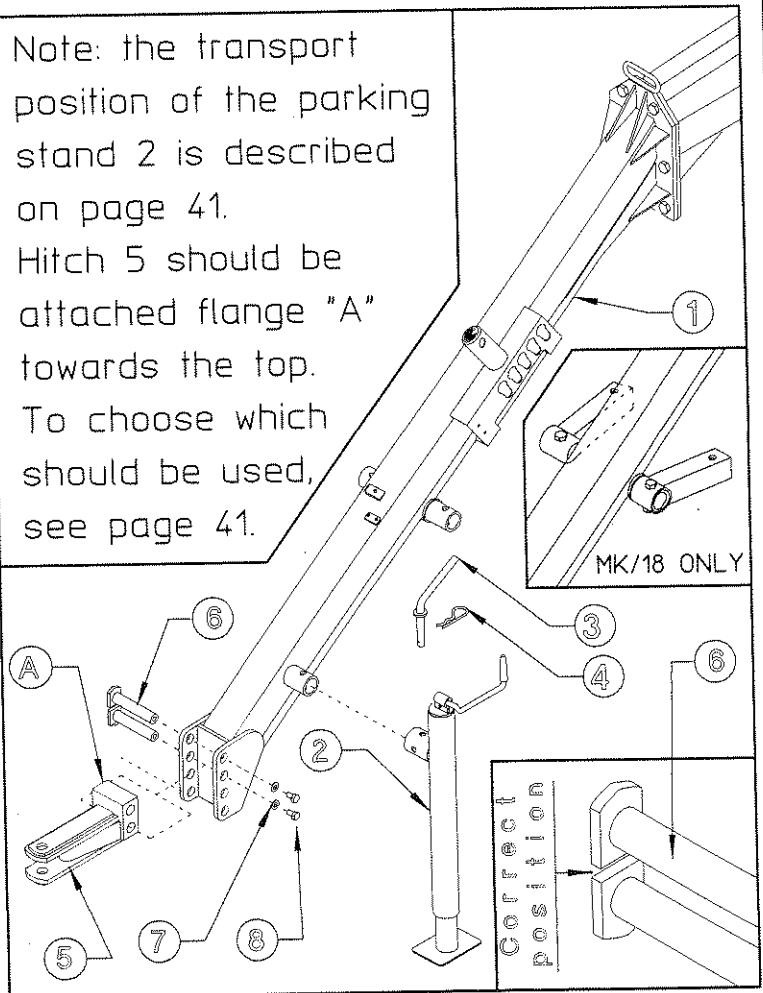

⚠ CAUTION !!

23

Attach arms 3 & 4 (RH-LH) and counterplates 5 to sections 1 & 2 (RH-LH) fastening them with screws 6 and nuts 7. (See diagram "A" for the correct positioning of the parts).

In this step, you will use:
 Item 6: 16 screws M12x140 (15/32" x 5 1/2")
 Item 7: 16 nuts M12 (15/32")

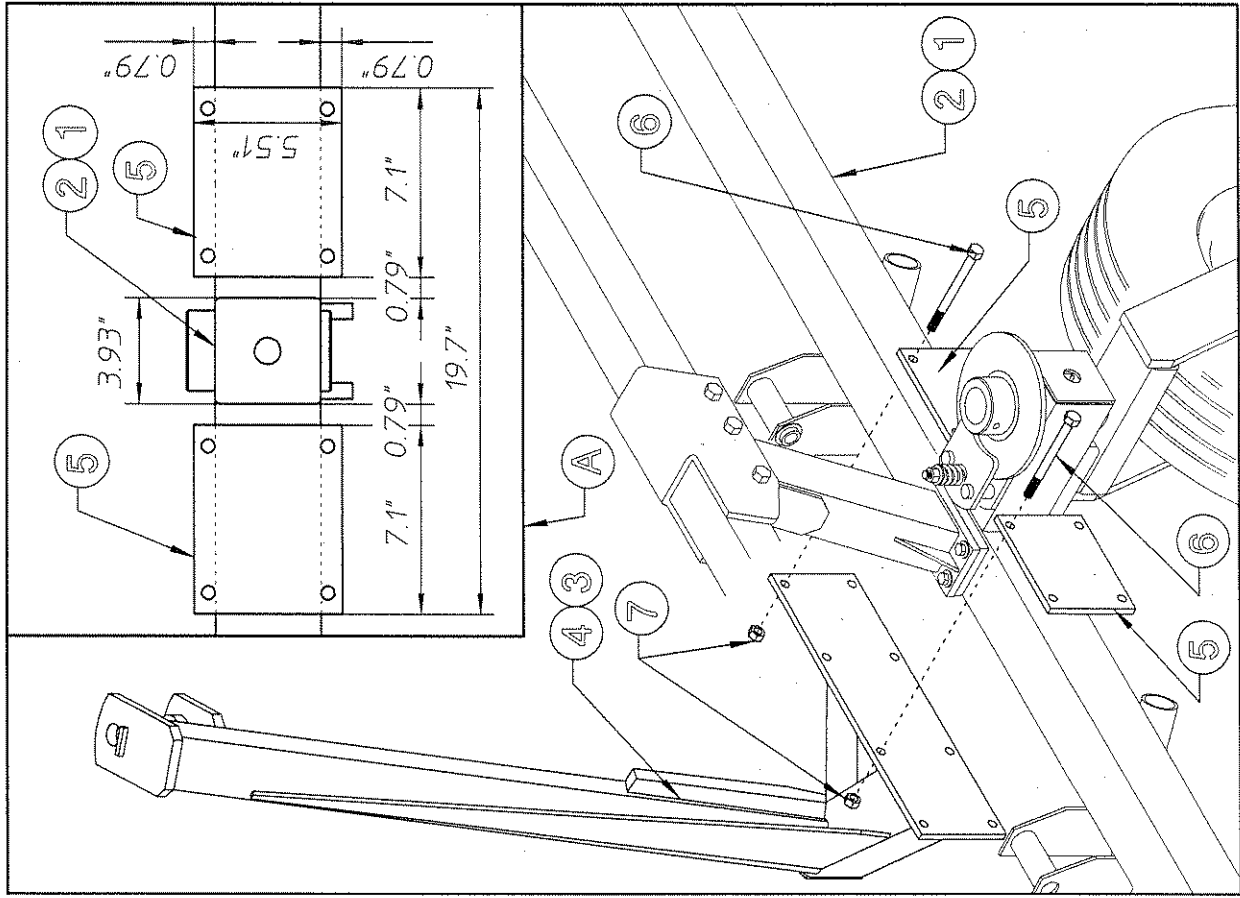

24

You have now reached this stage of the assembly. The machine is now stable, however, caution is still recommended for the remaining assembly step.

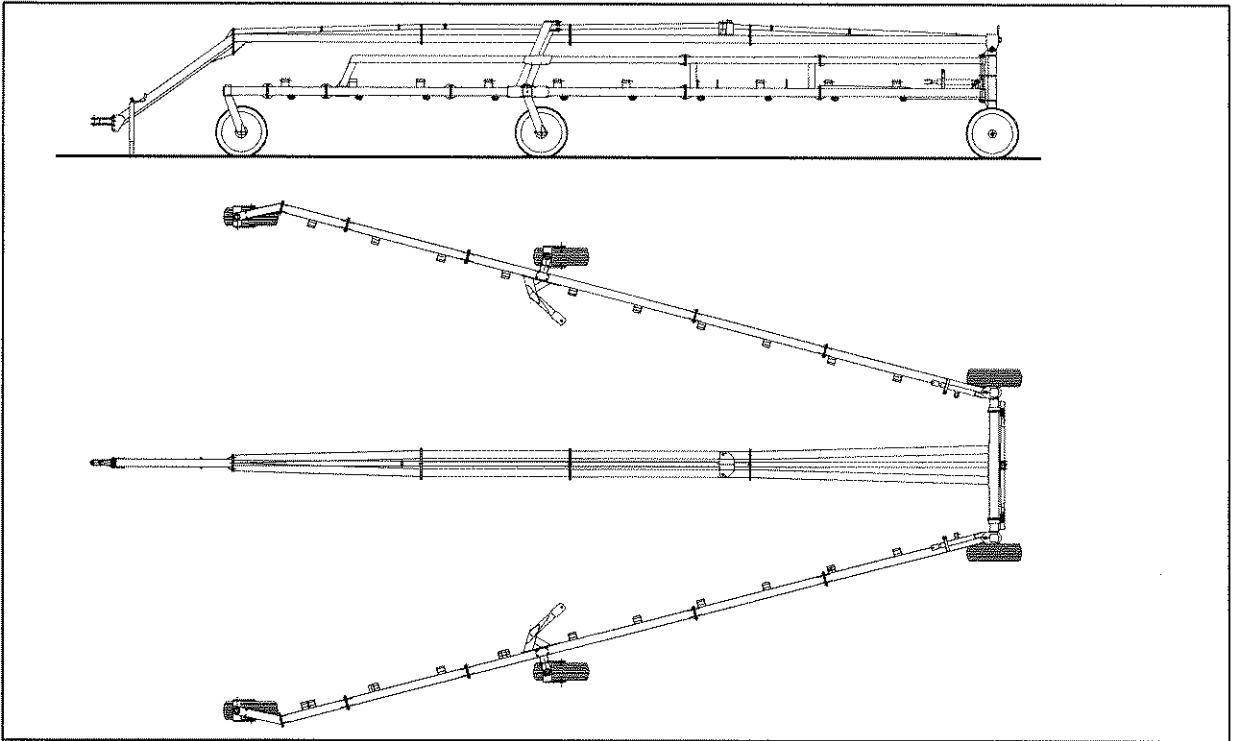

⚠ CAUTION !!

25

Attach grease nipples 1 to the correct holes of supports 2 & 3 (RH-LH).
Connect attachments 4 & 5 (LH -RH) to the forks on the piston end of cylinders 6, fastening them with pins 7 and split pins 8. Insert crank 9 in the correct hole of brackets 2 & 3 (RH-LH).

In this step, you will use:

Item 1: 2 grease nipples M6 (1/4")

Item 7: 2 pins $\varnothing 25 \times 70$ (1" x 2 3/4")

Item 8: 4 split pins $\varnothing 6 \times 35$ (15/64" x 1 3/8")

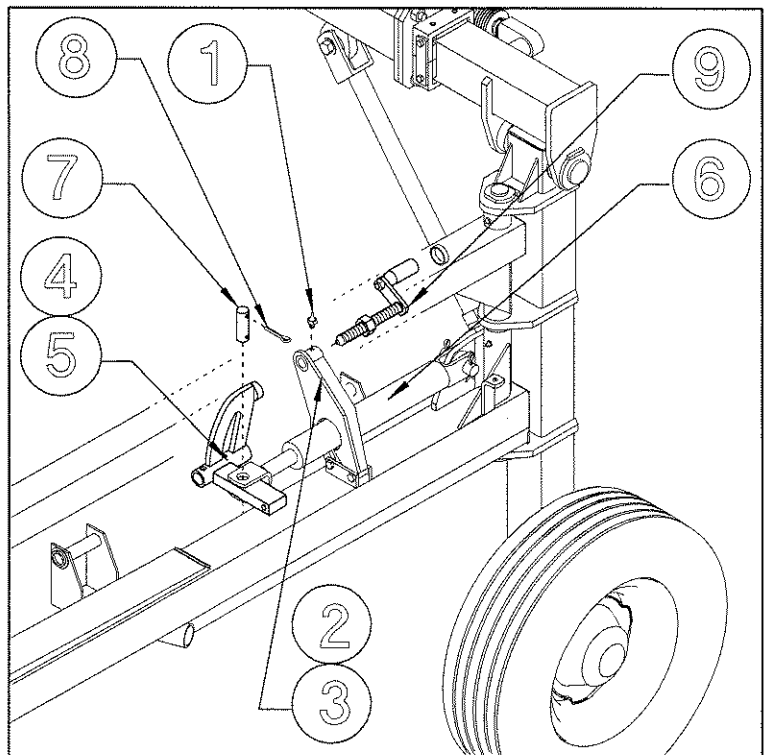

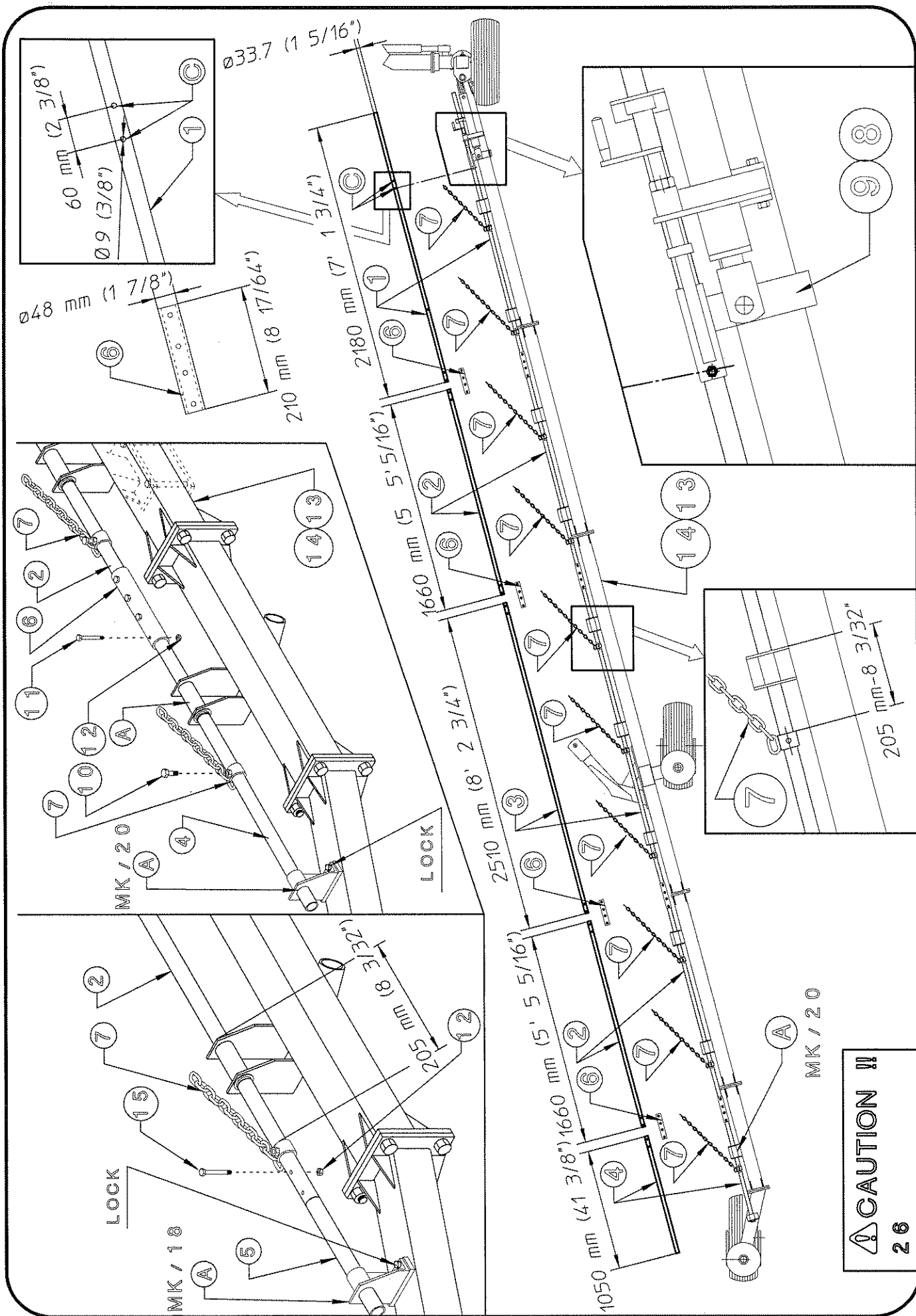

⚠ CAUTION !!
 26

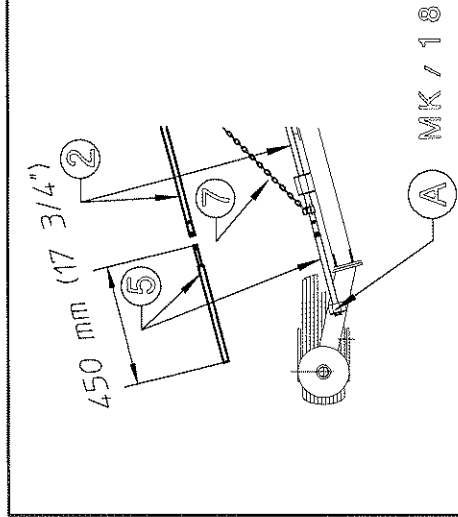

Attach rake wheels lifting pipes 1-2-3-2-4 for MK/20 and 1-2-3-2-5 for MK/20 to the sections of the RH side and LH side (13-14), beginning at point "A". At the same time, the chain attachments 7 should be placed in the positions shown, as well as the connectors 6.

Pipes 1 must also pass through the correct openings of attachments 8 & 9 (RH-LH). At this point connect attachments 8 & 9 to spots "C" on pipes 1 using screws 11 and nuts 12.

Connect pipes 1-2 and 2-3 and 3-2 and 2-4 (for MK/20) and 1-2 and 2-3 and 3-2 and 2-5 (for MK/18 using connectors 6, screws 11-15 and nuts 12. Fasten in the positions shown the chains attachments 7 using screws 10.

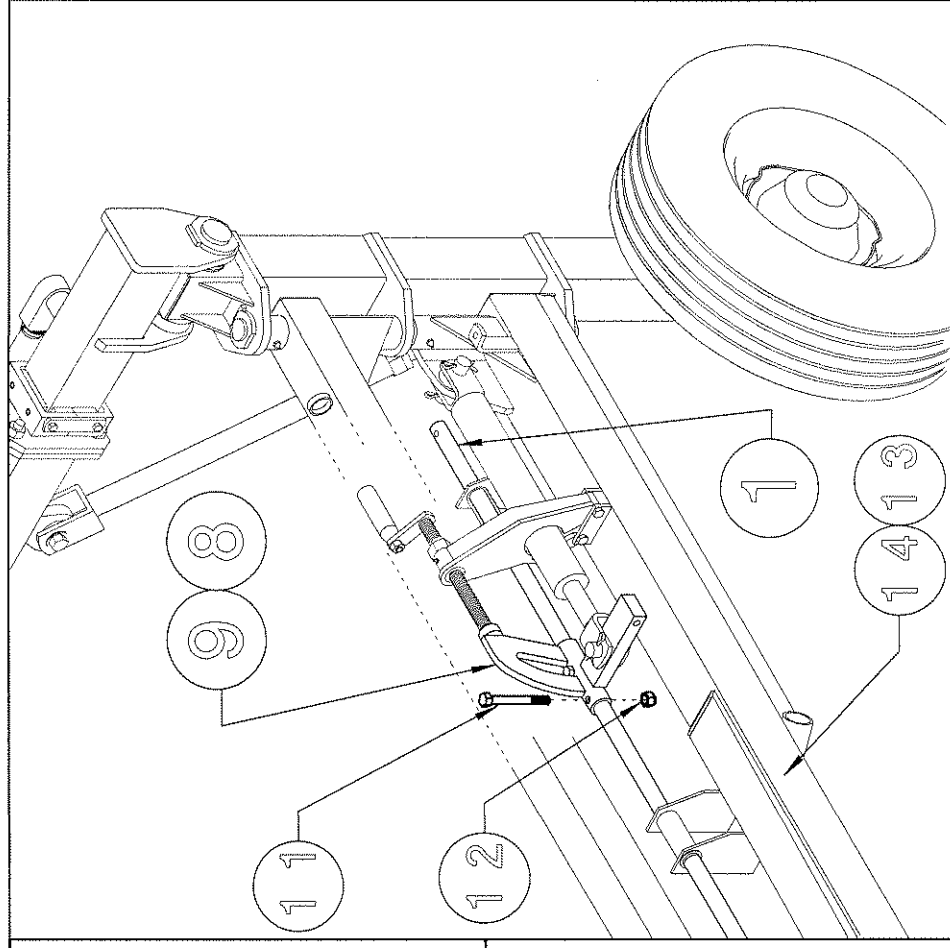

In this step, you will use:

- Item 10: 20/18 screws M10x25 (25/64" x 1")
- Item 11: 36/28 screws M8 x60 (5/16" x 2 3/8")
- Item 12: 36/30 nuts M8 (5/16")
- Item 15: 2 screws M8x45 (5/16" x 1 3/4") (MK/18 only)

CAUTION !!

27

First of all place stay bolts 1 inside springs 2.
 Attach spring 2 with stay bolt 1 into correct hole "A" of the sections 3 & 4 (RH-LH) and attachments 5 & 6 (RH-LH) as shown, fastening the spring-bolt assembly in place with nuts 7.
 Fasten stay bolt 1 with nuts 7 so that they extend 25 mm (1") from attachments 5 & 6.
 Insert pin 8 into correct hole "B" of the sections 3 & 4 and fasten with clip 9.

In this step, you will use:

- Item 7: 4 nuts M10 (25/64")
- Item 8: 2 pins $\varnothing 10 \times 55$ ($\varnothing 25/64" \times 2 \ 5/32"$)
- Item 9: 2 clips $\varnothing 3$ ($\varnothing 1/8"$)

NOTE: FOR CORRECT SETTING OF PINS 8 DURING WORKING AND TRANSPORT POSITIONS SEE PAGES 42 AND 45.

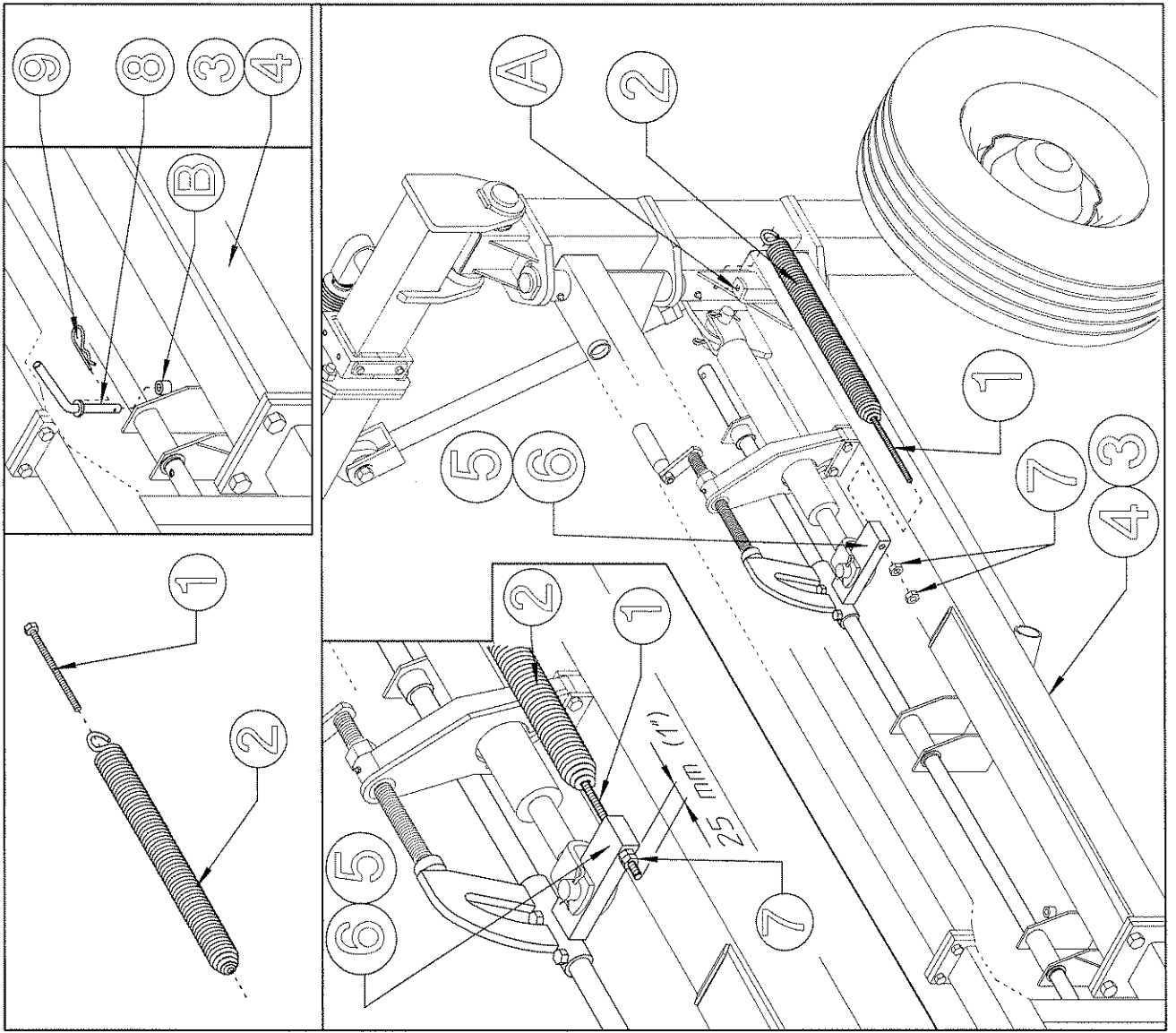

CAUTION !!

28

Attach bushings 1 and grease nipples 2 to rake wheel sections 3 & 4 (RH-LH) as shown.

Attach rake arms 5 & 6 (RH-LH) to correct seats of the sections 3 & 4 and fasten with washers 7 and spring pins 8.

Mount rake wheels 9 & 10 (RH-LH) to rake wheel arms 5 & 6 and fasten with screws 11, grower washers 12 and nuts 13.

In this step, you will use:

- Item 1: 40/36 bushings $\varnothing 35-42 \times 26$ ($\varnothing 1 \frac{3}{8}-1 \frac{11}{16}'' \times 1''$)
- Item 2: 20/18 grease nipples M6x45° ($15/64'' \times 45^\circ$)
- Item 7: 20/18 washers $\varnothing 35-50 \times 5$ ($\varnothing 1 \frac{3}{8}-2'' \times 3/16''$)
- Item 8: 20/18 spring pins $\varnothing 8 \times 50$ ($5/16'' \times 2''$)
- Item 11: 120/108 screws M10x25 ($25/64'' \times 1''$)
- Item 12: 120/108 grower $\varnothing 10.5-17 \times 2.5$ ($\varnothing 27/64''-11/16'' \times 3/16''$)
- Item 13: 120/108 nuts M10 ($25/64''$)

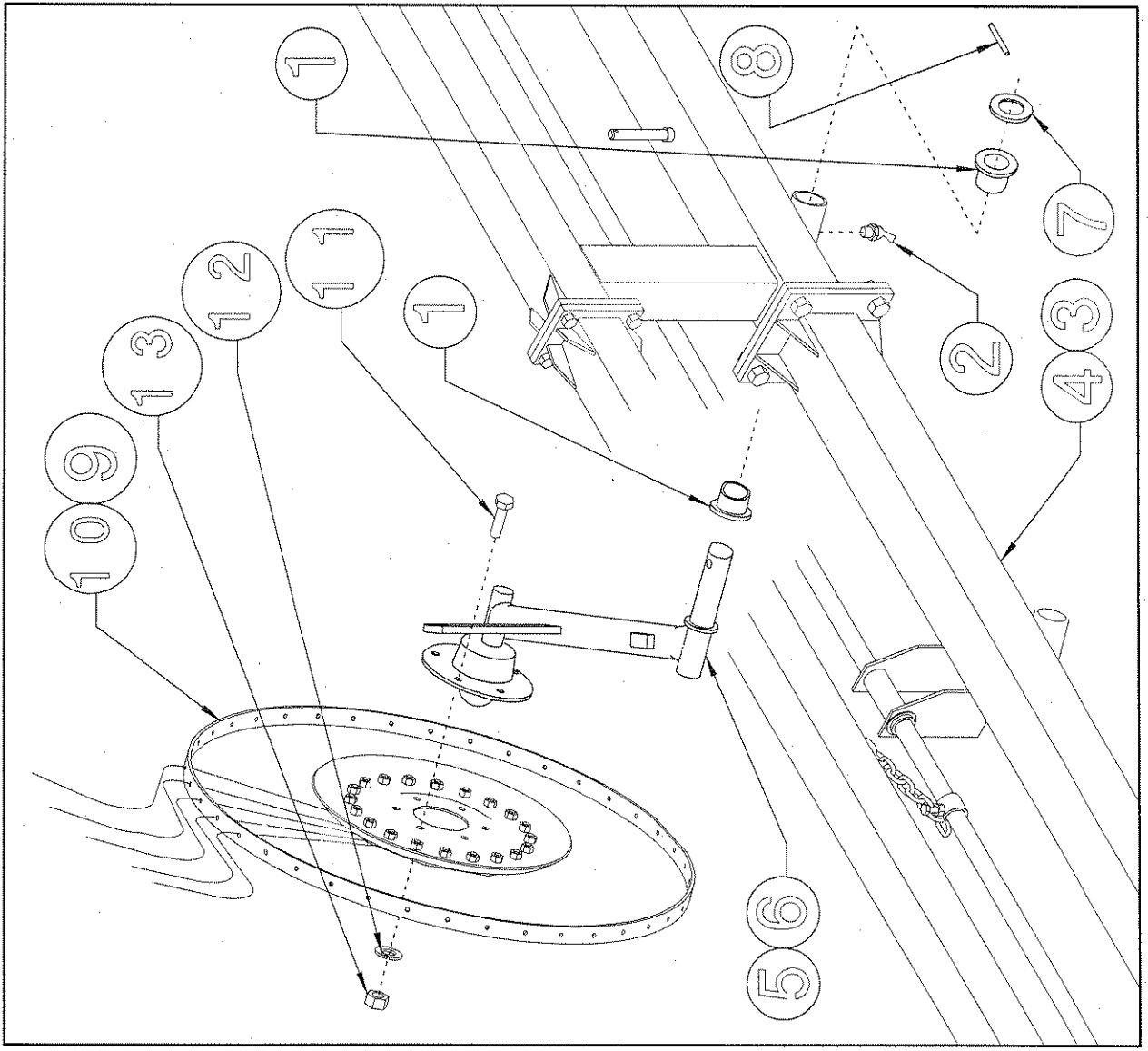

CAUTION !!

27

The spring hook "X" is more closed than spring hook "y".

Insert end "V" of the chain attachment bushing 1 in part "K" of the spring 3, passing it out through the other side. Hook the 9th link of chain 1 on hook "X" of spring 3.

Hook the link "V" and the 24th link of chain 1 (6th from the end) on fork assy 2 and then link it into hole "J" of arms 4 & 5 (RH-LH).

Hook "Y" of spring 3 into hole "Z"

NOTE: That given before is a standard regulation of the chain 1. In picture is also indicated the better position of chain bushing 6 round pipe axis.

In this step, you will use:

Item 3: 20/18 springs $\varnothing 7-56 \times 276$ ($\varnothing 9/32-2$ 13/64" x 10 7/8")

Item 2: 20/18 fork assy M8 (5/16")

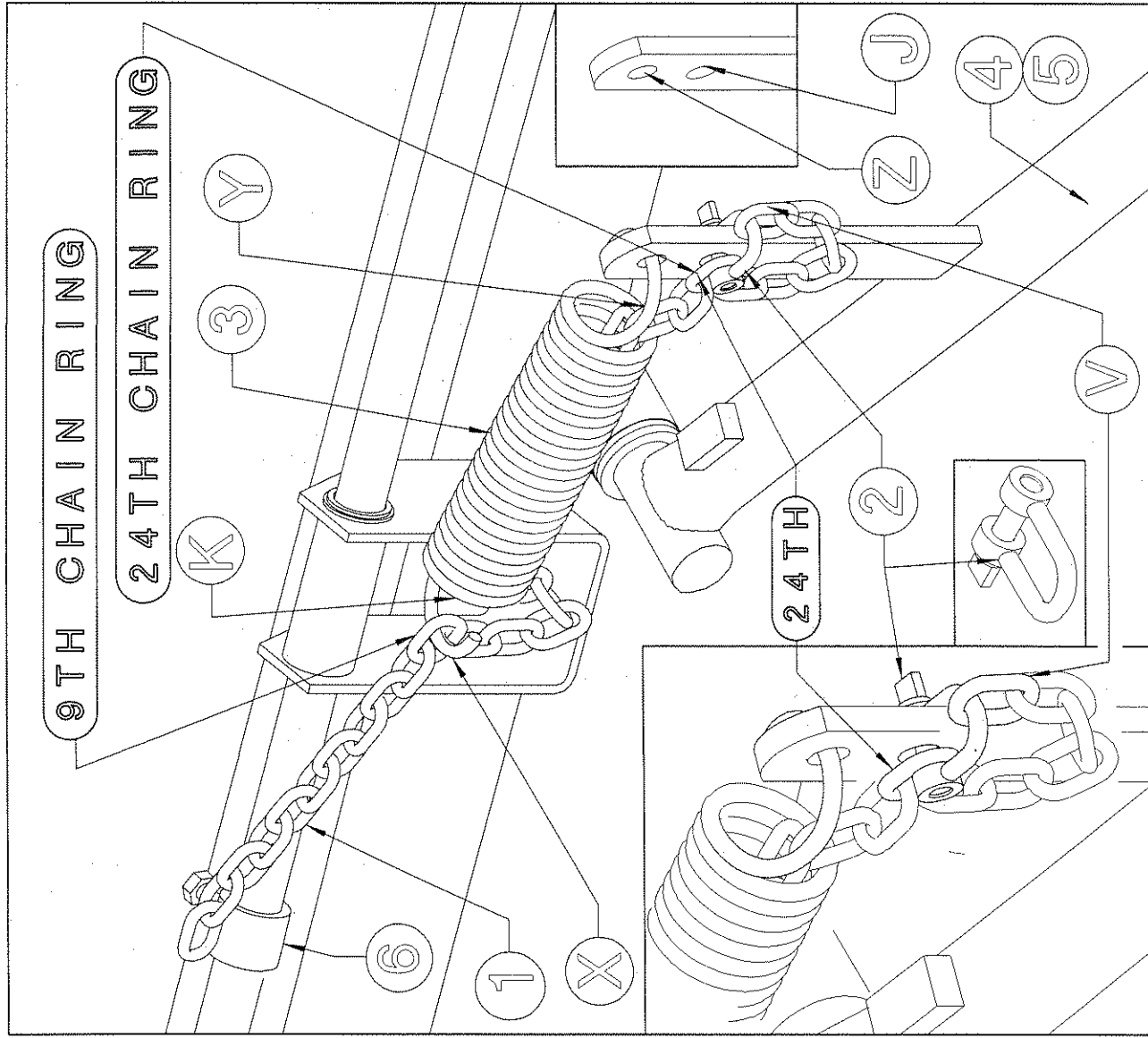

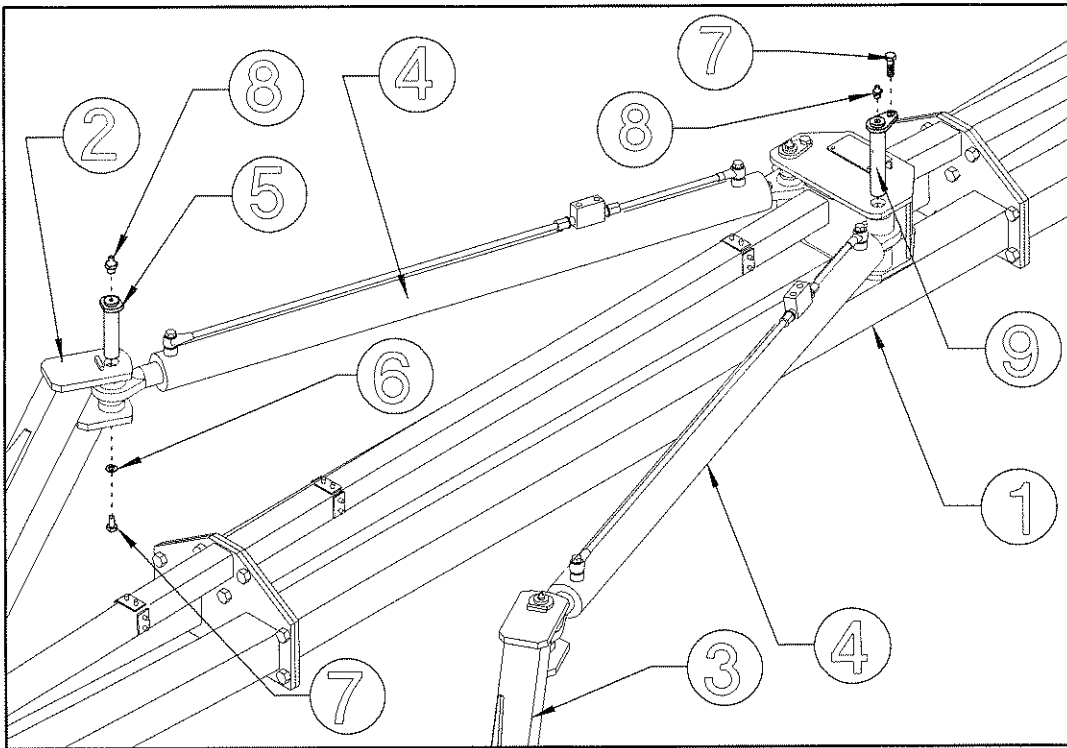

30

! CAUTION !!

Fit cylinders 4 into the correct places on drawbar 1 and fixed arms 2 & 3 (RH-LH). Fasten cylinders 4 to drawbar 1 with pins 9 and screws 7. Attach grease nipples 8 to pins 9. Fasten cylinders 4 to fixed arms 2 & 3 (RH-LH) with pins 5, washers 6 and screws 7. Attach grease nipples 8 to pins 5.

In this step, you will use:

- Item 5: 2 pins $\varnothing 30 \times 122$
($\varnothing 1 \frac{3}{16}'' \times 4 \frac{13}{16}''$)
- Item 6: 2 washers $\varnothing 12-40 \times 4$
($\varnothing 15/32'' - 1 \frac{9}{16}'' \times 5/32''$)
- Item 7: 4 screws M12 x 20
($15/32'' \times 13/16''$)
- Item 8: 4 grease nipples M8 ($15/16''$)
- Item 9: 2 pins $\varnothing 30 \times 162$
($\varnothing 1 \frac{3}{16}'' \times 6 \frac{3}{8}''$)

31

Fit the flow divider 1 and the hose collar plate 2 to support "A" on the drawbar. Fasten in place with screws 3 and nuts 4.

In this step, you will use:

- Item 3: 2 screws M6x60
($15/64'' \times 2 \frac{3}{8}''$)
- Item 6: 2 nuts M6 ($15/64''$)

Note: For hydraulic rear opening kit assembling see page 47

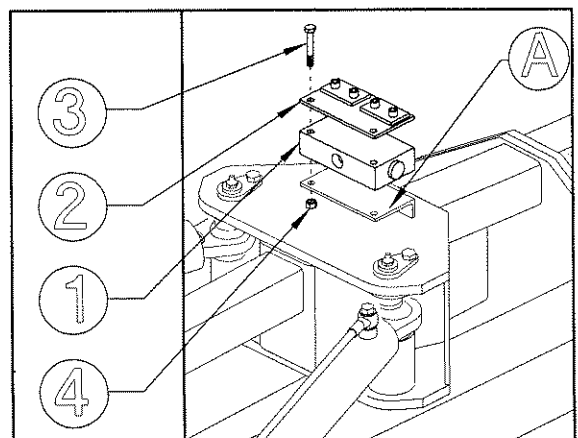

⚠ CAUTION !!

3 2

Attach the eye hose 1 to hole "A" of the cylinder valve and fasten it with washers 2 and fitting 3. Attach washer 2 and nipple 5 to the rear of flow

divider 4. Connect the curved end of hose 1 to nipple 5.

In this step, you will use:

Item 1: 2 hoses (3/8"), length 720 (3/8" x 2' 4 21/64")

Item 2: 6 copper washers 3/8"

Item 3: 2 screws 3/8"

Item 5: 2 nipples 3/8" - 3/8"

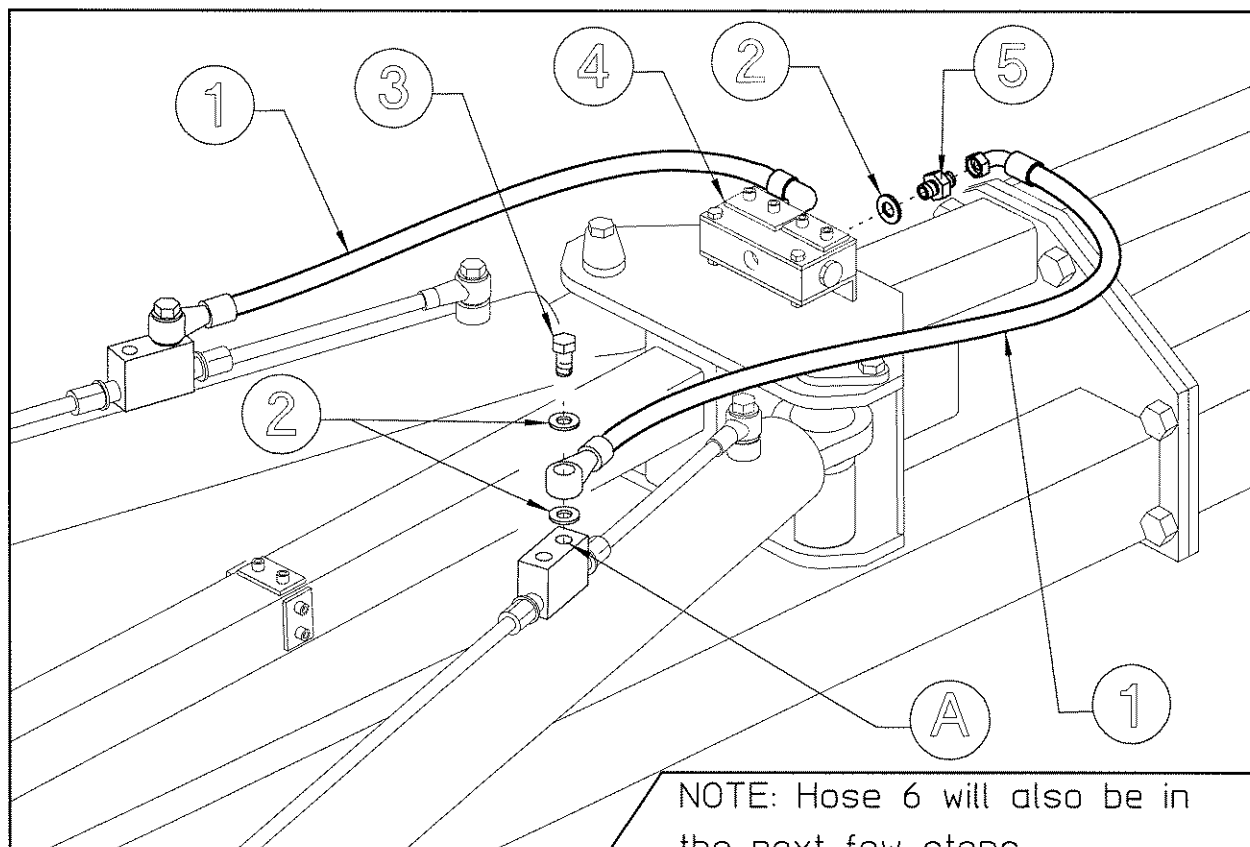

NOTE: Hose 6 will also be in the next few steps.

⚠ CAUTION !!

3 3

Attach washers 2 and nipples 3 to cylinders 1. Connect the curved end of hoses 4 to nipples 3. Pass hoses 4 through rings "A"- "B"- "C" and connect to "T" connector 5 at the center of the machine. Connect hose 6 to "T" connector 5 and secure in place with collars 7 and screws 8.

In this step, you will use:

Item 2: 2 copper washers 3/8"

Item 3: 2 nipples 3/8" - 3/8"

Item 4: 2 hoses (3/8") length 2060 (3/8" x 6' 9")

Item 5: 1 male T connector 3/8"

Item 6: 1 hoses (3/8") length 7720 (3/8" x 25' 4")

Item 7: 6 hose collars $\varnothing 18$ ($\varnothing 45/64$ ")

Item 8: 6 hexagon socket head cap screws M6 x 25 (15/64" x 1")

⚠ CAUTION !!

33

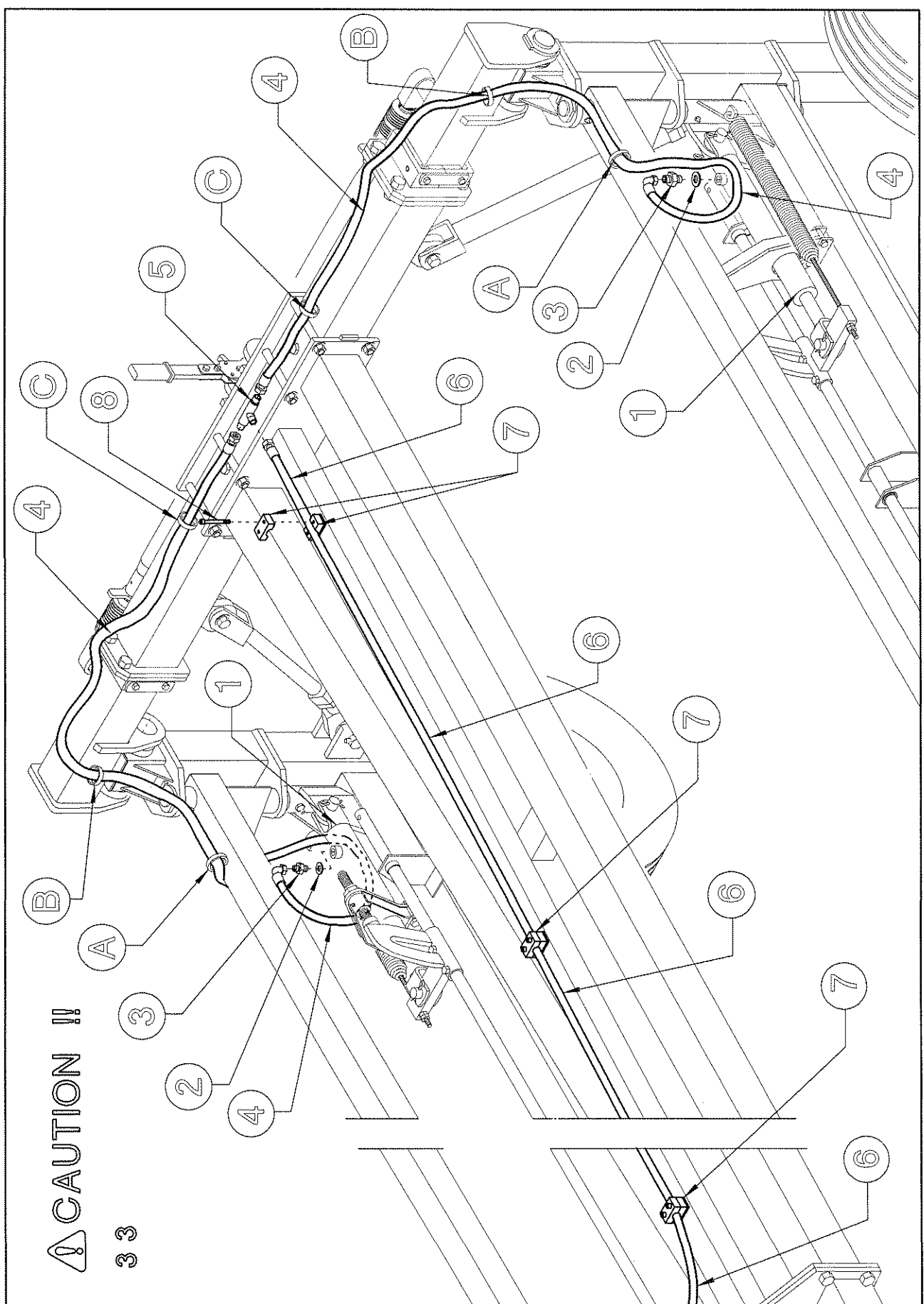

⚠ CAUTION !!

3 4

Continue to secure hose 6 using collars 1 and screws 2.

Attach washer 3 and nipple 4 to hole "A" in cylinder valve.

Connect the curved end of hose 5 to nipple 4.

Join hoses 5 to T connector 7 at the center of the machine.

Hose 6 will also be in the next few steps.

In this step, you will use:

Item 1: 4 hose collars $\varnothing 18$ ($\varnothing 45/64$ ")

Item 2: 4 hexagon socket head cap screws M6x25 ($15/64$ "x 1")

Item 3: 2 copper washers $3/8$ "

Item 4: 2 nipples $3/8$ " - $3/8$ "

Item 5: 2 hoses ($3/8$ " lenth 750 ($3/8$ " x 2' 5" $1/2$))

Item 6: see preceding step.

Item 7: 1 male-female "T" connector $3/8$ ".

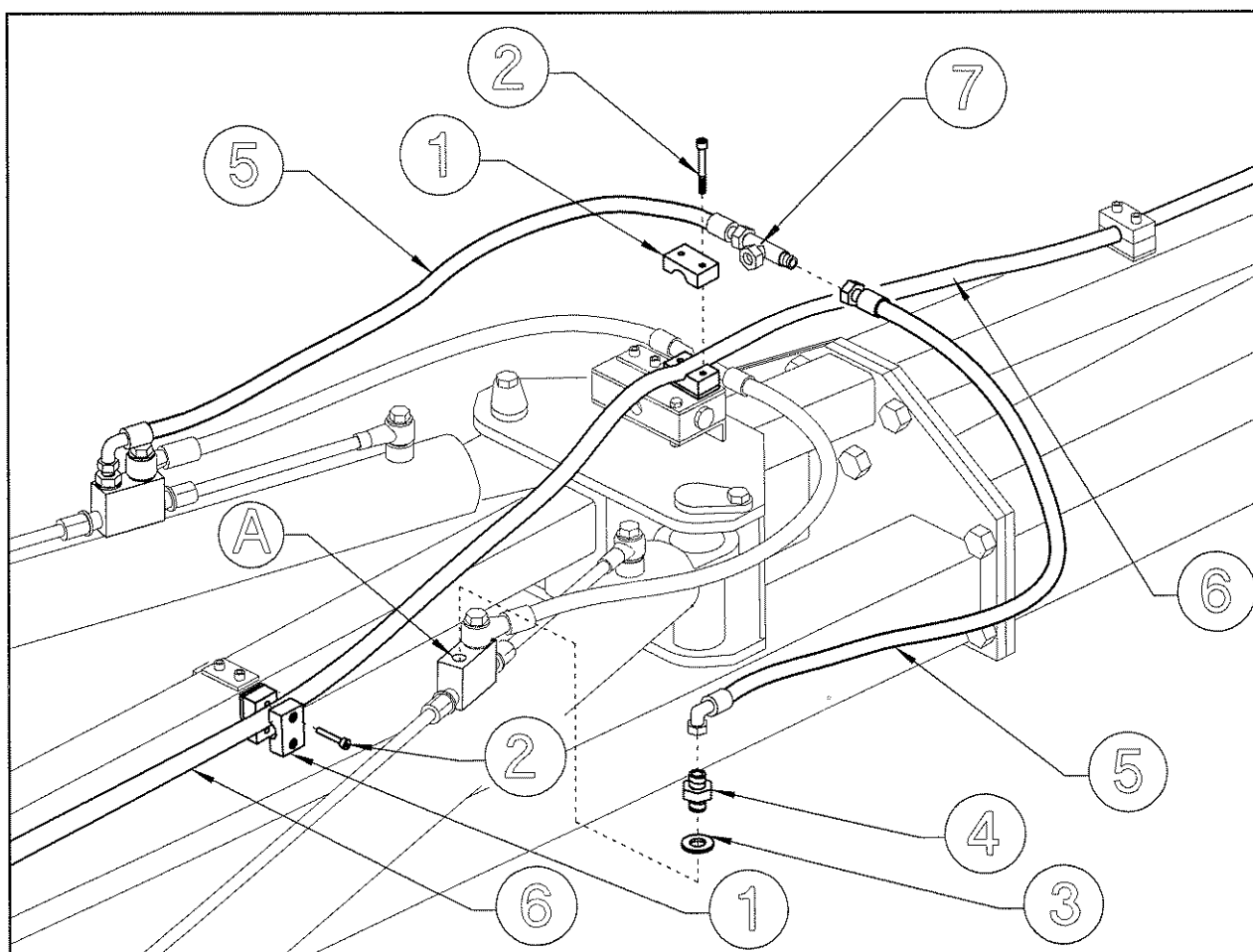

⚠ CAUTION !!

3 5

Screw nipple 1 into hole "A" of the T connector. Screw hose 2 onto nipple 1. Secure hose 2 in place with collars 4 and screws 5. Screw nipple 1 and washer 7 into hole "B" of the flow divider.

Screw hose 3 onto nipple 1 and secure in place with collars 4 and screws 5.

NOTE: Hoses 2-3 will also be in the next few step.

In this step, you will use:

Item 1: 2 nipples 3/8" - 1/2"

Item 2: 1 hose (1/2") length 9630 (1/2" x 31' 7")

Item 3: 1 hose (1/2") length 9480 (1/2" x 31' 1")

Item 4: 6 hose collars $\varnothing 22$ ($\varnothing 7/8$ ")

Item 5: 6 hexagon socket head cap screws M6 x 30 (15/64" x 1 3/16")

Item 7: 1 copper washer 3/8"

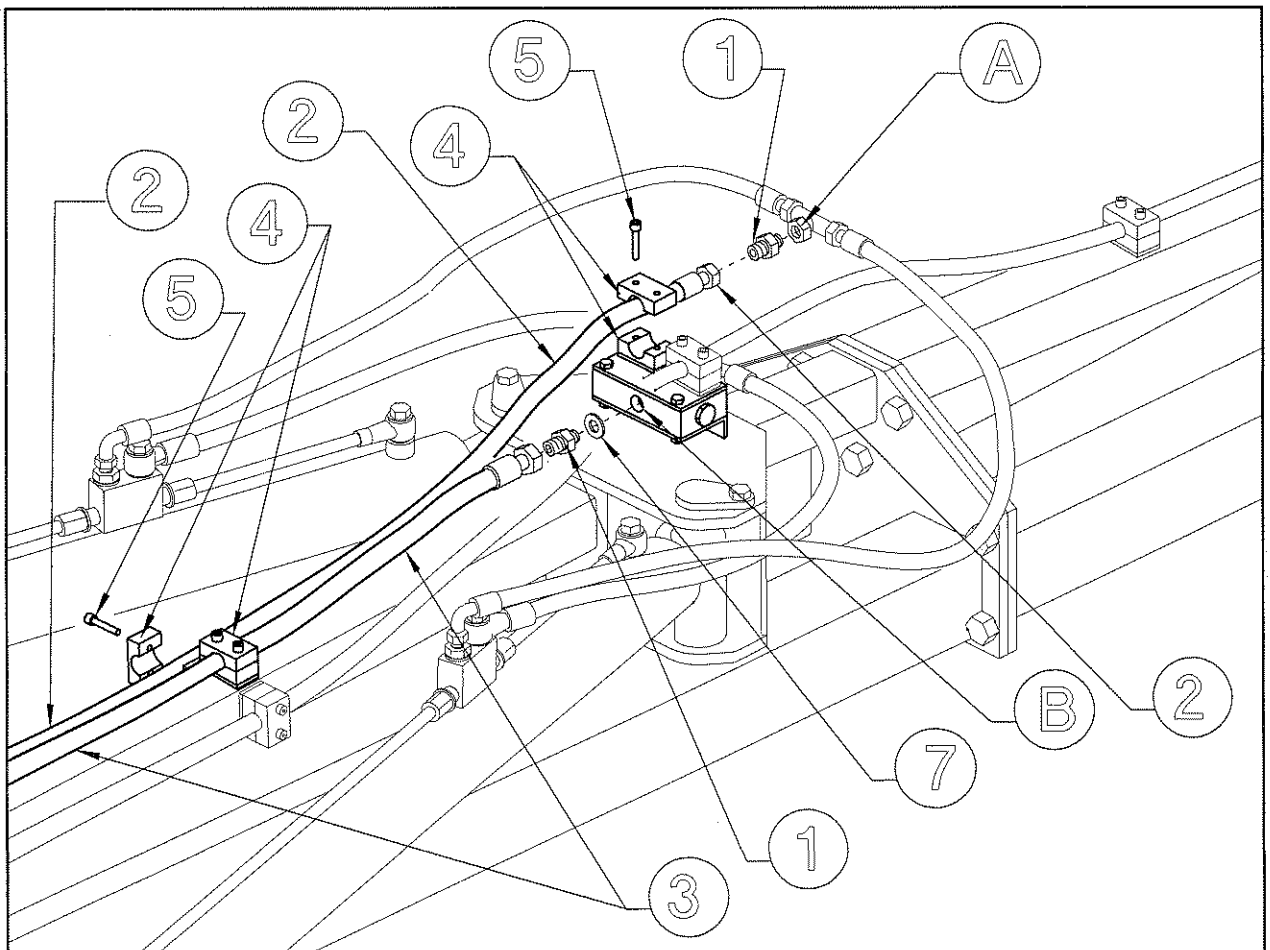

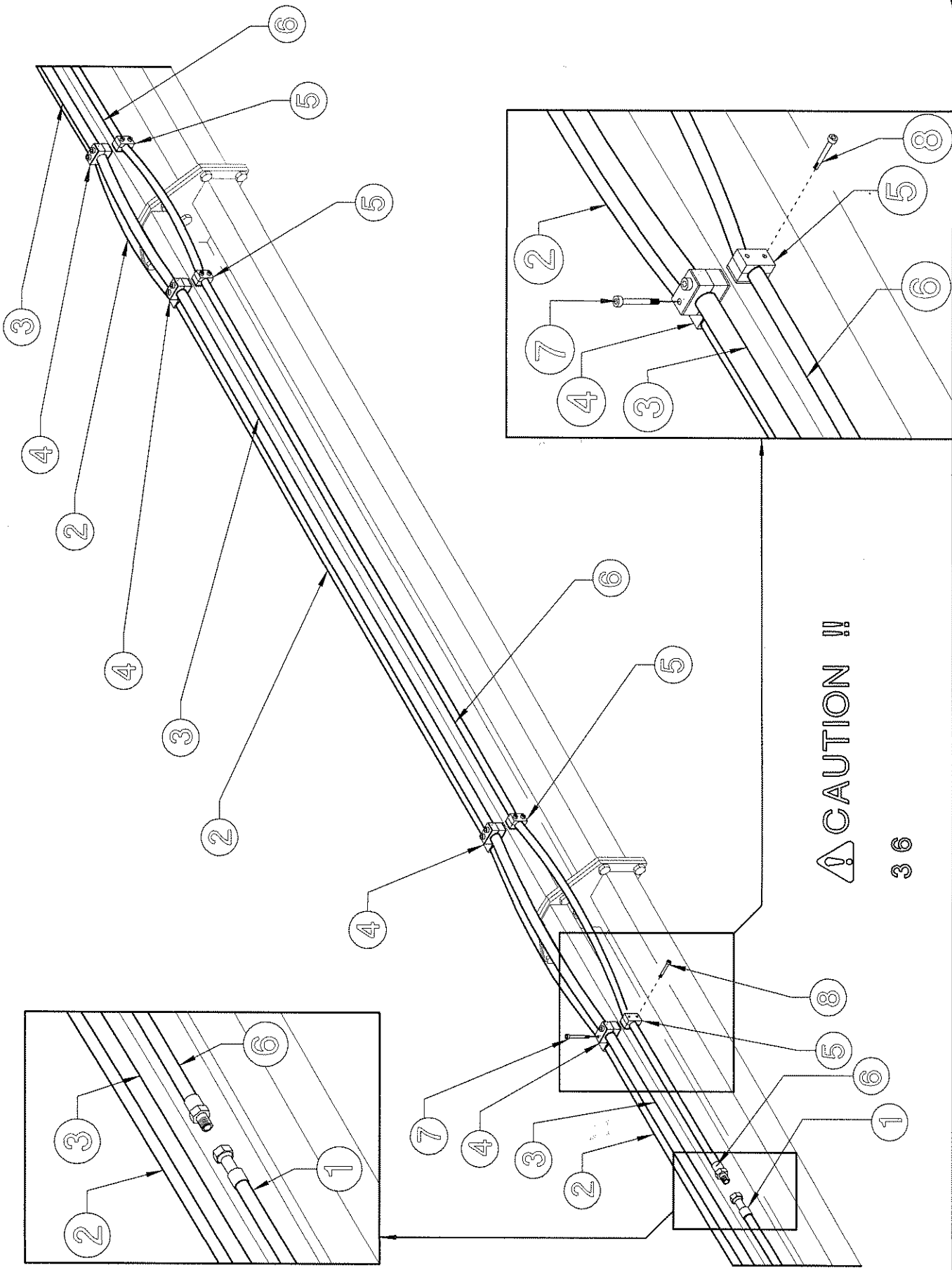

⚠ CAUTION !!

⚠ CAUTION !!

36

Continue to secure hose 6 using collars 5 and screws 8.

Continue to secure hoses 2-3 using collars 4 and screws 7.

Connect the hose 6 with the hose 1.

NOTE: Hoses 1-2-3 will also be in the next few steps.

In this step, you will use:

Item 1: 1 hose (3/8") length 4960 (3/8" x 16' 3")

Item 2: see preceding step

Item 3: see preceding step

Item 4: 16 hose collars $\emptyset 22$ ($\emptyset 7/8"$)

Item 5: 8 hose collars $\emptyset 18$ ($\emptyset 45/64"$)

Item 6: see preceding step

Item 7: 16 hexagon socket head cap screws M6x30 (15/64" x 1 3/16")

Item 8: 8 hexagon socket head cap screws M6x25 (15/64" x 1")

CAUTION !!

37

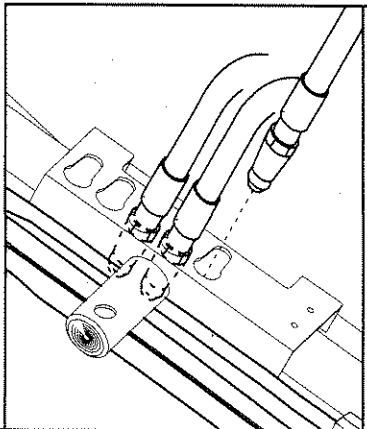

Hoses position when the machine is standing in the parking position

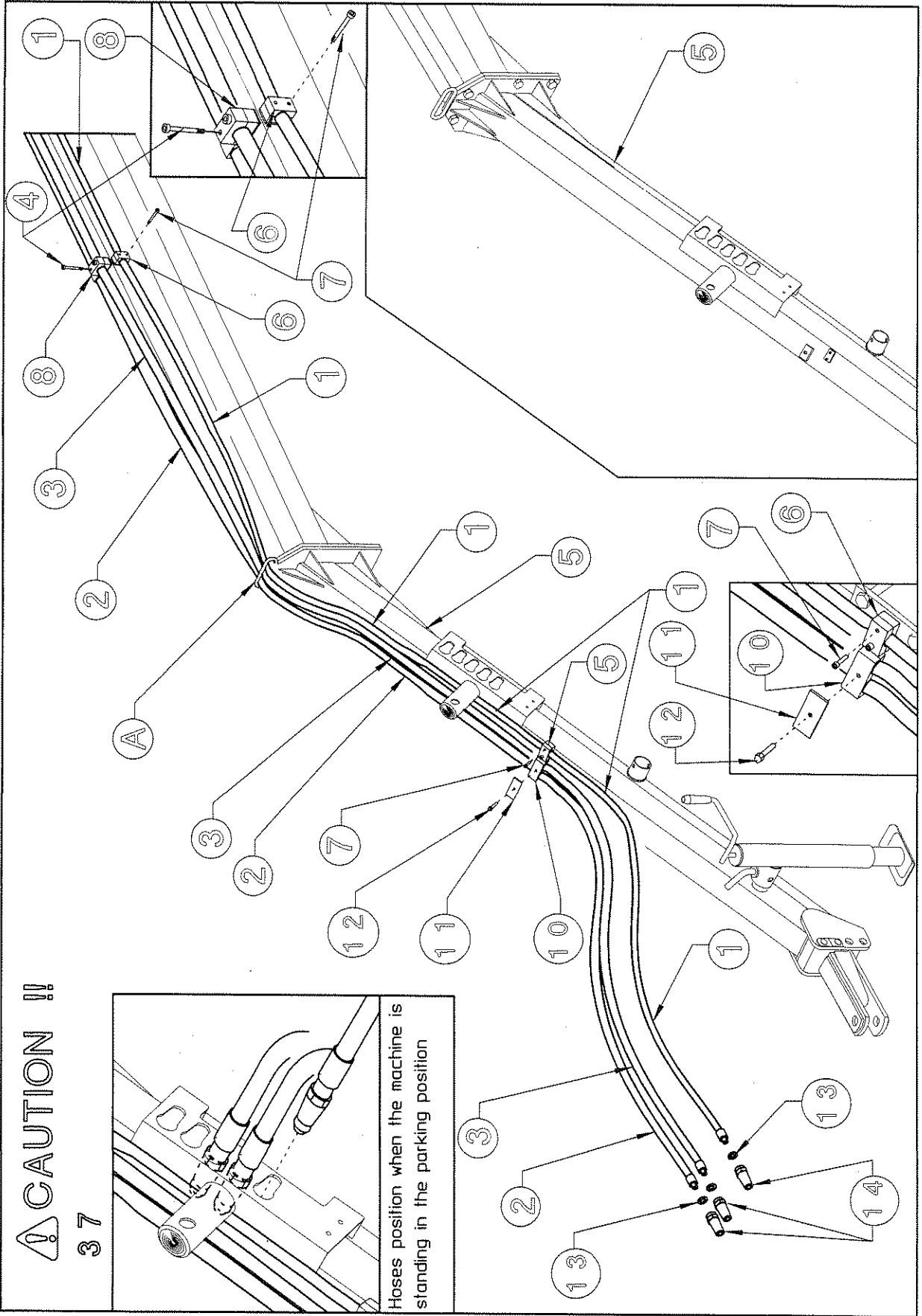

⚠ CAUTION !!

37

Pass hoses 1-2-3 through loop "A" on drawbar 5.
Secure hose 1 in the correct places with hose collars 6 and screws 7. Secure hoses 2-3 in the correct places with hose collars 8, screw 4, double hose collars 10, plate 11 and screws 12. Attach washers 13 and quick-release couplings 14 to the end of hoses 1-2-3.

In this step, you will use:

- Item 1: see preceding step
- Item 2: see preceding step
- Item 3: see preceding step
- Item 4: 4 hexagon socket head cap screws M6 x 30 (15/64" x 1 3/16").
- Item 6: 4 hose collars $\emptyset 18$ ($\emptyset 15/64$ ")
- Item 7: 4 hexagon socket head cap screws M6 x 25 (15/64" x 1")
- Item 8: 4 hose collars $\emptyset 22$ ($\emptyset 7/8$ ")
- Item 10: 2 double hose collars $\emptyset 22$ ($\emptyset 7/8$ ")
- Item 12: 2 screws M8 x 45 (5/16" x 1 3/4")
- Item 13: 3 copper washers 1/2"
- Item 14: 3 quick-release coupling 1/2"

MAINTENANCE POINTS

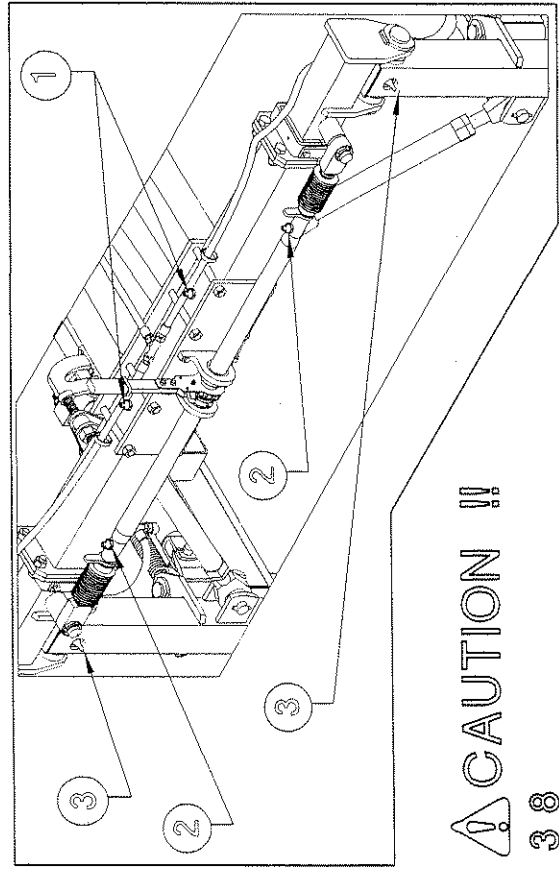
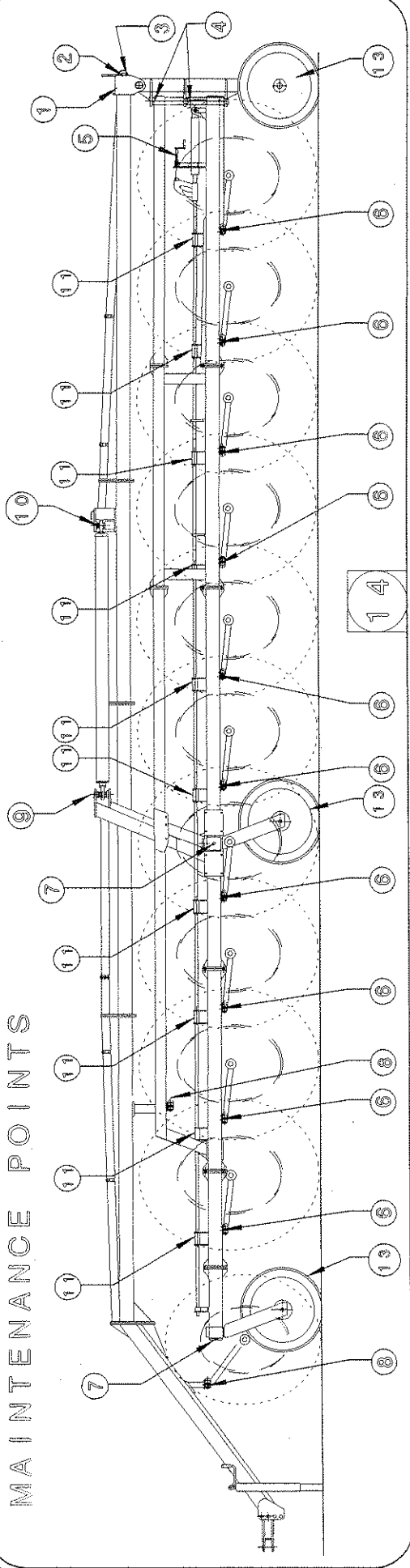

CAUTION !!

38

At this point, the machine is completely assembled. Before testing for operation, it is necessary to lubricate and check the movement of all parts. This diagram gives the maintenance program, to be carried out in its entirety the first time, and subsequently according to the schedule as shown.

ITEM	Q.ty	DESCRIPTION	OPERATION	EVERY x HOURS
1	2	Fixed cross member	Lubricate	A
2	2	Ratchet link	"	A
3	2	Rear wheel support	"	25
4	4	Rake wheel section joints	"	8
5	2	Crank screws	"	A
6	20/18	Rake wheel bracket joints	"	25
7	4	Wheel support joints	"	8
8	2	Small rake wheel joints (optional)	"	25
9	2	Opening cylinder head joints	"	16
10	2	Opening cylinder foot joints	"	16
11	20/18	Pipe supports	"	25
12	6	Tires	Check pressure	A
13	---	General checking of bolts, security pins and split pins to be carried out initially after the first 8 hours of use. Subsequently every 50 hours and whenever the machine is laid up for extended periods.		

A = EVERY TIME THE PART IS USED

GENERAL INSTRUCTIONS FOR USE

⚠ DANGER !!!

39

To connect the machine to the tractor, first it is necessary to raise or lower parking stand 1 so that drawbar 2 is parallel to the ground. Back the tractor up to the machine and look to see if hitch 3 is aligned with tractor hitch 4. If hitch 3 is much higher or lower than tractor hitch 4, it is necessary to change the position of hitch 3 by choosing the

holes in plate 5 which give the best alignment.

At this point connect hitch 3 to tractor hitch 4 using a suitable pin.

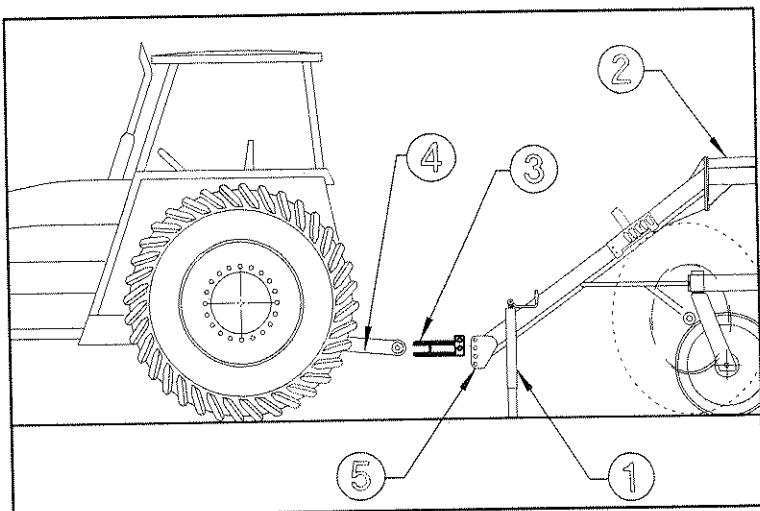

⚠ CAUTION !!

40

During transport and working the parking stand 1 must be shifted from position "A" to position "B".

This is done by removing clip 2 and pin 3 and moving stand 1 out of the parking position.

Fasten parking stand 1 into the transport position using pin 3 and clip 2.

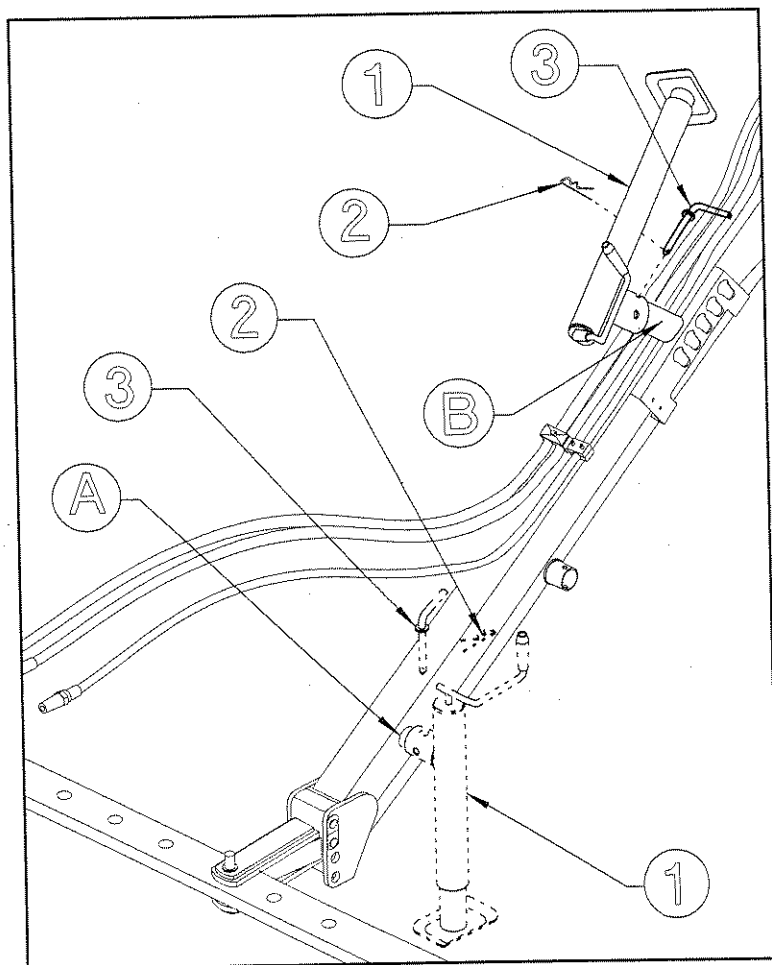

⚠ DANGER !!!

4 1

At this point quick-release couplings of hoses 1-2-3 should be attached to the relative tractor couplings 4-5-6. The movements of the machine are now controlled by operating levers A-B.

Hoses 1-2, connected to tractor couplings 4-5, control the cylinders for opening the machine.

Hose 3, connected to tractor coupling 6, controls the cylinders for lifting the rake wheel.

It is recommended that all movements be repeated a few times to eliminate air from the system.

The machine is now ready for operation.

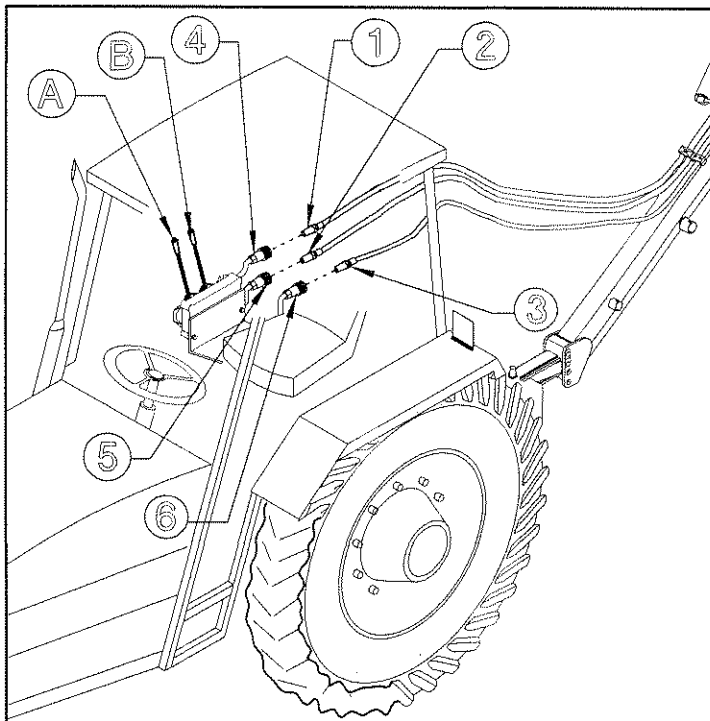

⚠ CAUTION !!

4 2

During transport it is necessary to move pin 1 and clip 2 from position "A" to position "B".

This removes the load from the rake wheel lifting cylinders.

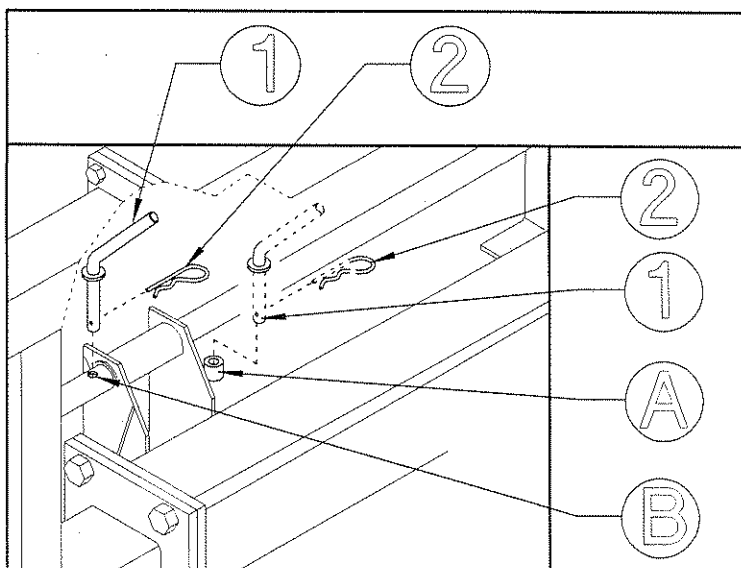

⚠ DANGER !!!

4 3

At this point it is necessary to attach the transport arms. Insert arm 1 in arm 2 and lock in place with pin 3 and clip 4. The transport arm assembly is then attached by placing the fork of arm 1 on attachment A of the draw-

bar and the fork of arm 2 on the wheel support. Fasten with pins 3 and clips 4.

In this step, you will use:
Item 3: 6 pins $\varnothing 15 \times 87$
($\varnothing 19/32" \times 3 27/64"$)
Item 4: 6 clips $\varnothing 3$ ($\varnothing 1/8"$)

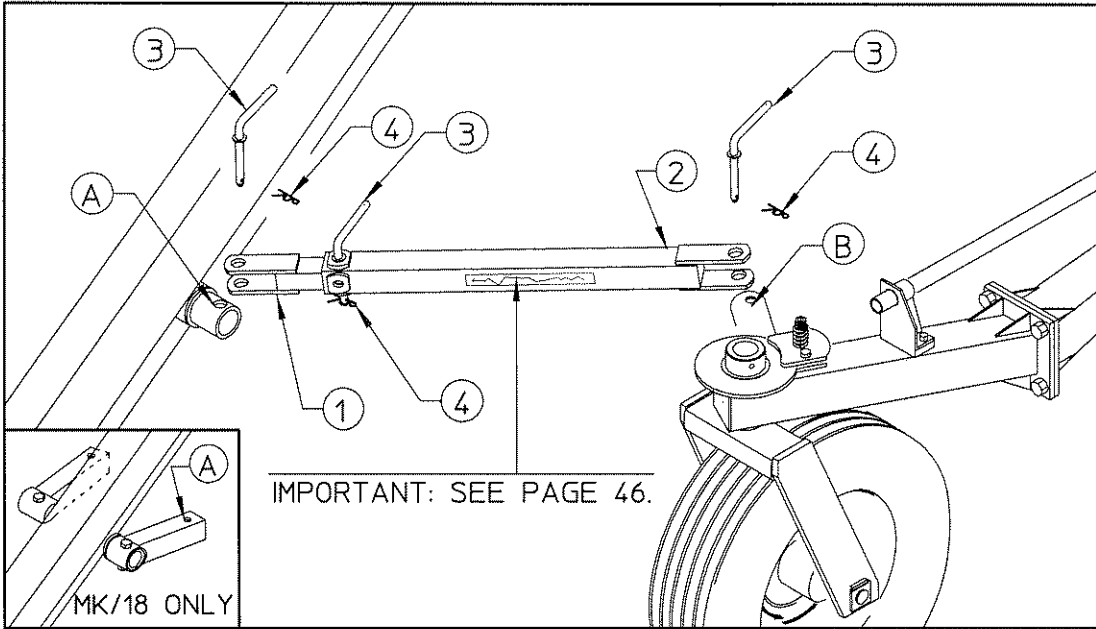

4 4 This is the assembly diagram for the MK20 and MK18. The row of holes on the arms is for when the rear axle is widened. Under no circumstances should the cylinders be operated while the transport arms are attached. The machine is now to be transported to the work site.

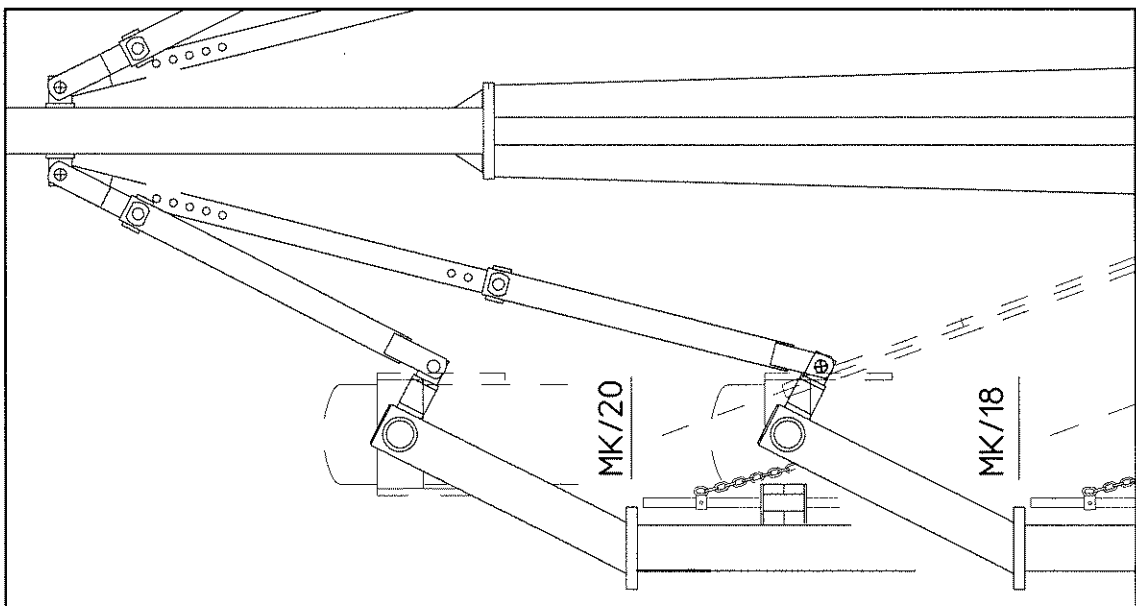

GENERAL INSTRUCTIONS FOR FIELD USE



CAUTION !!

4 5

The first thing to be done in the field is to remove transport arm 1-2, replacing pins 3 in holes A-B and fastening them with clips 4. The transport arm 1-2 assemblies are to be placed over pins C-D on

the rake wheel sections as shown. Fasten the transport arm to pins C-D with clips 5.

In this step, you will use:
Item 5: 4 clips d.3 (1/8")

IMPORTANT I

BEFORE STARTING RAKING OPERATION MAKE SURE THAT THE TRANSPORT LOCK ARMS HAVE BEEN REMOVED FROM THE TRANSPORT POSITION AND SET IN WORKING POSITION.

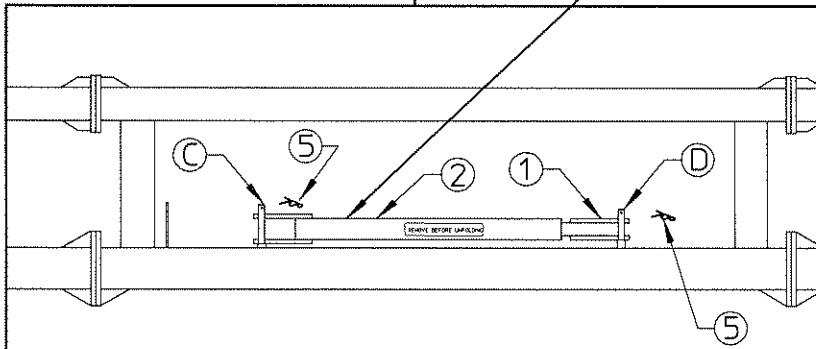
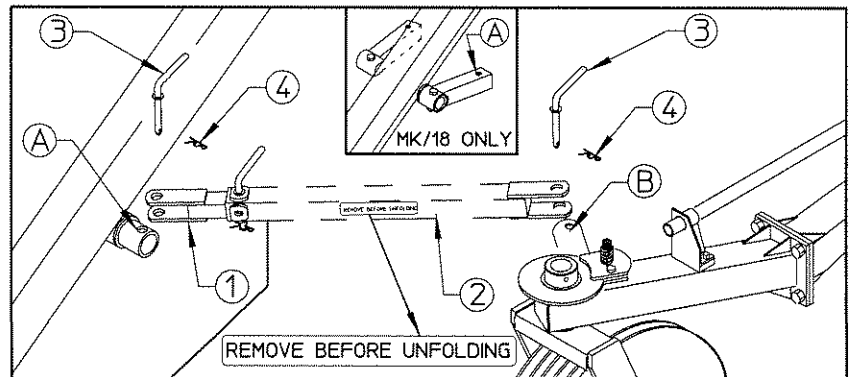

TRANSPORT LOCK ARMS CANNOT BE USED TO LOCK ONE RAKING WING, R.H. OR L.H. IN ORDER TO WORK ON ONE SIDE ONLY BECAUSE THIS IS NOT ALLOWED.



CAUTION !!

4 6

By operating the opening cylinders 1, the machine is opened to the fully open position.

NOTE: If work must be done on particularly uneven ground, do not operate in the fully open position. Open the machine so that it is at 3' narrower than the fully opened position.

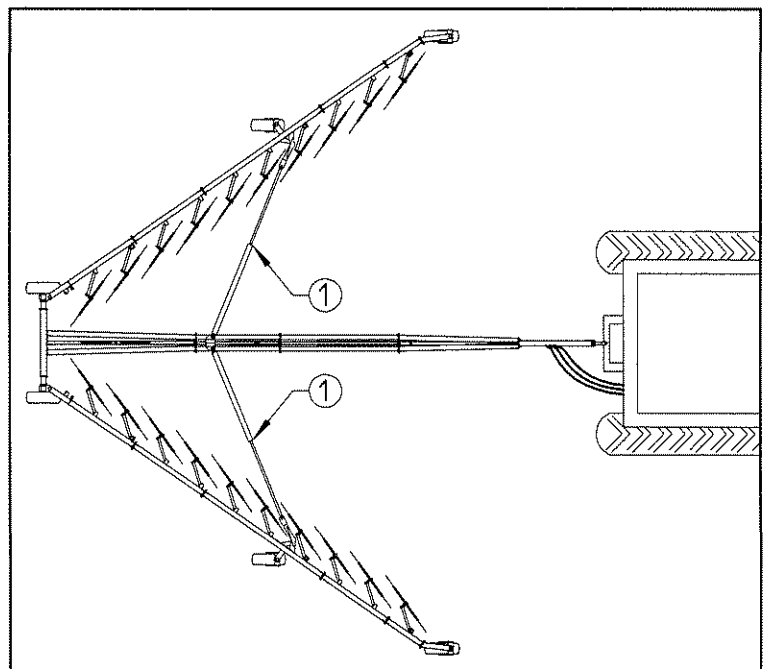

⚠ CAUTION !!

4 7

IMPORTANT !

Before starting to work it is necessary to move pin 1 and clip 2 from position "A" to position "B".
Operate cylinders 3 to lower the rake wheels.

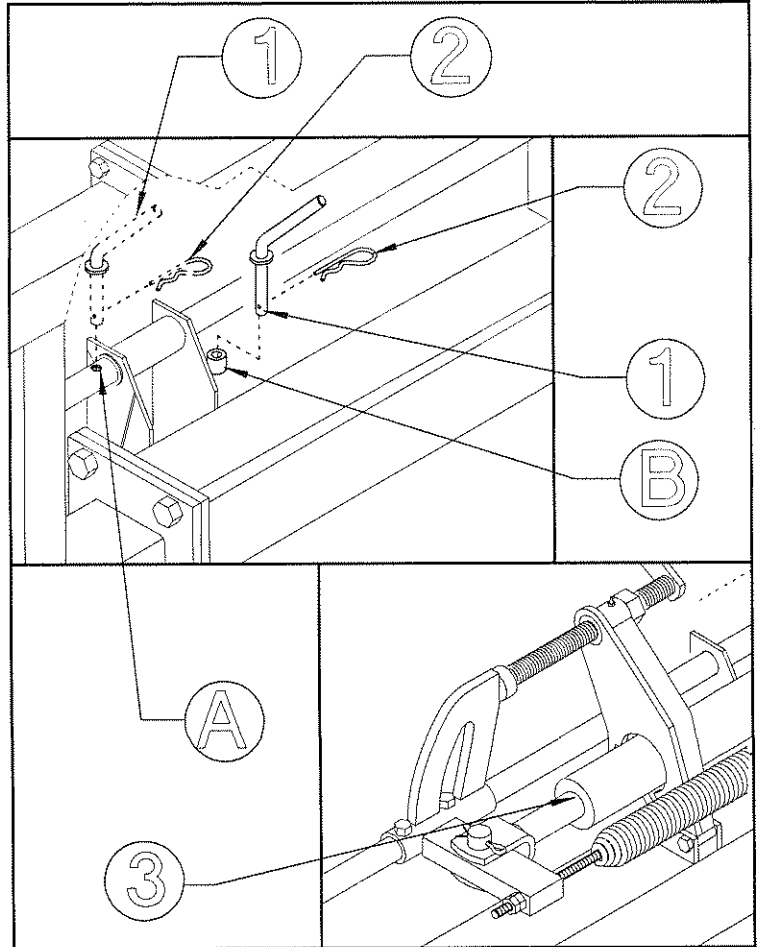

⚠ CAUTION !!

4 8

Adjust rake wheel pressure on the ground by turning crank 1.
Normally the rake tines should brush the ground.
When properly adjusted, tighten nut 2 to lock the screw of lever 1 in place.

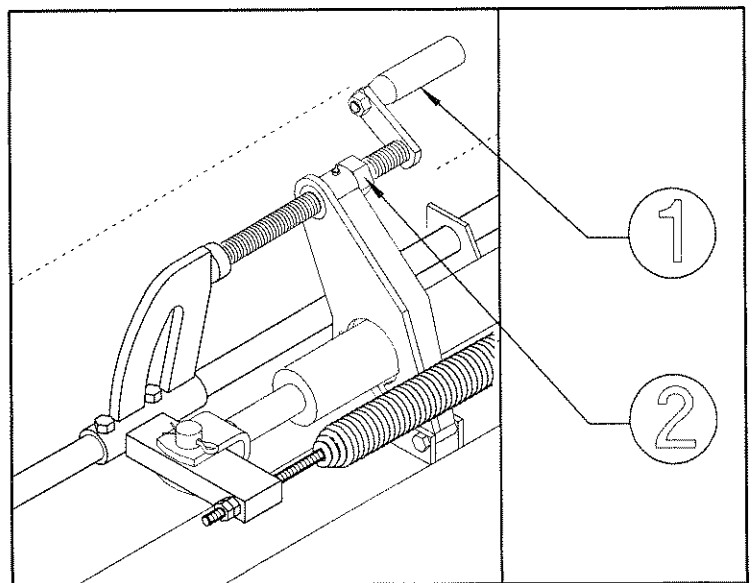

IMPORTANT !
 REAR OPENING
 STARTS AT 72"
 TO A MAXIMUM
 OF 88" AND
 THIS ALLOWS
 TO OBTAIN
 WINDROWS FROM
 APPROXIMATELY
 3' AND 6" TO
 A MAXIMUM OF
 5' AND 6".

NOTE : These
 measures are
 approximate
 and vary due
 to the type of
 forage, conditions
 of the forage
 (whether it is
 more or less dry)
 and the type of
 ground.

⚠ CAUTION !!

4 9
 The windrow width's
 adjustment is done
 by using ratchet link 1.

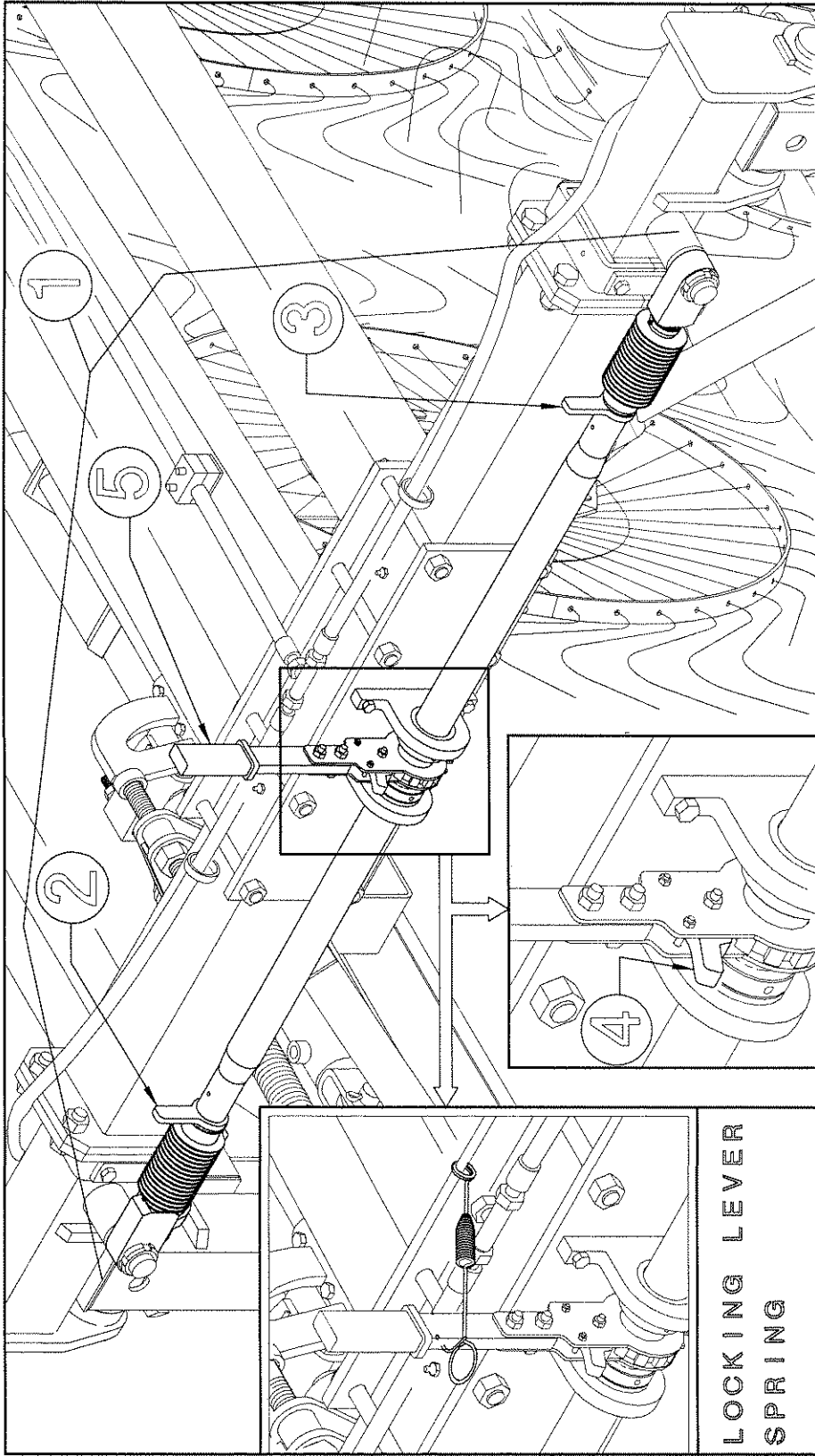

To do that, release, first of
 all, the locks 2 & 3, then,
 turn as needed the hook 4 to
 obtain the widening or tightening
 of windrow. A this point, by
 acting on lever 5 you can adjust

as needed and then re-lock the
 ratchet link 1 into the new
 position with locks 2 & 3.
IMPORTANTE: This operation must
 be done on a flat ground.

HYDRAULIC REAR OPENING
KIT ASSEMBLING

⚠ CAUTION !!

1

Attach the eye hose 1 to hole "A" of the cylinder valve and fasten it with washers 2 and fitting 3. Attach washer 2 and nipple 5 to the rear of flow

In this step, you will use:

Item 1: 2 hoses (3/8"), length 720 (3/8" x 2'4 21/64")

Item 2: 6 copper washers 3/8"

Item 3: 2 screws 3/8"

Item 5: 2 nipples 3/8" - 3/8"

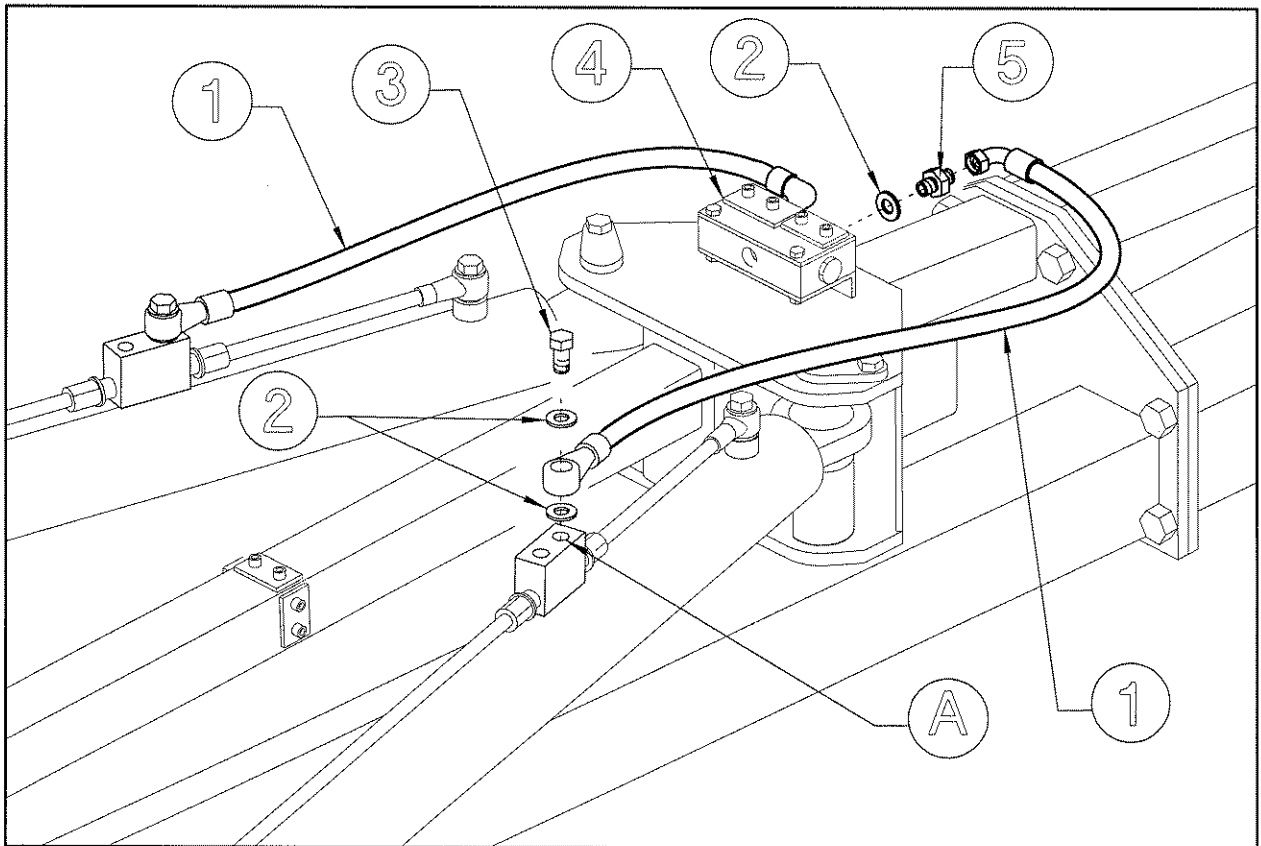

2

Fit the flow divider 1 and the hose collar plate 2 to support "A" on the drawbar. Fasten in place with screws 3 and nuts 4.

In this step, you will use:

Item 3: 2 screws M6x60 (15/64" x 2 3/8")

Item 6: 2 nuts M6 (15/64")

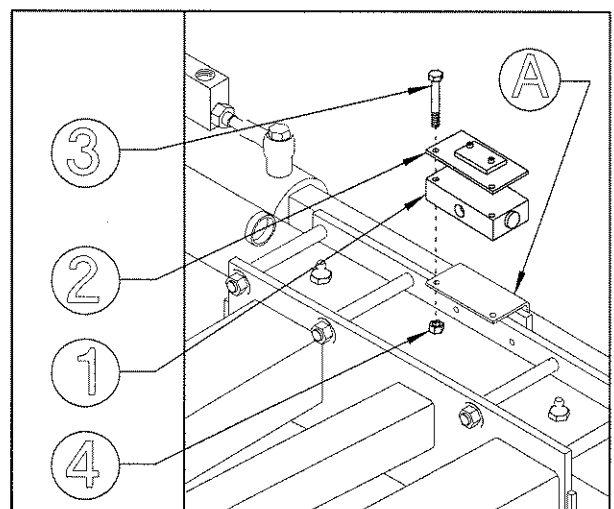

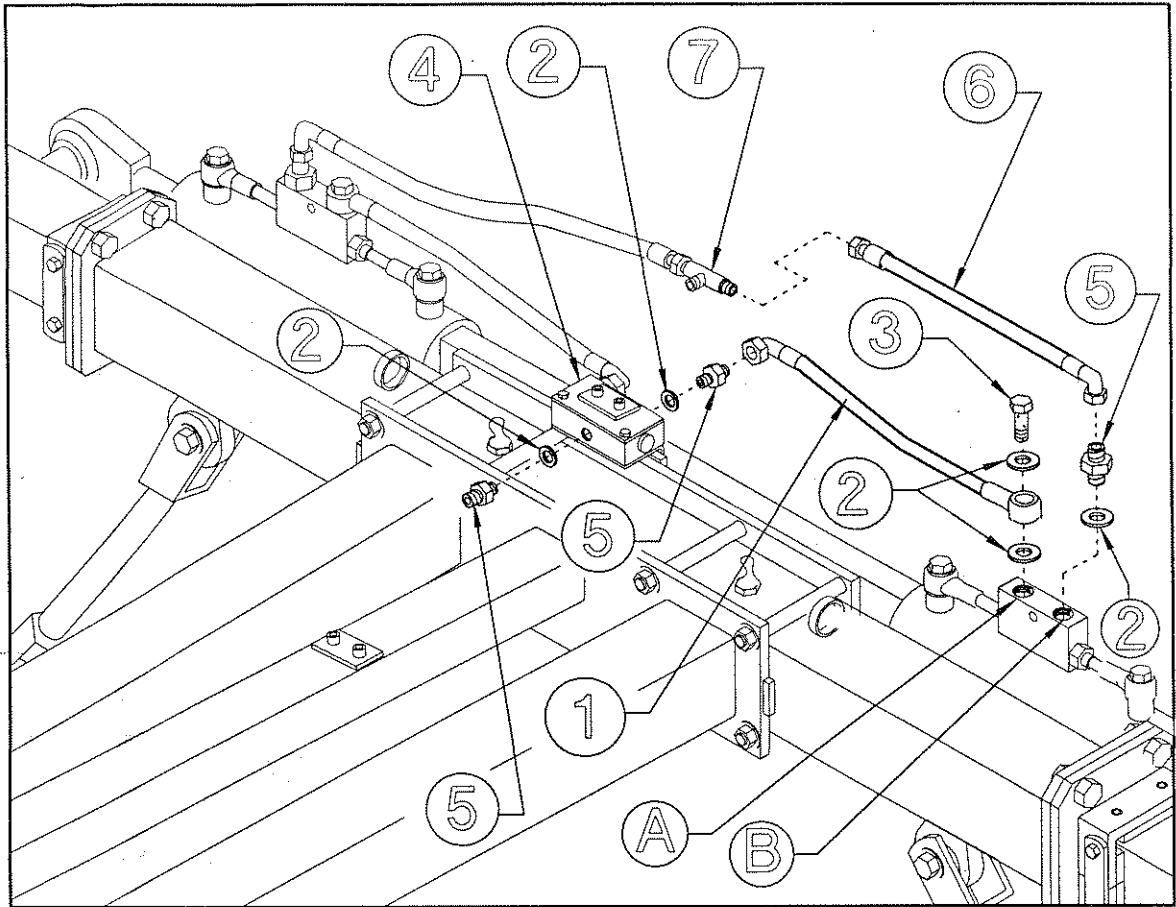

⚠ CAUTION !!

3

Attach the eye hose 1 to hole "A" of the cylinder valve and fasten it with washers 2 and fitting 3. Attach washer 2 and nipple 5 to the rear of flow divider 4. Connect the curved end of hose 1 to nipple 5. Attach washer 2 and nipple 5 to hole "B" in cylinder valve. Connect the curved end of hose 6 to nipple 5. Join hoses 6 to T connector 7 at the center of the machine.

Attach washer 2 and nipple 5 to the front of flow divider 4.

In this step, you will use:

Item 1: 2 hoses (3/8"), length 440 (3/8" x 17 3/8")

Item 2: 9 copper washers 3/8"

Item 3: 2 screws 3/8"

Item 5: 5 nipples 3/8" - 3/8"

Item 6: 2 hoses (3/8") length 480 (3/8" x 18 7/8")

Item 7: 1 male -female "T" connector 3/8"

⚠ CAUTION !!

4

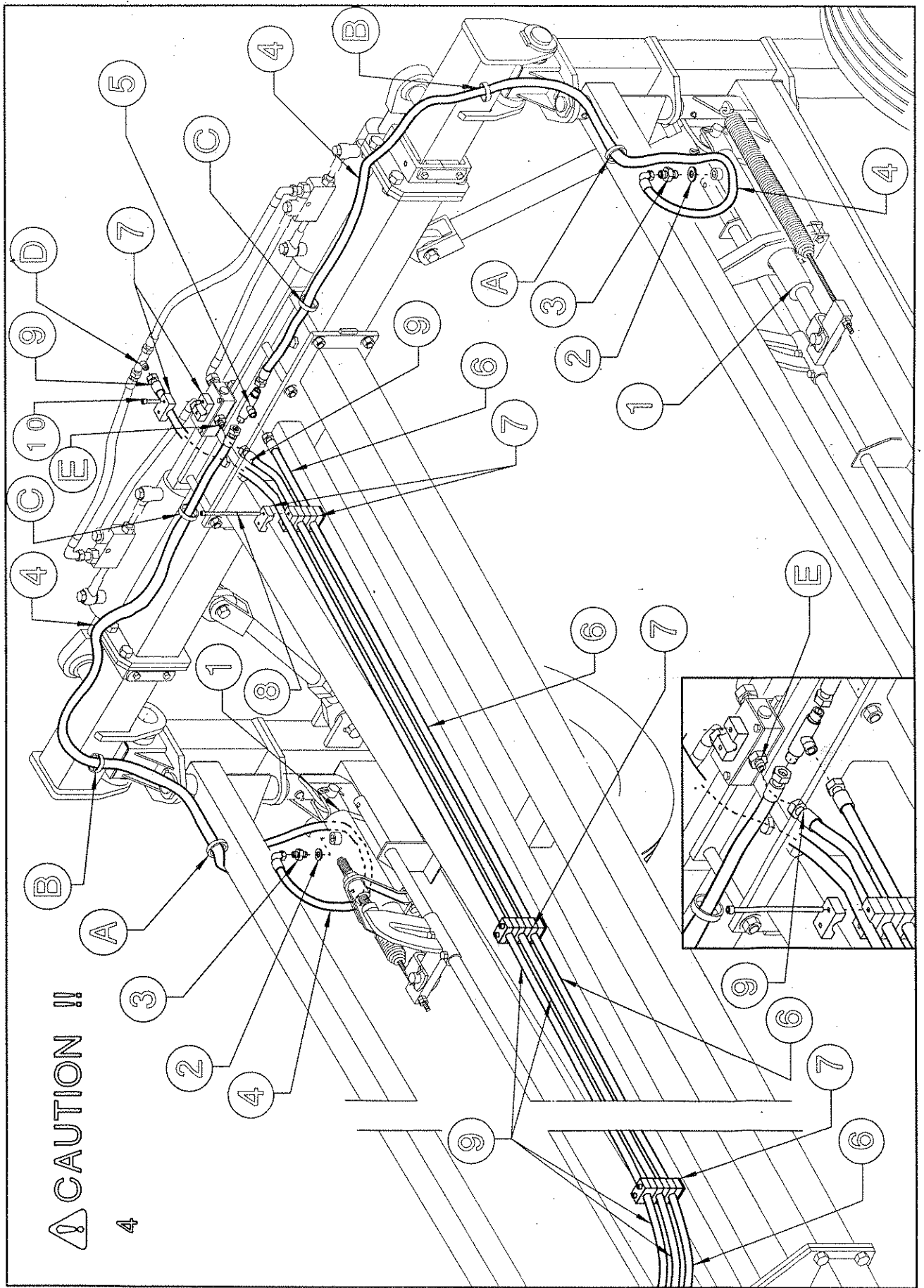

⚠ CAUTION !!

4

Attach washers 2 and nipples 3 to cylinders 1. Connect the curved end of hoses 4 to nipples 3. Pass hoses 4 through rings "A"- "B"- "C" and connect to "T" connector 5 at the center of the machine .
Connect the hoses 6 to "T" connector 5.

The hoses 9 are two. Connect one of these to nipple "E"; connect the other hose 9 to "T" connector "D".

Secure hoses 9-6 in the correct places with hose collars 7 and screws 8 and 10.

NOTE: Hoses 6-9 will also be in the next few steps.

In this step, you will use:

Item 2: 2 copper washers 3/8"

Item 3: 2 nipples 3/8" - 3/8"

Item 4: 2 hoses (3/8") length

2060 (3/8" x 6' 9")

Item 5: 1 male T connector 3/8"

Item 6: 1 hoses (3/8") length

7720 (3/8" x 25' 4")

Item 7: 20 hose collars dia 18 (45/64")

Item 8: 6 hexagon socket head cap screws M6 x 90 (15/64" x 3 35/64")

Item 9: 2 hoses (3/8") length 12900 (3/8" x 42' 3 1/2")

Item 10: 2 hexagon socket head cap screws M6 x 25 (15/64" x 1")

⚠ CAUTION !!

5

Continue to secure hoses 6-9 using collars 1 and screws 2-3.

NOTE: At point "A" lock hose 6 only. To avoid problems due to interfering with cylinder "B", hoses 9 will be re-locked afterwards.

Hoses 6-9 will also be in the next few steps.

In this step, you will use:

Item 1: 8 hose collars dia 18 (45/64")

Item 2: 2 hexagon socket head cap screws M6x25 (15/64"x 1")

Item 3: 2 hexagon socket head cap screws M6x90 (15/64"x 3" 35/64")

Item 6-9: see preceding step.

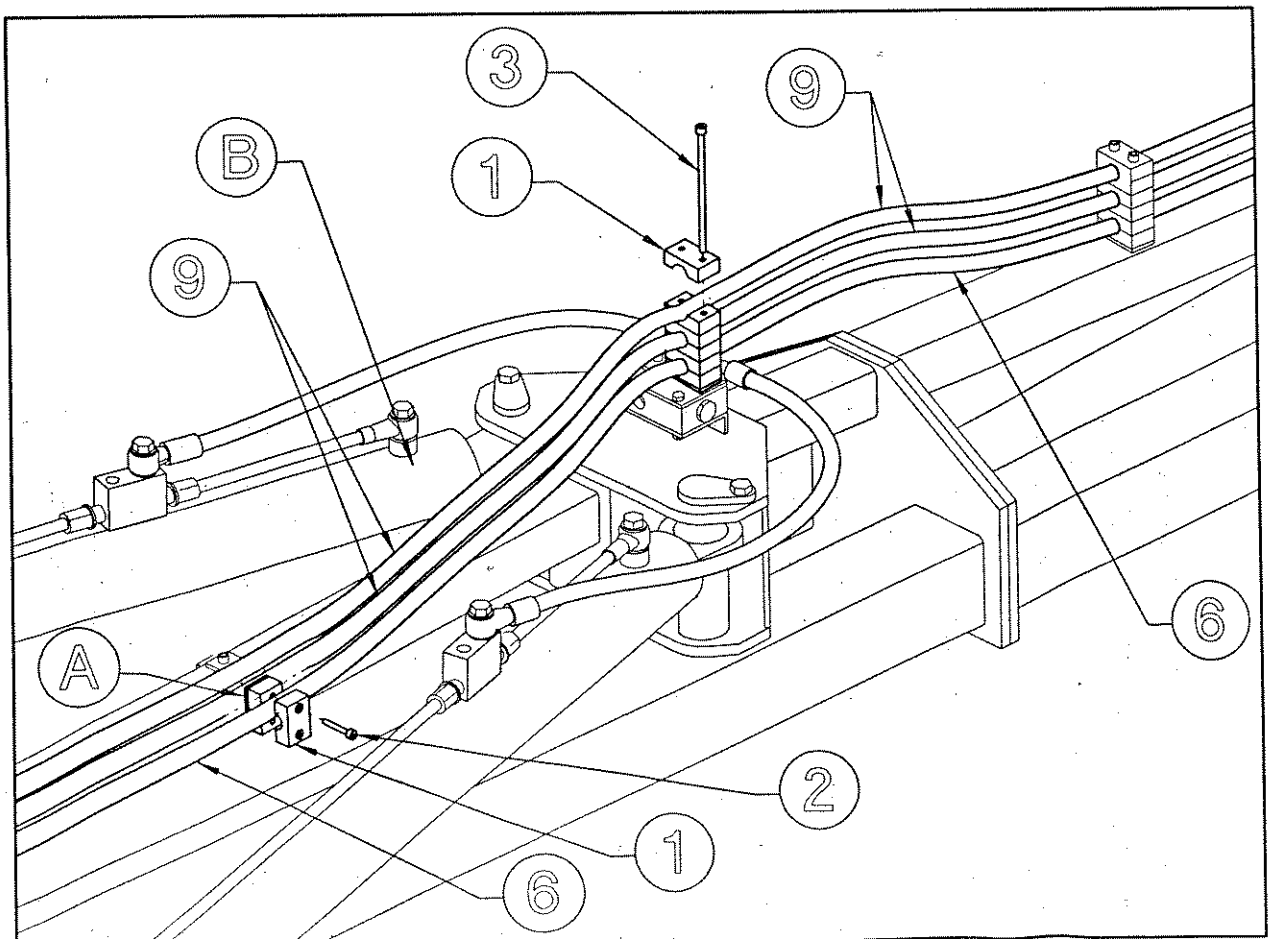

⚠ CAUTION !!

6

Attach washer 1 and nipple 2 to hole "A" in cylinder valve. Connect the curved end of hose 3 to nipple 2. Join hoses 3 to T connector 4 at the center of the machine. We recommend to pass hoses 3 and fitting 4 through hose 6 and hoses 9. Hoses 6-9 will also be in the next few steps.

In this step, you will use:
Item 1: 2 copper washers 3/8"
Item 2: 2 nipples 3/8" - 3/8"
Item 3: 2 hoses (3/8") length 750 (3/8" x 2' 5" 1/2)
Item 4: 1 male-female T connector 3/8".
Item 6-9: see preceding step.

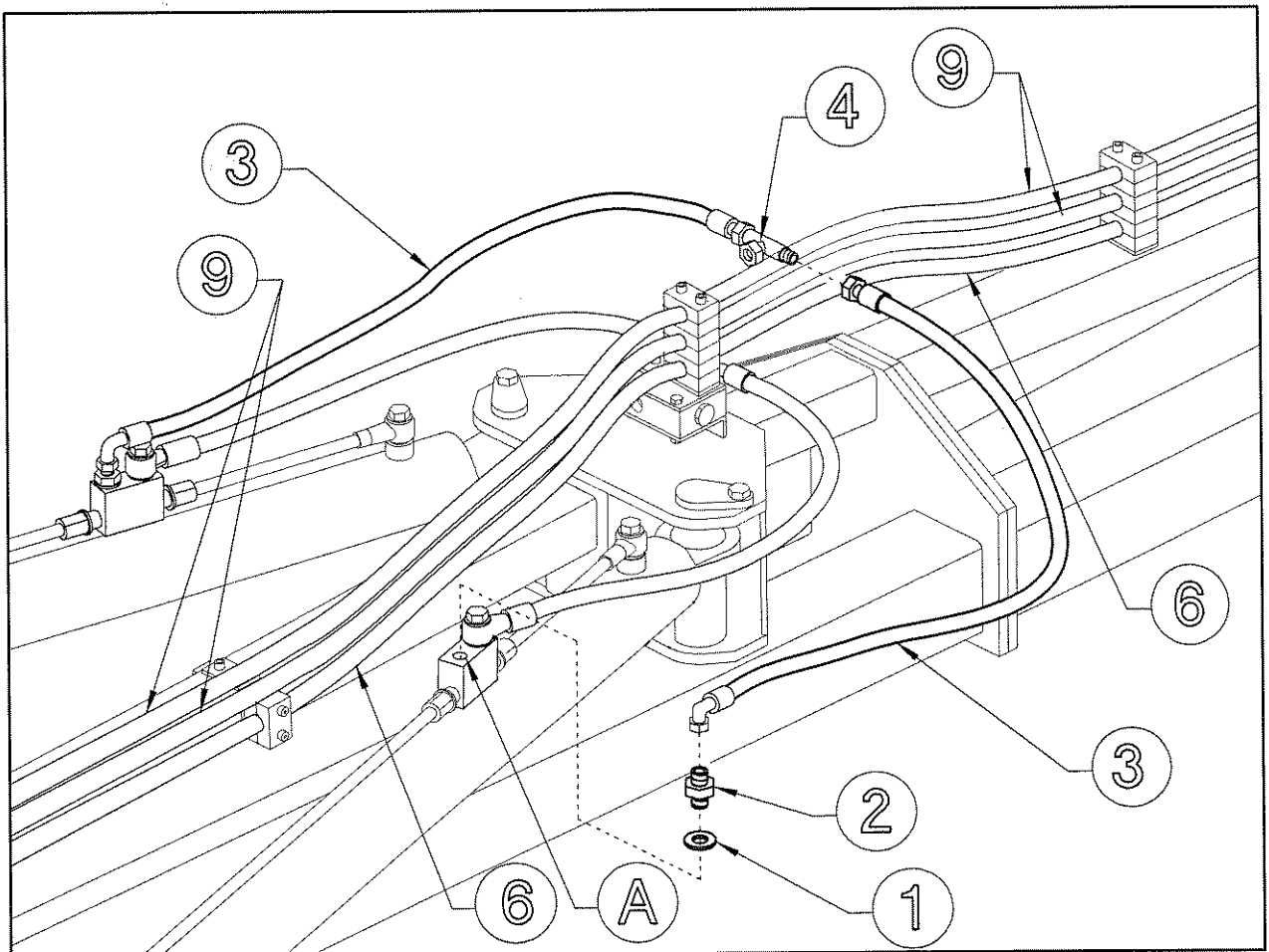

⚠ CAUTION !!

7

Screw nipple 1 into hole "A" of the T connector. Screw hose 2 onto nipple 1. Secure hose 2 in place with collars 4 and screw 5. Screw nipple 1 and washer 7 into hole "B" of the flow divider.

Screw hose 3 onto nipple 1 and secure in place with collars 4 and screw 5.

NOTE: Hoses 2-3 will also be in the next few step.

In this step, you will use:

Item 1: 2 nipples $3/8"$ - $1/2"$

Item 2: 1 hose ($1/2"$) length 9630 ($1/2"$ x 31' 7")

Item 3: 1 hose ($1/2"$) length 9480 ($1/2"$ x 31' 1")

Item 4: 6 hose collars dia.22 ($7/8"$)

Item 5: 6 hexagon socket head cap screws M6x30 ($15/64"$ x $1" 3/16"$)

Item 7: 1 copper washer $3/8"$

Item 6-9: see preceding step.

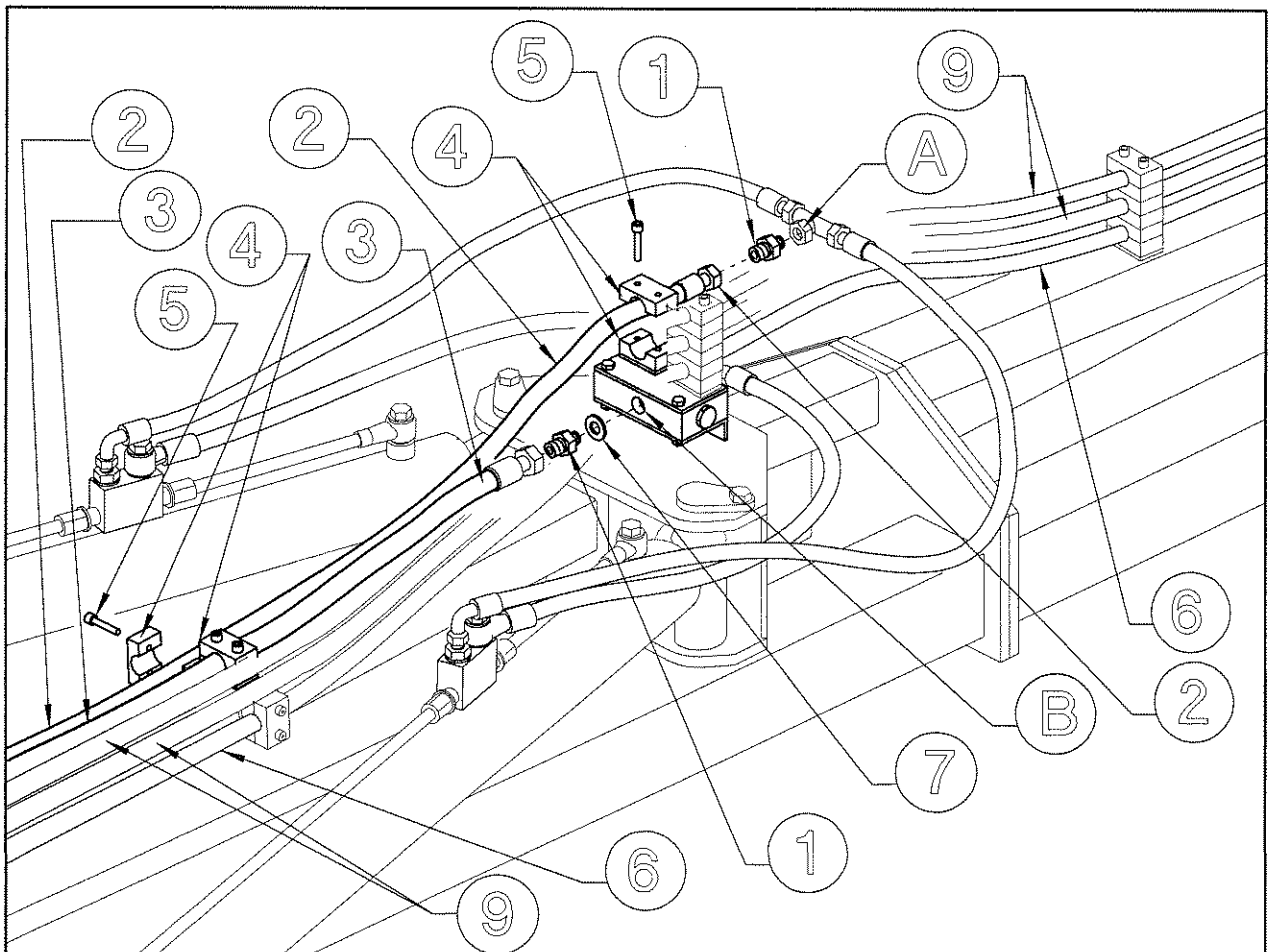

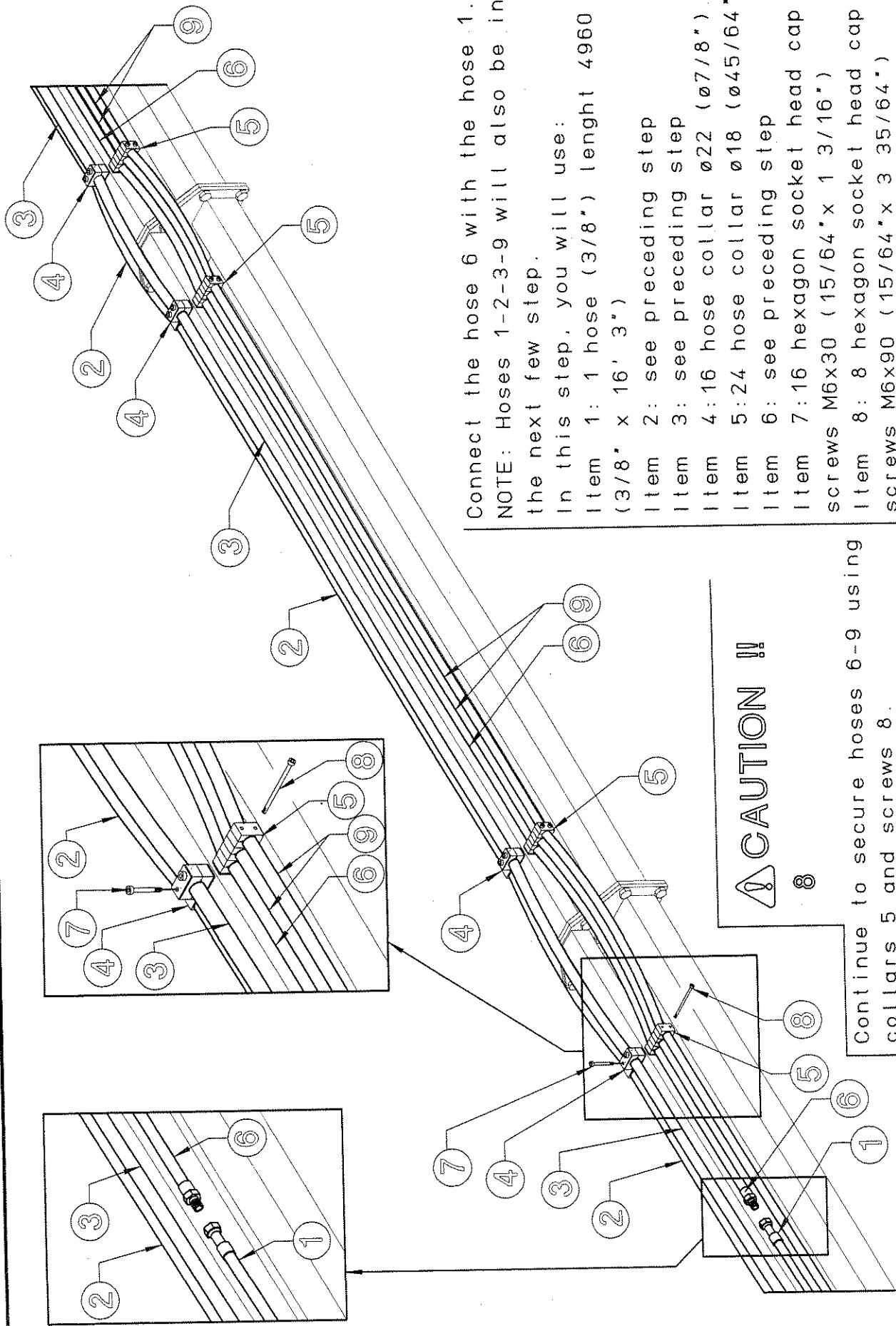

Connect the hose 6 with the hose 1.
 NOTE: Hoses 1-2-3-9 will also be in the next few steps.

In this step, you will use:

- Item 1: 1 hose (3/8") length 4960 (3/8" x 16' 3")
- Item 2: see preceding step
- Item 3: see preceding step
- Item 4: 16 hose collar $\varnothing 22$ ($\varnothing 7/8"$)
- Item 5: 24 hose collar $\varnothing 18$ ($\varnothing 45/64"$)
- Item 6: see preceding step
- Item 7: 16 hexagon socket head cap screws M6x30 (15/64" x 1 3/16")
- Item 8: 8 hexagon socket head cap screws M6x90 (15/64" x 3 35/64")
- Item 9: see preceding step

CAUTION !!

Continue to secure hoses 6-9 using collars 5 and screws 8.
 Continue to secure hoses 2-3 using collars 4 and screws 7.

⚠ CAUTION !!

9

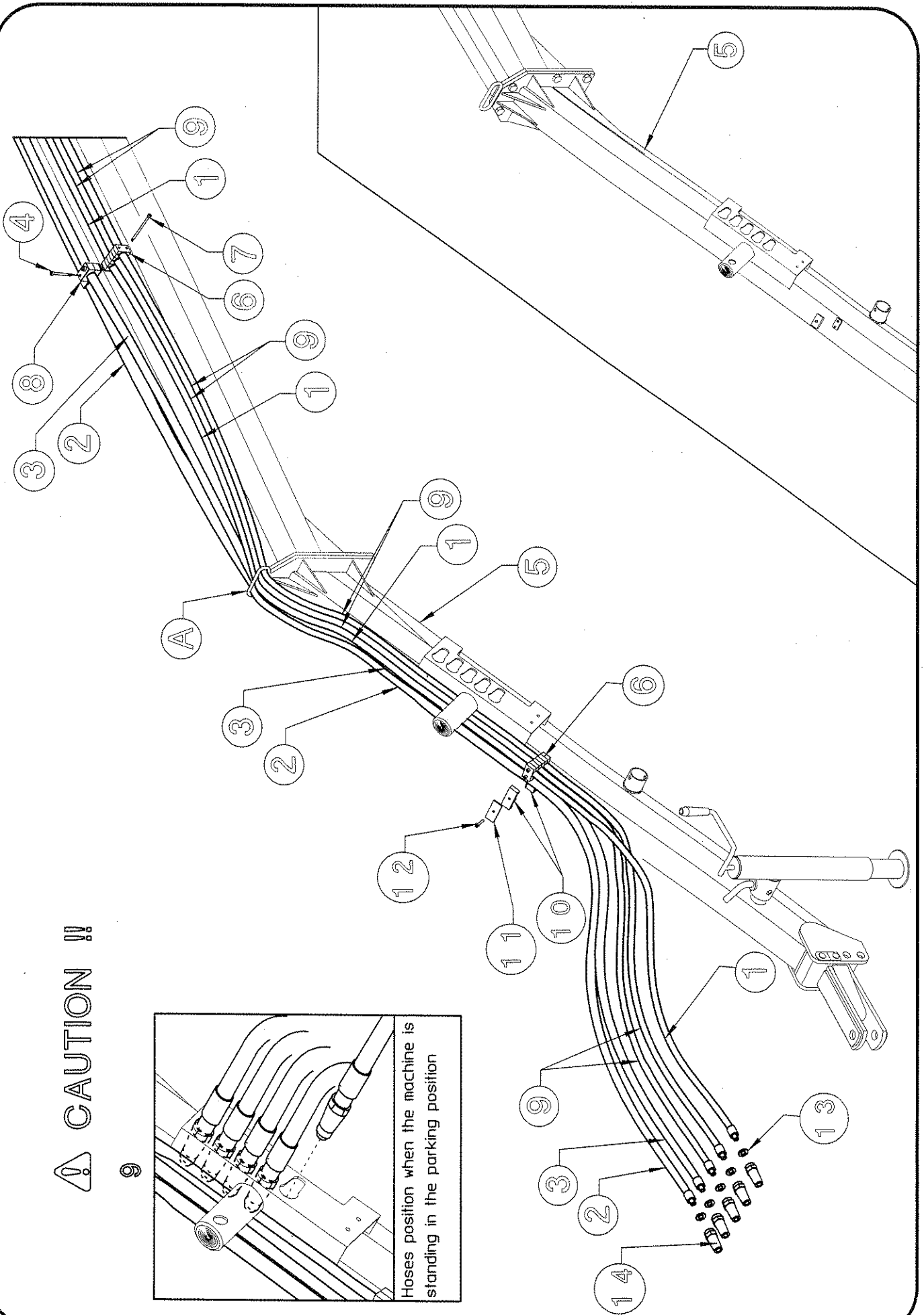
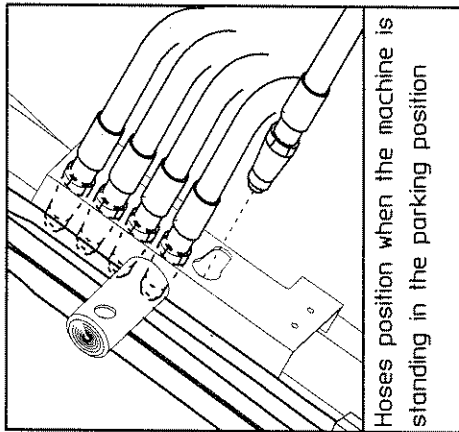

 CAUTION !!

9

Pass hoses 1-2-3-9 through loop "A" on drawbar 5.
Secure hoses 1-9 in the correct places with hose collars 6 and screws 7. Secure hoses 2-3 in the correct places with hose collars 8, screws 4, double hose collars 10, plate 11 and screw 12.
Attach washers 13 and quick-release couplings 14 to the end of hoses 1-2-3-9.

In this step, you will use:

- Item 1: see preceding step
- Item 2: see preceding step
- Item 3: see preceding step
- Item 4: 4 hexagon socket head cap screws M6 x 30 (15/64" x 1" 3/16).
- Item 6: 12 hose collars $\varnothing 18$ ($\varnothing 15/64$ ")
- Item 7: 4 hexagon socket head cap screws M6 x 90 (15/64" x 3 35/64")
- Item 8: 4 hose collars $\varnothing 22$ ($\varnothing 7/8$ ")
- Item 9: see preceding step
- Item 10: 2 double hose collars $\varnothing 22$ ($\varnothing 7/8$ ")
- Item 12: 1 screws M8 x 45 (5/16" x 1 3/4")
- Item 13: 5 copper washers 1/2"
- Item 14: 5 quick-release coupling 1/2"

MAINTENANCE POINTS

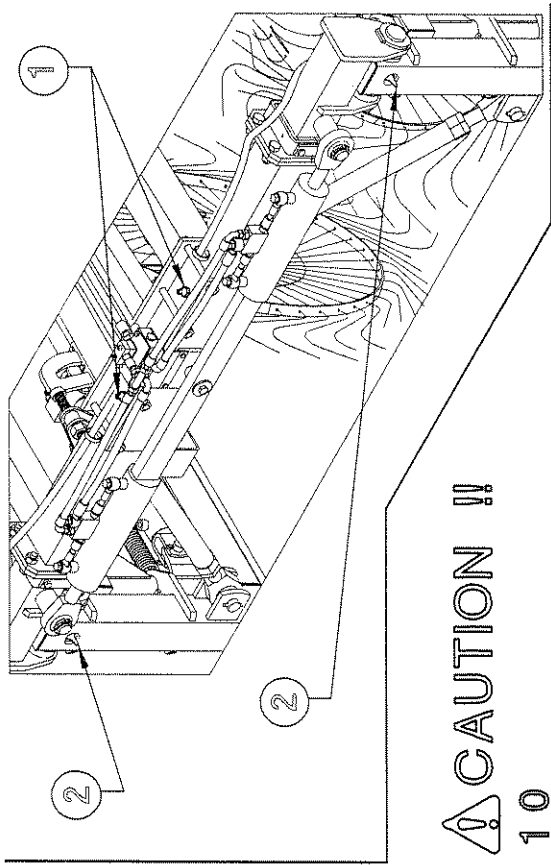
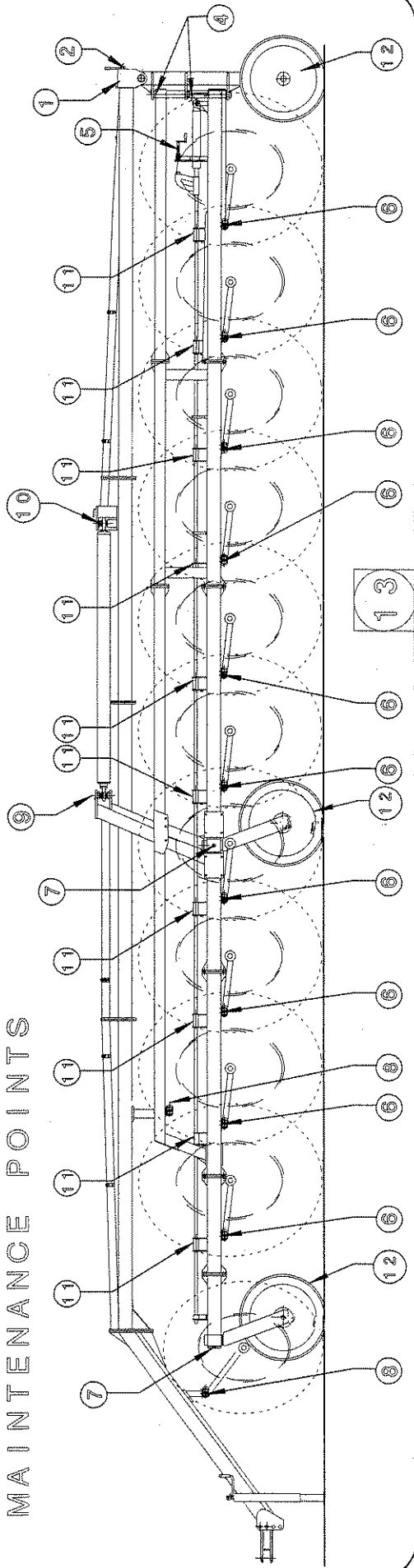

CAUTION !!

10

At this point, the machine is completely assembled. Before testing for operation, it is necessary to lubricate and check the movement of all parts. This diagram gives the maintenance program, to be carried out in its entirety the first time, and subsequently according to the schedule as shown.

ITEM Q.ty	DESCRIPTION	OPERATION	EVERY x HOURS
1	Fixed cross member	Lubricate	A
2	Rear wheel support	"	25
4	Rake wheel section joints	"	8
5	Crank screws	"	A
6	Rake wheel bracket joints	"	25
7	Wheel support joints	"	8
8	Small rake wheel joints (optional)	"	25
9	Opening cylinder head joints	"	16
10	Opening cylinder foot joints	"	16
11	Pipe supports	"	25
12	Tires	Check pressure	A
13	General checking of bolts, security pins and split pins to be carried out initially after the first 8 hours of use. Subsequently every 50 hours and whenever the machine is laid up for extended periods.		
A = EVERY TIME THE PART IS USED			

GENERAL INSTRUCTIONS FOR USE

⚠ DANGER !!!

1 1

To connect the machine to the tractor, first it is necessary to raise or lower parking stand 1 so that drawbar 2 is parallel to the ground. Back the tractor up to the machine and look to see if hitch 3 is aligned with tractor hitch 4. If hitch 3 is much higher or lower than tractor hitch 4, it is necessary to change the position of hitch 3 by choosing the

⚠ CAUTION !!

1 2

During transport and working the parking stand 1 must be shifted from position "A" to position "B".

This is done by removing clip 2 and pin 3 and moving stand 1 out of the parking position.

Fasten parking stand 1 into the transport position using pin 3 and clip 2.

holes in plate 5 which give the best alignment.

At this point connect hitch 3 to tractor hitch 4 using a suitable pin.

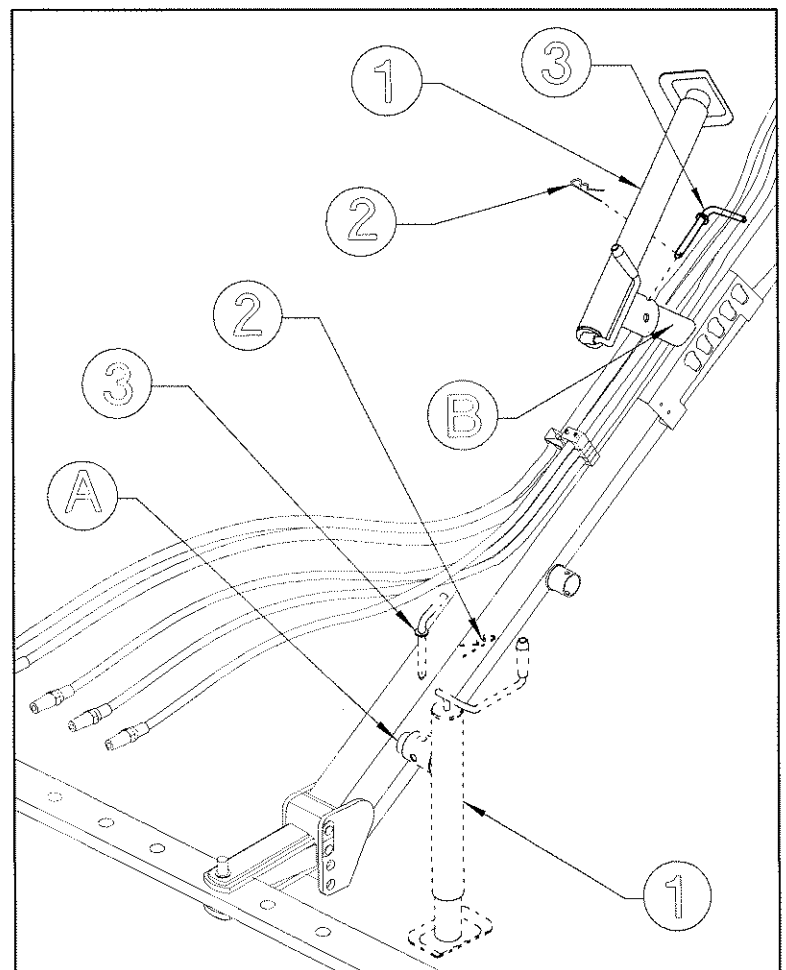
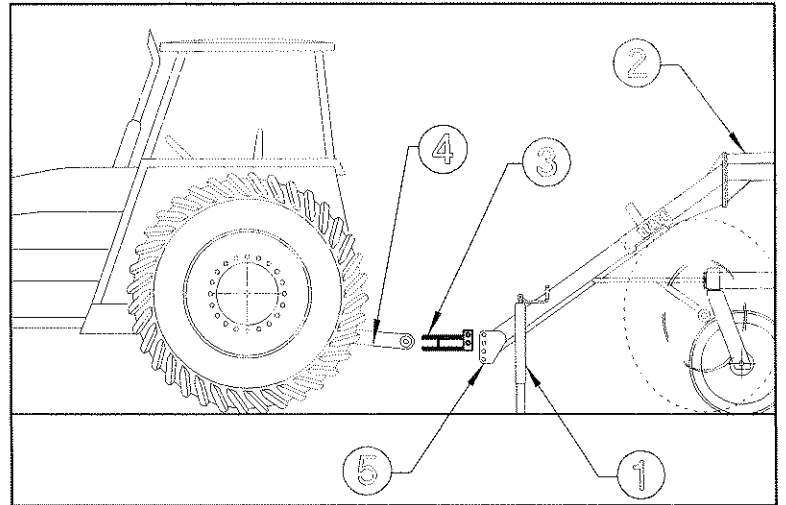

⚠ DANGER !!!

13

At this point quick-release couplings of hoses 1-2-3-4-5 should be attached to the relative tractor couplings 6-7-8-9-10. The movements of the machine are now controlled by operating levers A-B-C. Hoses 1-2, connected to tractor couplings 6-7, control the cylinders for opening the machine. Hoses 3-4, connected to tractor couplings 8-9 control the rear opening cylinders. Hose 5, connected to tractor coupling 10, controls the cylinders for lifting the rake

wheels. It is recommended that all movements be repeated a few times to eliminate air from the system. The machine is now ready for operation.

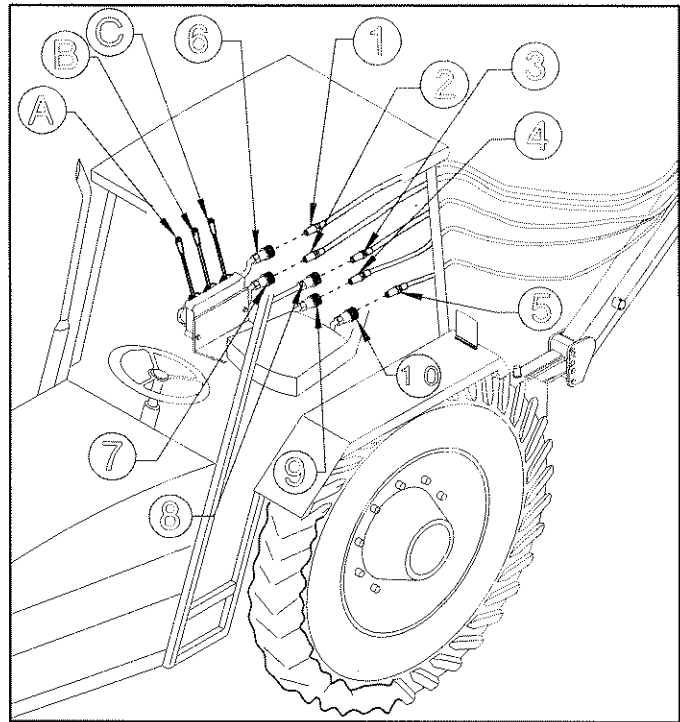

⚠ CAUTION !!

14

During transport it is necessary to move pin 1 and clip 2 from position "A" to position "B". This removes the load from the rake wheel lifting cylinders.

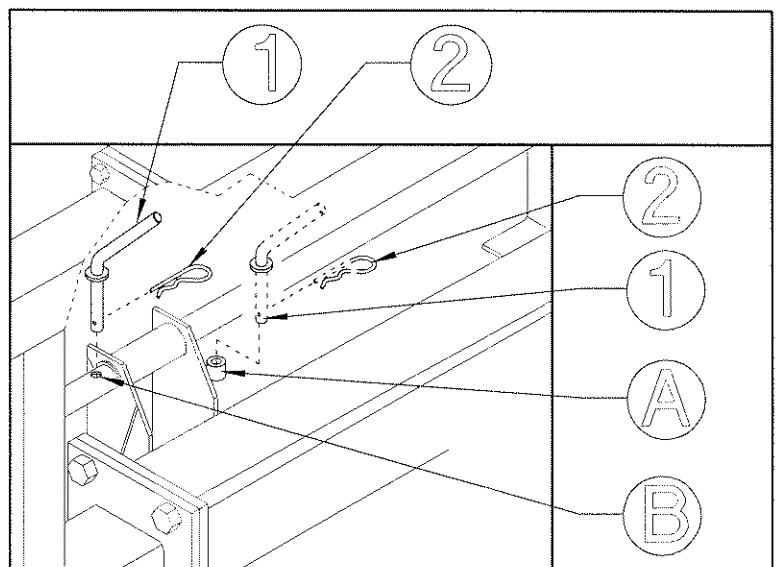

! DANGER !!!

15

At this point it is necessary to attach the transport arms. Insert arm 1 in arm 2 and lock in place with pin 3 and clip 4. The transport arm assembly is then attached by placing the fork of arm 1 on attachment A of the draw-

bar and the fork of arm 2 on the wheel support. Fasten with pins 3 and clips 4.

In this step, you will use:

Item 3: 6 pins $\varnothing 15 \times 87$
($\varnothing 19/32" \times 3 27/64"$)

Item 4: 6 clips $\varnothing 3$ ($\varnothing 1/8"$)

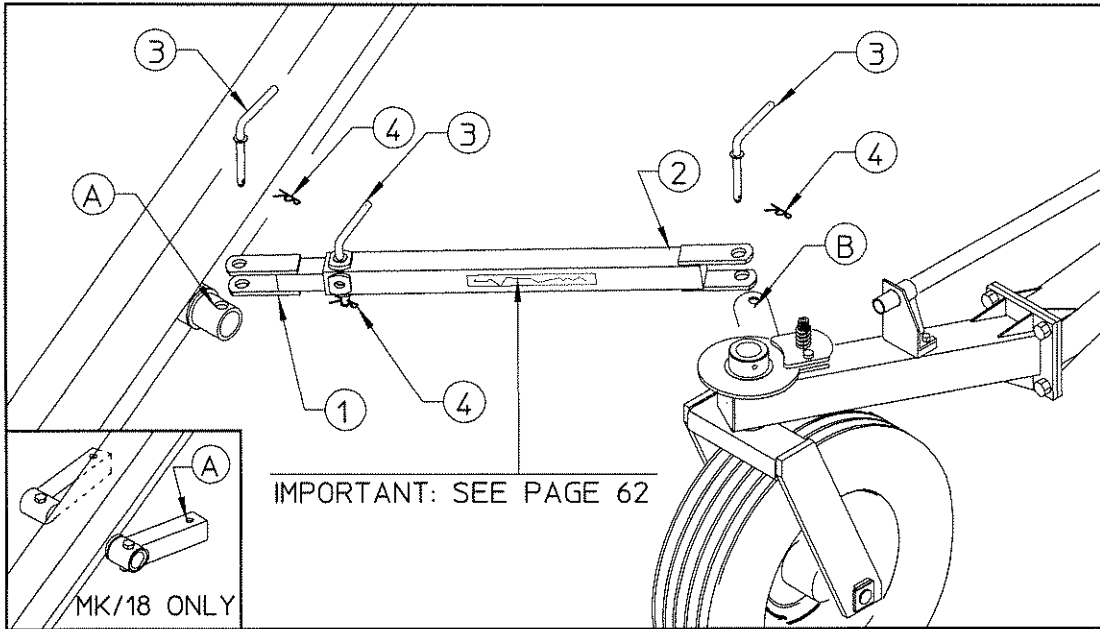

16

This is the assembly diagram for the MK20 and MK18. The row of holes on the arms is for when the rear axle is widened. Under no circumstances should the cylinders be operated while the transport arms are attached. The machine is now to be transported to the work site.

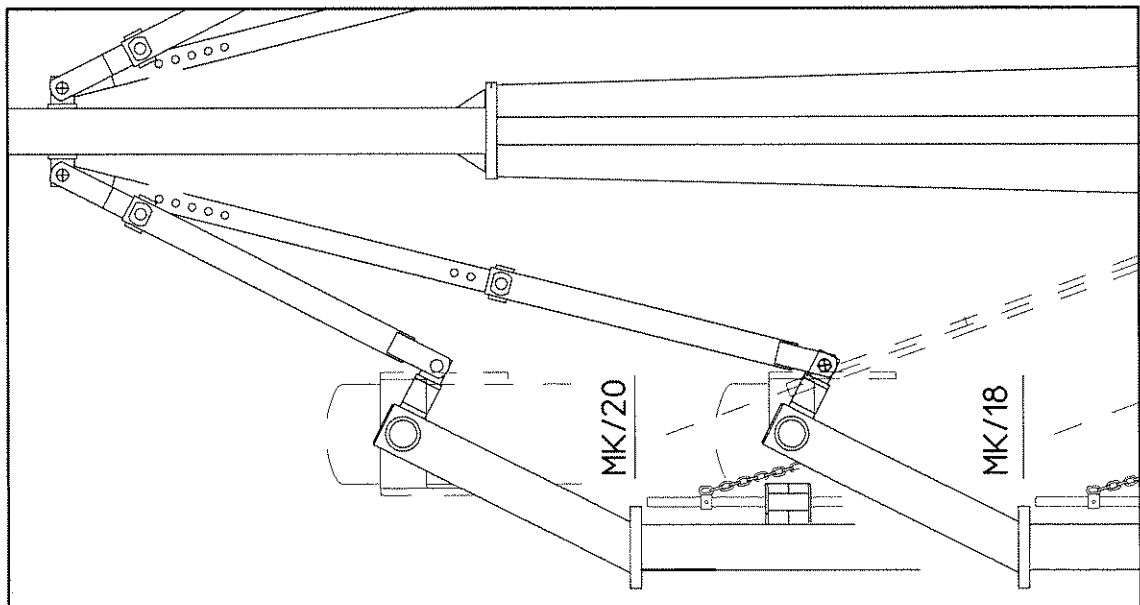

GENERAL INSTRUCTIONS FOR FIELD USE

⚠ CAUTION II

17

The first thing to be done in the field is to remove transport arm 1-2, replacing pins 3 in holes A-B and fastening them with clips 4. The transport arm 1-2 assemblies are to be placed over pins C-D on

the rake wheel sections as shown. Fasten the transport arm to pins C-D with clips 5.

In this step, you will use:
Item 5: 4 clips d.3 (1/8")

IMPORTANT I

BEFORE STARTING RAKING OPERATION MAKE SURE THAT THE TRANSPORT LOCK ARMS HAVE BEEN REMOVED FROM THE TRANSPORT POSITION AND SET IN WORKING POSITION.

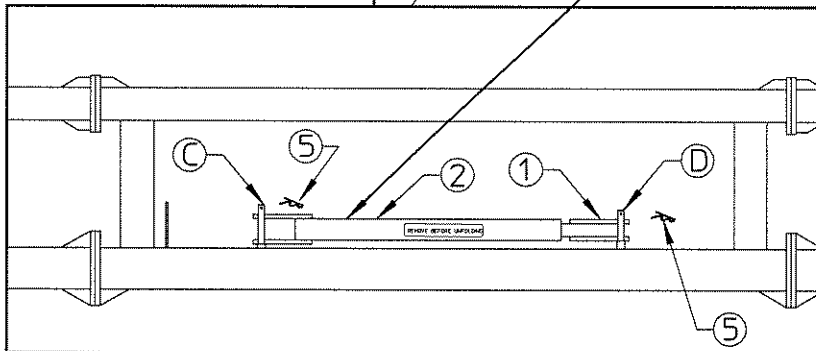
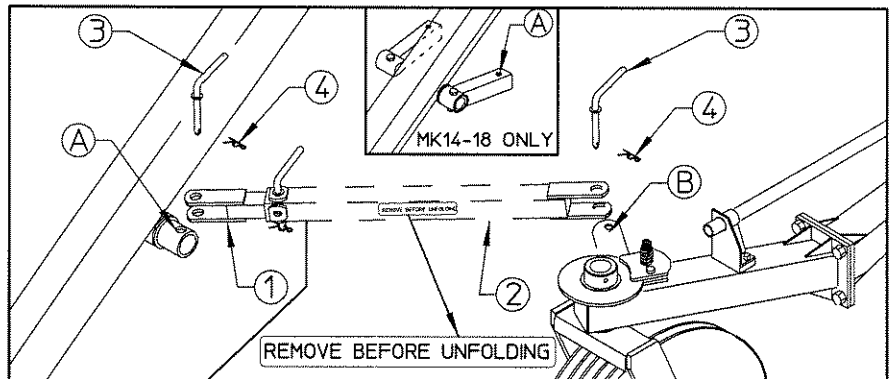

TRANSPORT LOCK ARMS CANNOT BE USED TO LOCK ONE RAKING WING, R.H. OR L.H. IN ORDER TO WORK ON ONE SIDE ONLY BECAUSE THIS IS NOT ALLOWED.

⚠ CAUTION II

18

By operating the opening cylinders 1, the machine is opened to the fully open position.

NOTE: If work must be done on particularly uneven ground, do not operate in the fully open position. Open the machine so that it is at 3' narrower than the fully opened position.

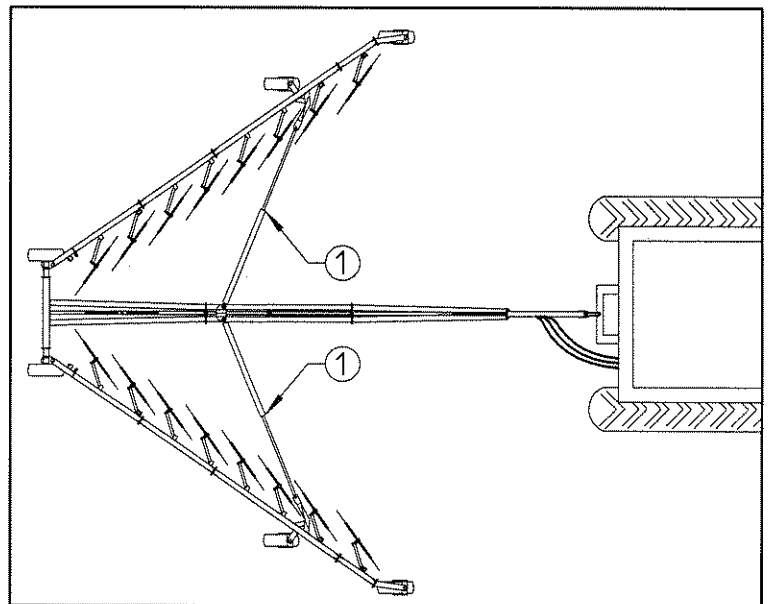

⚠ CAUTION !!

19

IMPORTANT !

Before starting to work it is necessary to move pin 1 and clip 2 from position "A" to position "B".
Operate cylinders 3 to lower the rake wheels.

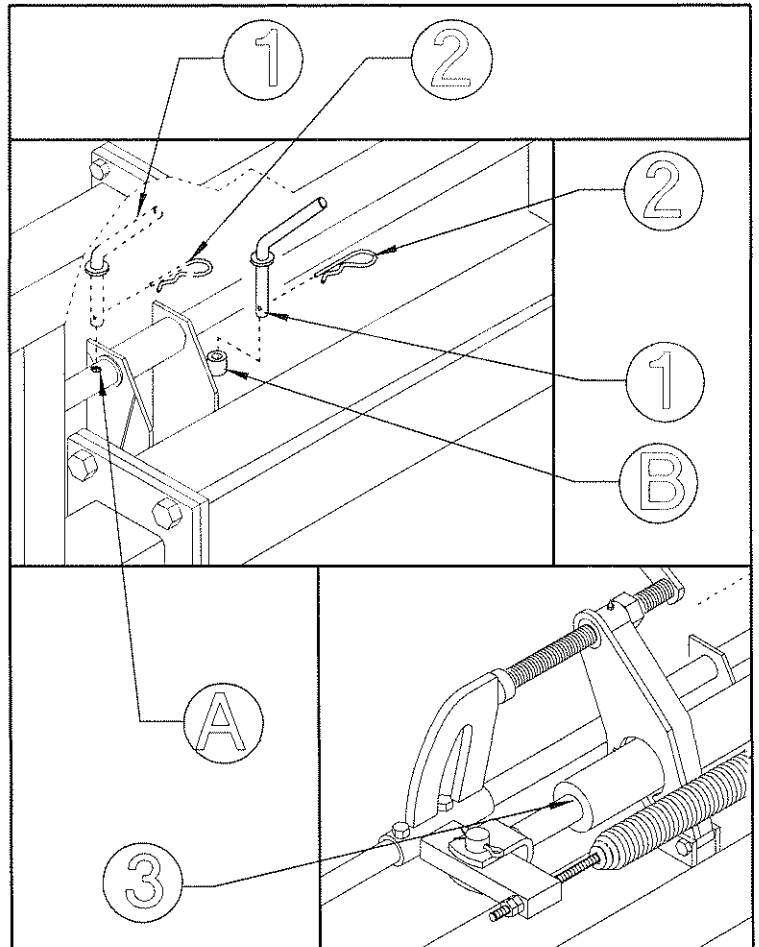

⚠ CAUTION !!

20

Adjust rake wheel pressure on the ground by turning crank 1.
Normally the rake tines should brush the ground.
When properly adjusted, tighten nut 2 to lock the screw of lever 1 in place.

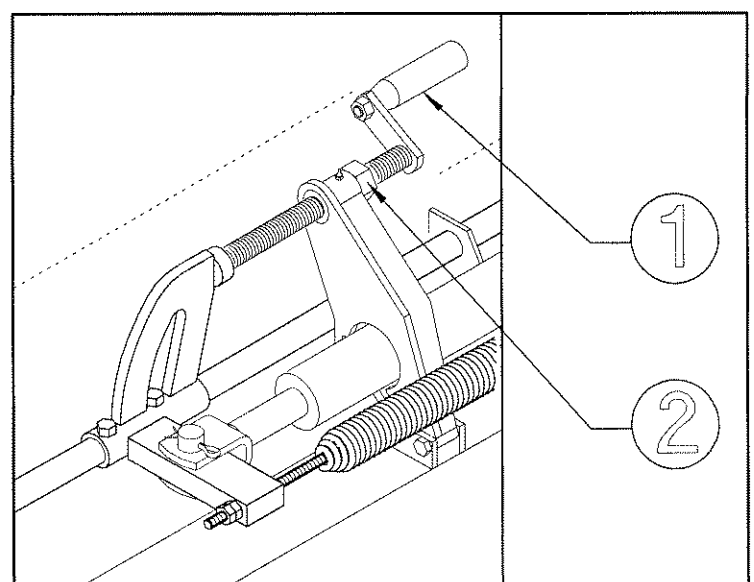

⚠ CAUTION !!

2 1

On this version the windrow width adjustment is made through cylinders 1 operated directly from tractor's seat. On this subject, see point 45 on page 44.

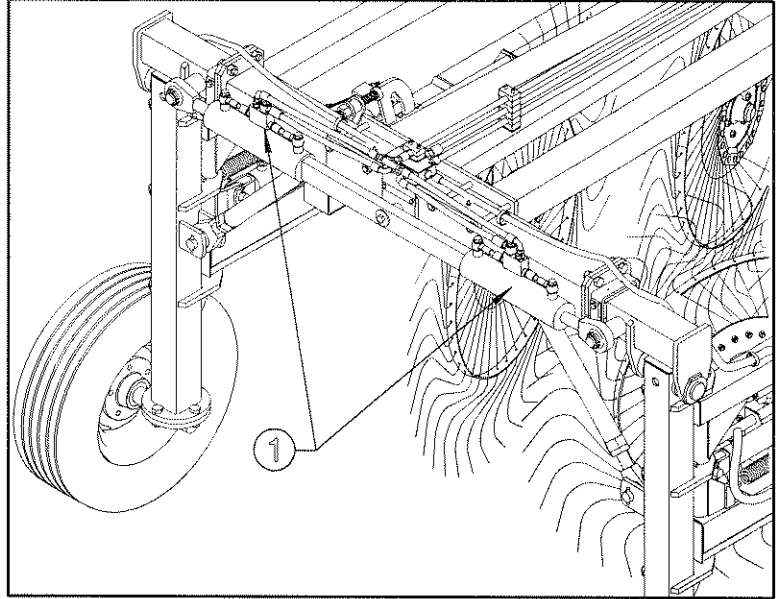

IMPORTANT !

REAR OPENING STARTS AT 72" TO A MAXIMUM OF 88" AND THIS ALLOWS TO OBTAIN WINDROWS FROM APPROXIMATELY 3' AND 6" TO A MAXIMUM OF 5' AND 6".

NOTE : These measures are approximate and vary due to the type of forage, conditions of forage (whether it is more or less dry) and the type of ground.

⚠ ATTENTION!!

2 2

VERY IMPORTANT:
as explicitly indicated on decals 1 you have to operate cylinders 2 only when machine is running.

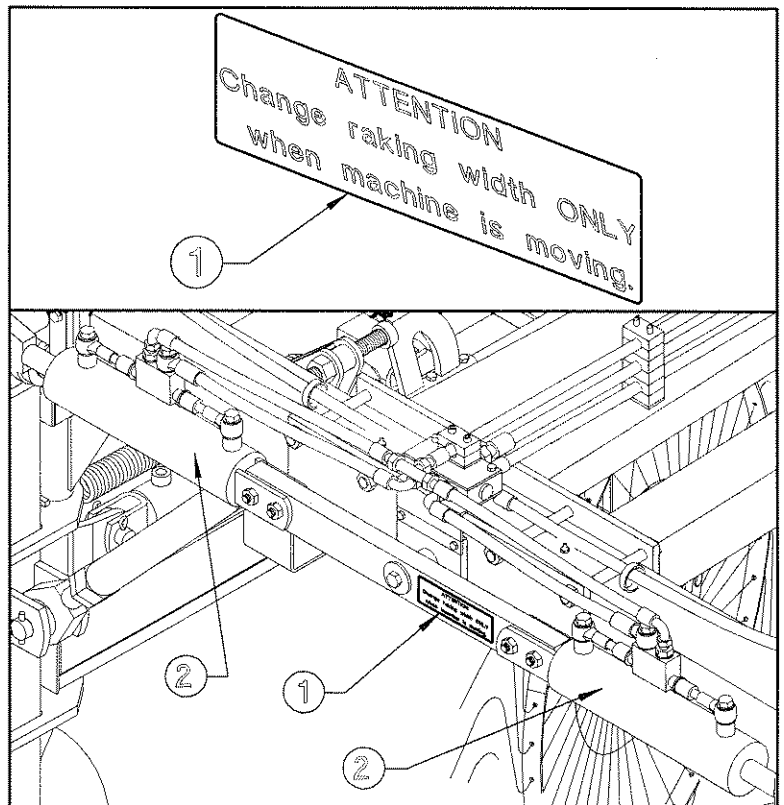

CENTRAL WHEELS KIT (OPTIONAL) INSTRUCTION FOR INSTALLATION

1

This is the diagram for positioning the various components of the central rake wheel kit.

2950 - 116 1/8"

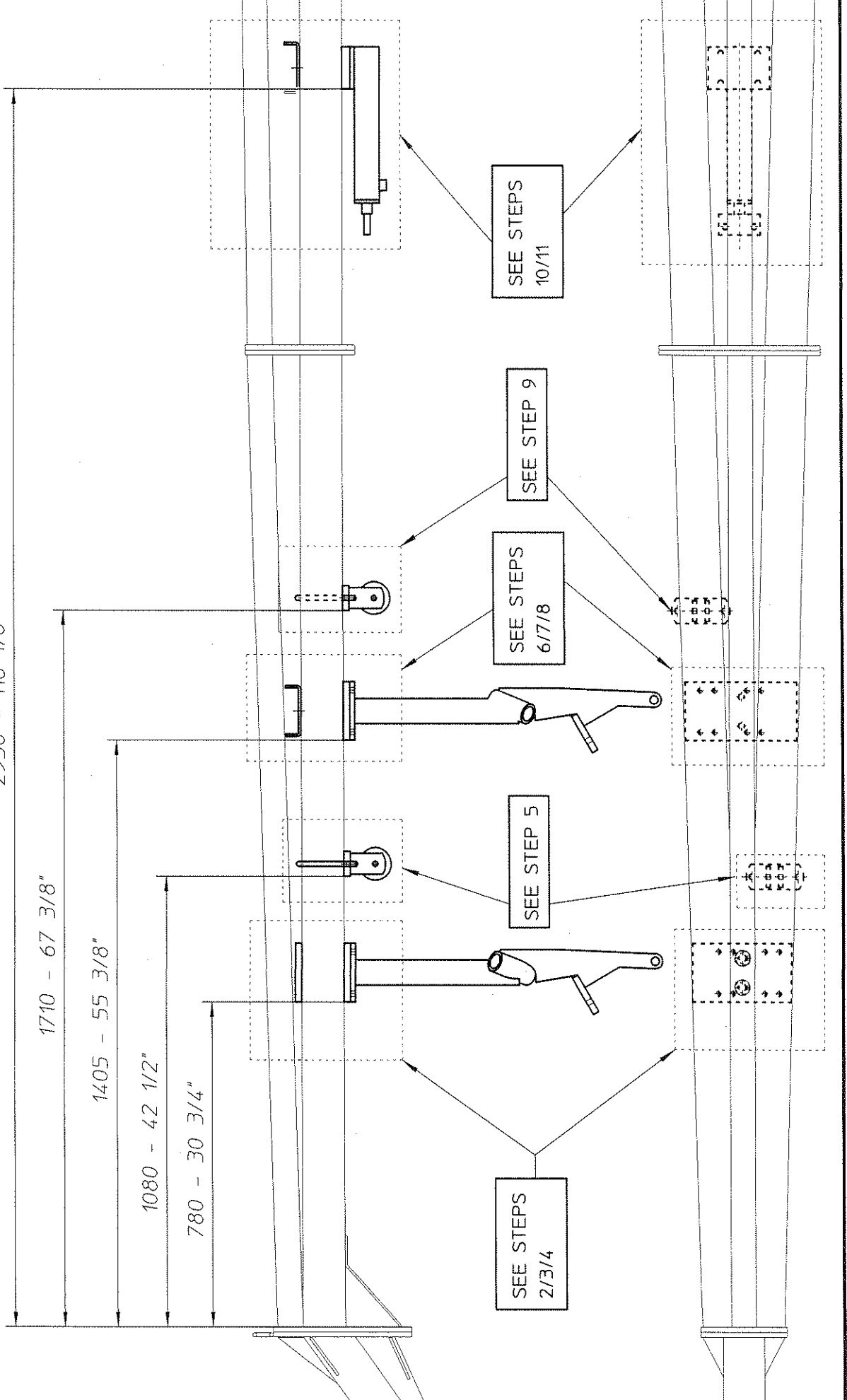

2

Plate 1 has the A-A1 and B-B1 pairs of holes that allow adjustment of the rake wheel position.

We recommend fastening support 2 (see point 4) to the A-A1 pairs of holes.

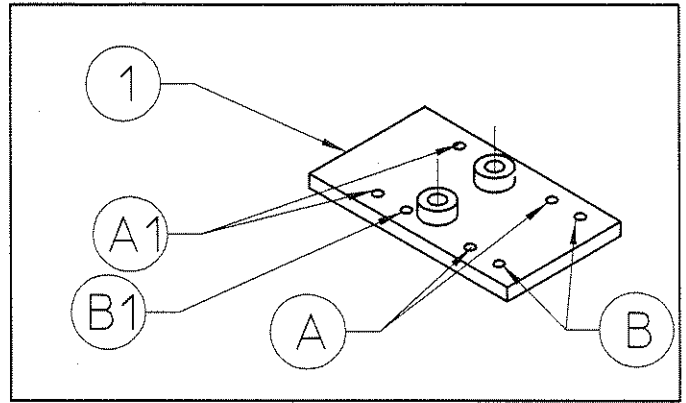

! ATTENTION!!!

3

Place plate 1 against the lower part of the drawbar and fasten it with plate 2 and screws 3.

For positioning, see point 1.

Note : the B pair of holes should be positioned as shown in the drawing.

In this step, you will use:
Item 3: 2 screws M16 x 110
(5/8" x 4 3/8")

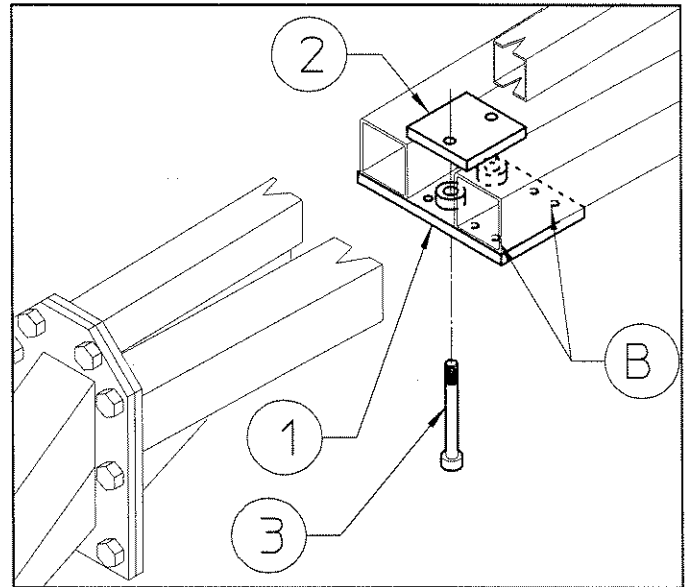

! ATTENTION!!!

4

Attach support 2 to plate 1 using washers 3 - 4 and screws 5.

In this step, you will use:

Item 3: 4 washers $\varnothing 13$ ($\varnothing 1/2$ ")

Item 4: 4 spring washers $\varnothing 13$ ($\varnothing 1/2$ ")

Item 5: 4 screws M12x25
(1/2" x 1")

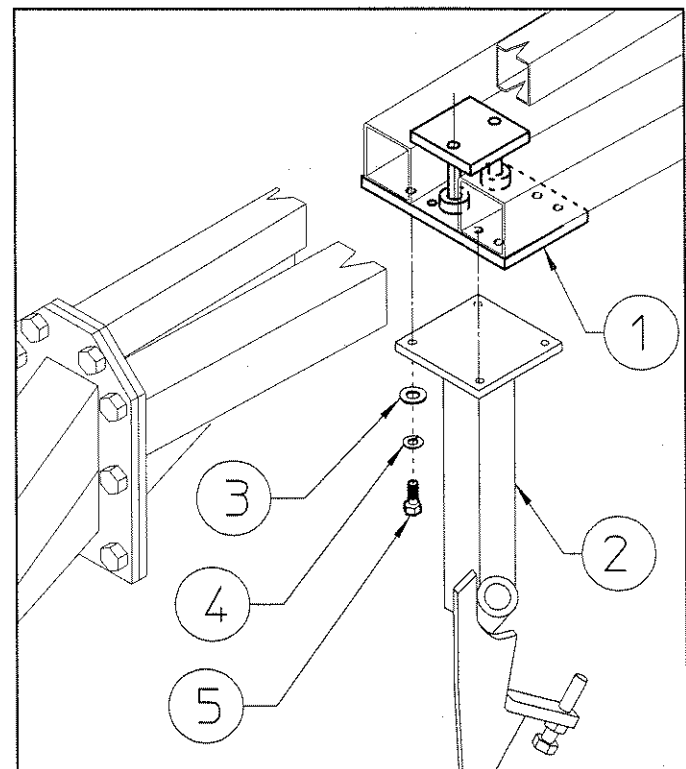

! ATTENTION!!!

5

Mount pulley 1 and bush 2 into bracket 3 using special screws 4 and nuts 5. Repeat these assembling also for rear support.

Place the pulley support 6 against the lower part of the drawbar and fasten it with U bolt 7, washers 8 and nuts 9.

For positioning, see point 1.

In this step, you will use:

Item 4: 2 special screws M12x70 (1/2" x 2 3/4")

Item 5: 2 nuts M12 (1/2")

Item 8: 2 washers $\varnothing 13$ ($\varnothing 1/2$ ")

Item 9: 2 nuts M12 (1/2")

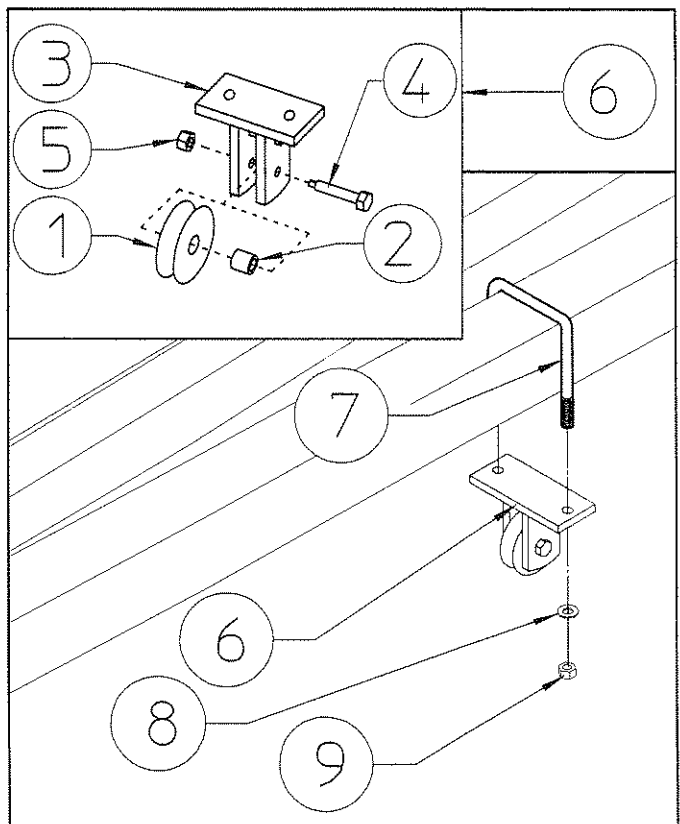

6

Plate 1 has the A-A1 and B-B1 pairs of holes that allow adjustment of the rake wheel position.

We recommend fastening support 2 (see point 7) to the B-B1 pairs of holes.

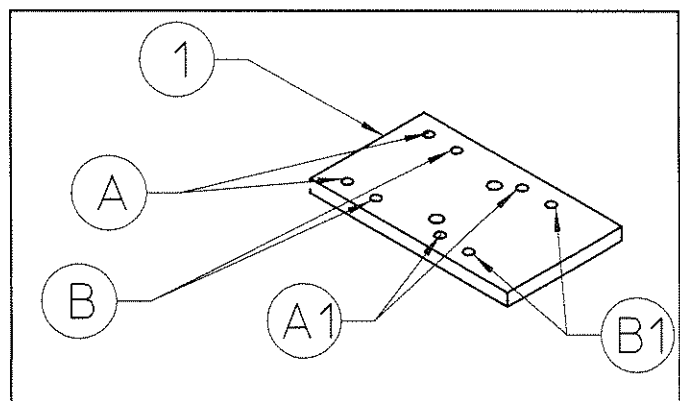

! ATTENTION!!!

7

Place plate 1 against the lower part of the drawbar and fasten it with counterplate 2, washers 3 and screws 4.

For positioning, see point 1.

Note : the B1 pair of holes should must be positioned as shown in the drawing.

In this step, you will use:

Item 3: 2 spring washers $\varnothing 17$ ($\varnothing 11/16$ ")

Item 4: 2 screws M16 x 120 (5/8" x 4 3/4")

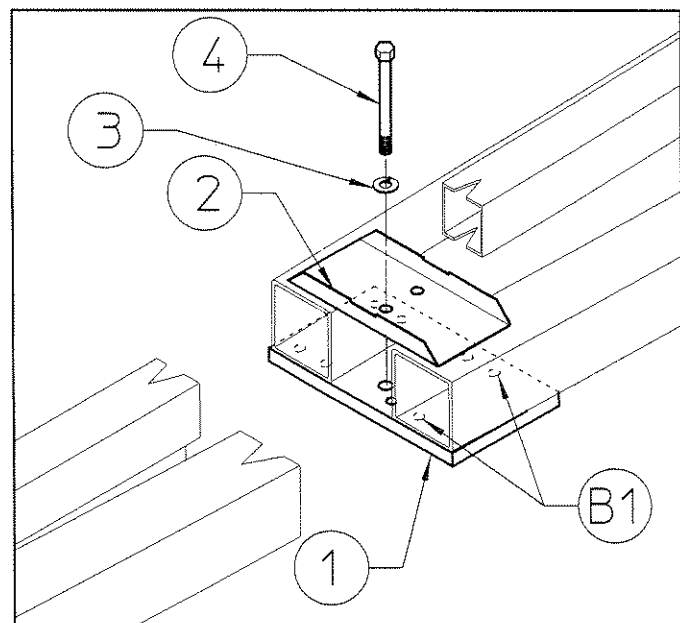



ATTENTION!!!

8

Attach support 2 to plate 1 using washers 3 - 4 and screws 5.

In this step, you will use:

Item 3: 4 washers $\varnothing 13$ ($\varnothing 1/2''$)

Item 4: 4 spring washers $\varnothing 13$ ($\varnothing 1/2''$)

Item 5: 4 screws M12x25 ($1/2'' \times 1''$)

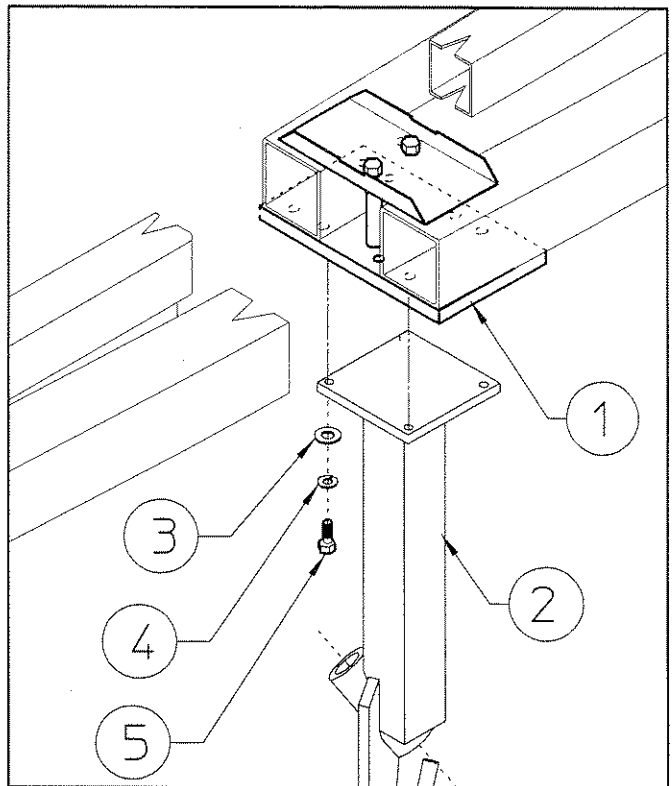

ATTENTION!!!

9

Place the pulley support 1 against the lower part of the drawbar and fasten it with U bolt 2, washers 3 and nuts 4.

For positioning, see point 1.

In this step, you will use:

Item 3: 2 washers $\varnothing 13$ ($\varnothing 1/2''$)

Item 4: 2 nuts M12 ($5/8''$)

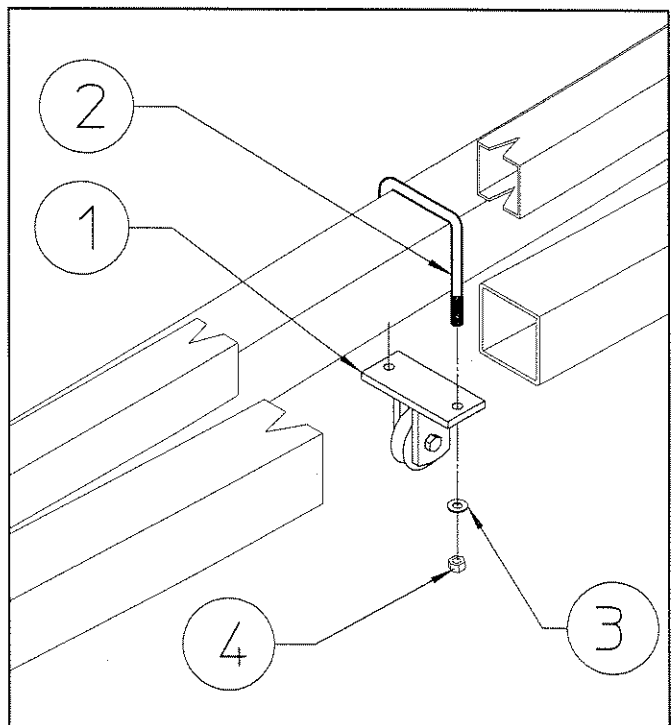

 **ATTENTION!!!**

10

Place plate 1 against the lower part of the drawbar and fasten it with counterplate 2, washers 3 and screws 4.

For positioning, see point 1.

In this step, you will use:

Item 3: 2 spring washers $\varnothing 17$ ($\varnothing 11/16''$)

Item 4: 2 screws M16 x 120 ($5/8'' \times 4 3/4''$)

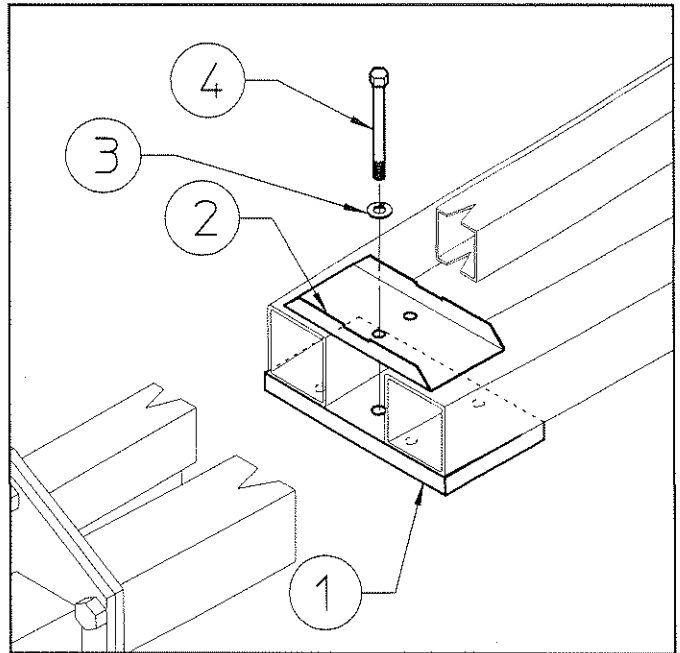

 **ATTENTION!!!**

11

Fasten cylinder 2 to plate 1 using washers 3 and screws 4.

In this step, you will use:

Item 3: 4 spring washers $\varnothing 13$ ($\varnothing 1/2''$)

Item 4: 4 screws M12x30 ($1/2'' \times 1 3/16''$)

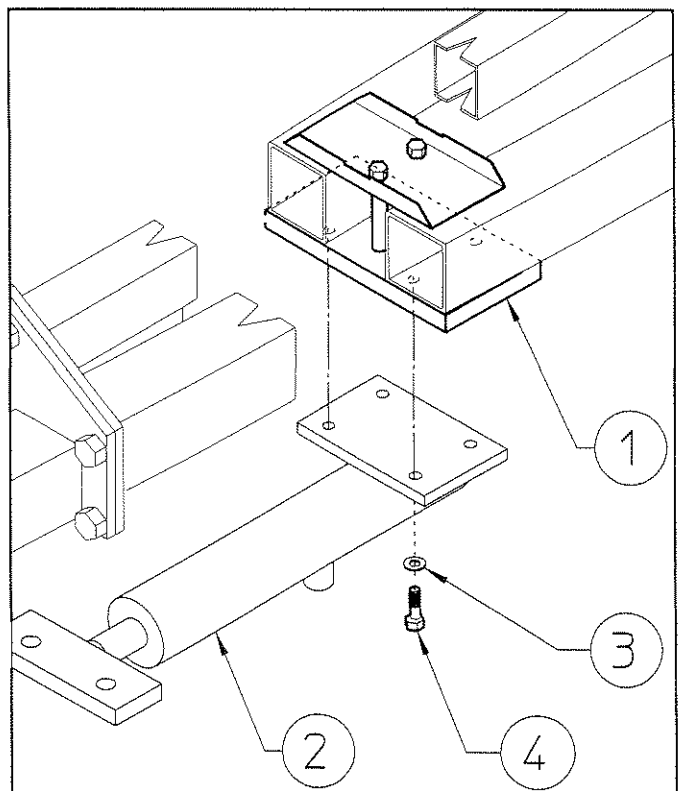

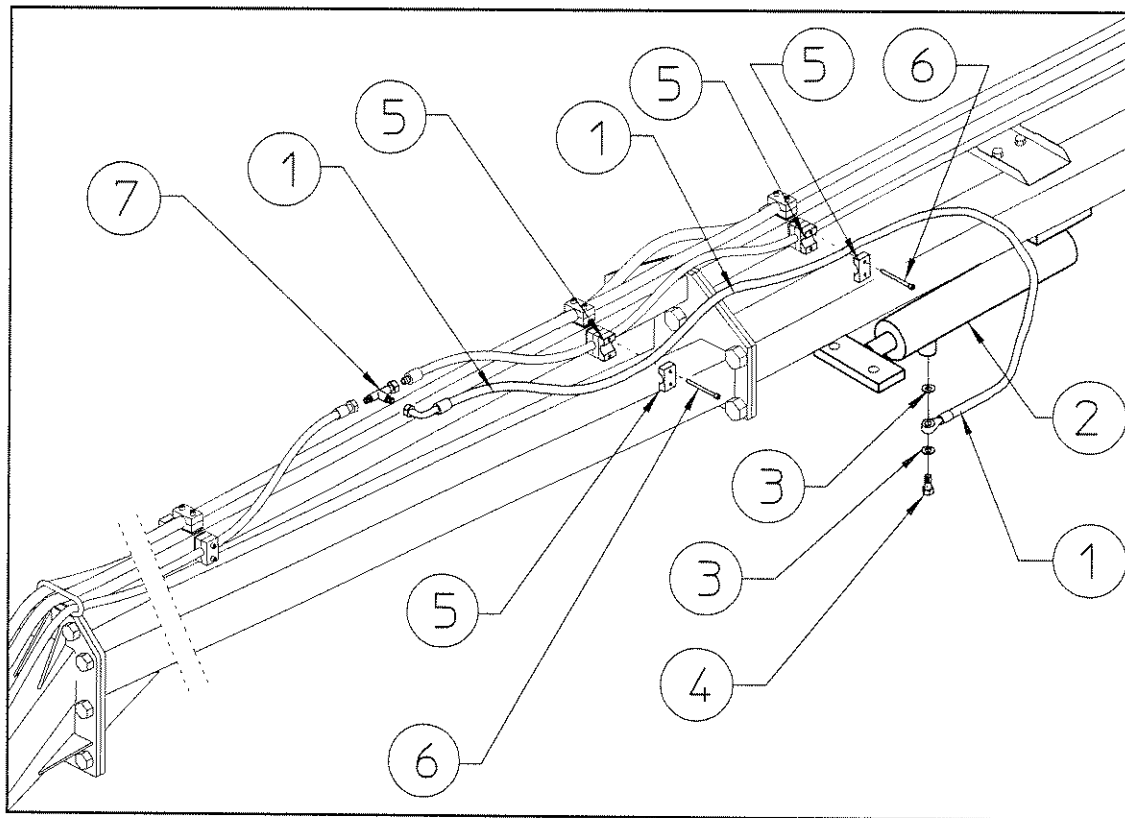

! ATTENTION!!!

1 2

Fasten hose 1 to cylinder 2 using copper washers 3 connector 4.

Secure hose 1 with collars 5 and screws 6.

Connect "T" connector 7 between the two hoses as shown in the drawing.

Connect the curved end of hose 1 to "T" connector 7.

In this step, you will use:

Item 1: 1 hose (3/8") length 1550 (3/8" x 61")

Item 3: 2 copper washers 3/8"

Item 4: 1 screw 3/8"

Item 5: 4 hose collars $\varnothing 18$ ($\varnothing 45/64$ ")

Item 6: 4 hexagon socket head cap screws M6 x 60 ($15/64$ " x $2 \frac{3}{8}$ ")

Item 6:*4 hexagon socket head cap screws M6 x 130 ($15/64$ " x $5 \frac{1}{8}$ ")

Item 7: 1 "T" connector 3/8"

*Use the screws M6 x 130 ($15/64$ " x $5 \frac{1}{8}$ ") if the machine is already with hydraulic rear opening.

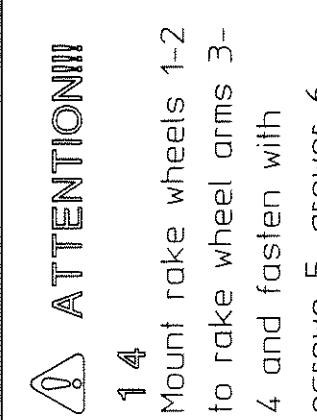
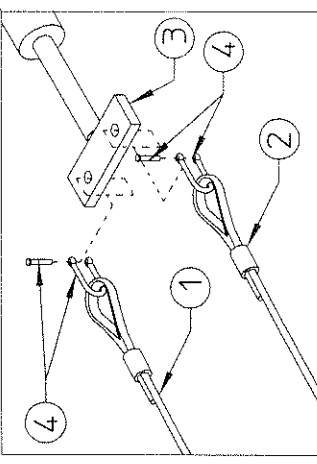
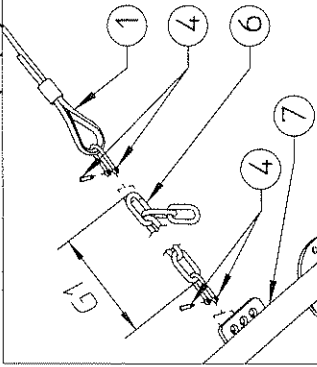
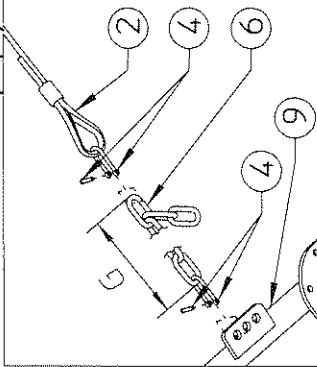
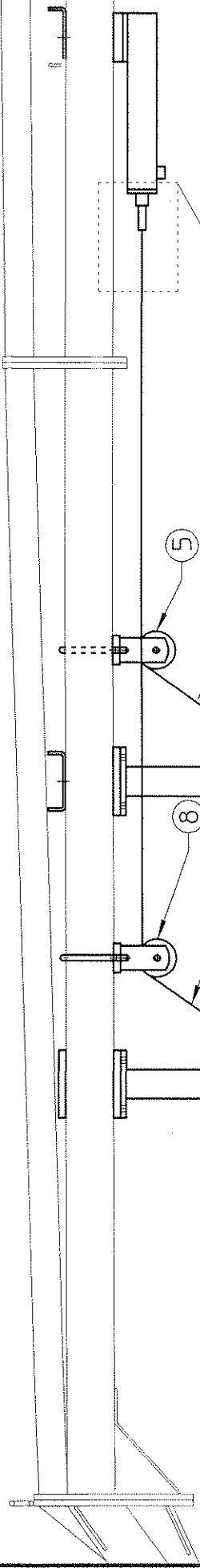

⚠ ATTENTION!!!

- 1 3 Fit cables 1-2 to cylinder 3 by using clamps 4.
- Insert cable 1 on pulley support 5.
- Fit chain 6 to rear wheel support 7 by using clamp 4.
- Connect to indicated rate chain 6 to cable 1 by using clamp 4.
- Insert cable 2 on pulley support 8.
- Fit chain 6 to front wheel support 9 by using clamp 4.
- Connect to indicated rate chain 6 to cable 2 by using clamp 4.

⚠ ATTENTION!!!

- 1 4 Mount rake wheels 1-2 to rake wheel arms 3-4 and fasten with screws 5, grower 6 and nuts 7.

In this step, you will use:

- Item 5:12 screws M10 X 25 (2/64" x 1")
- Item 6:12 growers $\varnothing 10.5-17 \times 2.5$ ($\varnothing 27/64"-11/16" \times 3/16"$)
- Item 7:12 nuts M10 (25/64")

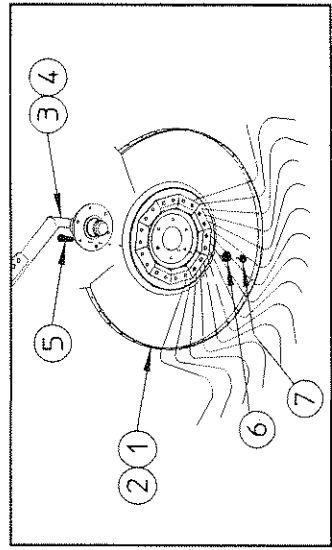

In this step, you will use:

- Item 1: 1 cable lenght 1050 (41 21/64")
- Item 2: 1 cable lenght 1670 (65 47/64")
- Item 4: 6 clamps 5/16"
- Item 5: 2 chain lenght 490 (19 1/2")

Note : G = N° 4 rings of chain
G1= N° 6 rings of chain

ADJUSTMENTS FOR USE

So far we have described how to assemble the central rake wheel standard kit. Should the operator feel the operational results unsatisfactory, we now describe points where adjustments can be made.

A

In order to improve lift, the rake wheels can be moved backwards or forwards compared with the position shown at point 1 and the pulley support 1-2.

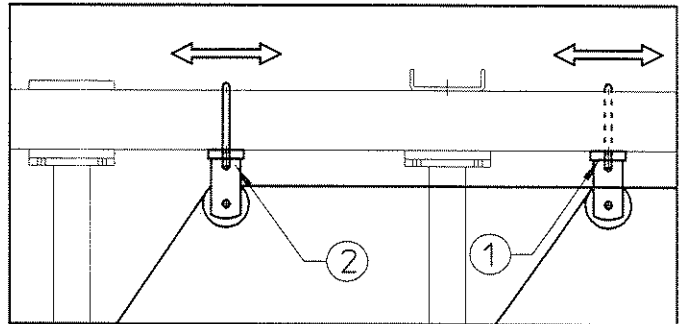

B

The adjusting screw 1 can be used to improve both lift and/or pressure of the rake wheels on the ground. Either of the holes 2 in the arms 2-3 (front-rear) can be used and a different ring in chain 7 from the one shown in point 13 can be attached to cables 5-6 (front-rear).

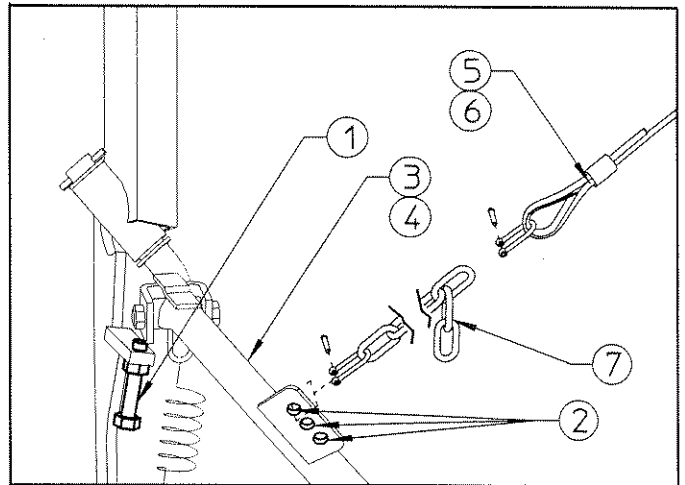

C

In order to increase and decrease interference between the side-delivery rake wheels, various positions can be selected to fasten the rake wheel holder supports (see points 3-7)

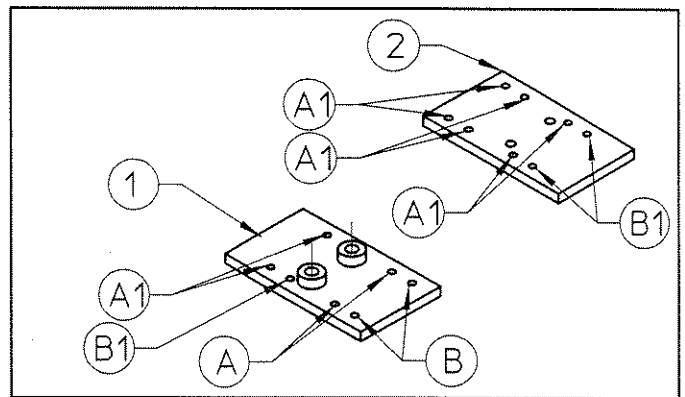

D

In order to ensure that the rake wheels are not lowered during transport, hook chain 1 on to pin 2 and block the cotter pin 3.

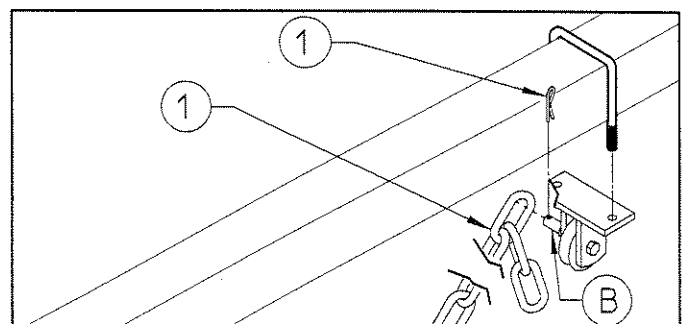



AGRICULTURAL MACHINERY
sitrex® s.r.l.

Zona Industriale-Via L. Pacioti,22
06018 TRESTINA-(Perugia)-ITALY
Tel.(075)8540021-Telefax (075)8540523

