

LELY

ONDERDELENLIJST
PARTS LIST
LISTE DE PIECES DE RECHANGE
ERSATZTEILLISTE

HIBISCUS 421

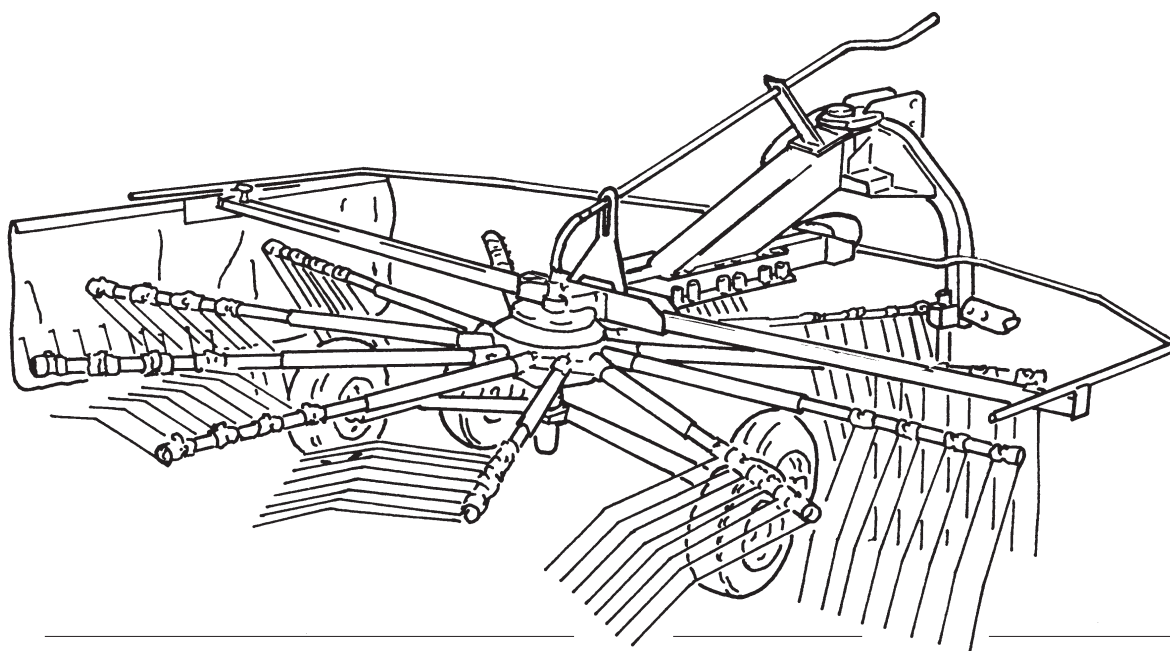

HIBISCUS 421

HIBISCUS	type number type number numéro de type Typennummer	vanaf serienummer as from serial number après numéro série ab Seriennummer
421	4.1042.0000.1	10510 - 0651



ONDERDELEN

Bij het bestellen van onderdelen is het belangrijk dat u het type- en serienummer van uw machine opgeeft. Gebruik alleen originele LELY-onderdelen.

SPARE PARTS

When ordering spare parts, it is important that you indicate the type and serial number of your machine. Use only genuine LELY parts.

PIECES DE RECHANGE

En commandant des pièces de rechange il importe que vous indiquiez les numéros de type et de série de votre machine. N'utiliser que des pièces d'origines LELY.

ERSATZTEILE

Beim Bestellen von Ersatzteilen ist es wichtig, daß Sie die Typ- und Seriennummer Ihrer Maschine angeben.

Nur Original-LELY-Ersatzteile verwenden.

Typ- und Seriennummer in nebenstehende Abbildung eintragen. Bei künftigen Bestellungen haben Sie die Nummer dann griffbereit.

Vul het type- en serienummer hieronder in. Bij toekomstige onderdelenbestellingen heeft u de nummers dan bij de hand.

Complete the box below with the type and serial number.

This is an easy reference with a view to future spare parts ordering.

Veillez noter, ci-dessous, les numéros de type et de serie.

Ceci est important pour toutes commandes de pièces de rechange.

LELY		LELY INDUSTRIES NV		CE
		3155 PD MAASLAND THE NETHERLANDS		
		kg		
Type				
Ser.Nr.				

Verklaring van de in de onderdelenlijst gebruikte tekens.

Explanation of signs used in the parts list.

Explication des signes qui figurent dans la liste des pièces.

Erklärung der in der Ersatzteilliste verwendeten Zeichen.

[R] = RECHTSE UITVOERING
RH VERSION

[L] = LINKSE UITVOERING
LH VERSION

Onder rechtse of linkse uitvoering wordt de plaats van het onderdeel verstaan, gezien van de achterzijde van de machine.

By RH or LH version the position of the part is meant, seen from the rear of the machine

[RD] = RECHTSOM DRAAIENDE UITVOERING
RH ROTATING VERSION

[LD] = LINKSOM DRAAIENDE UITVOERING
LH ROTATING VERSION

Onder rechtson of linksom draaiende uitvoering wordt de draairichting van het onderdeel verstaan, gezien van de bovenzijde van de machine.

By RH or LH rotating version the sense of rotating of the part is meant, seen from the top of the machine.

[x] = ONDERDEEL WORDT NIET GETOOND
PART IS NOT SHOWN

Bijvoorbeeld linkse uitvoering overeenkomstig de wel getekende rechtse uitvoering.

E.g. : LH version is similar to the RH version, which is actually shown.

[#] = NIET LOS LEVERBAAR
NOT AVAILABLE SEPARATELY

~ = AANTAL (INDIEN NODIG) AFHANKELIJK VAN INBOUWMAAT
QUANTITY (IF APPLICABLE) DEPENDING UPON ASSEMBLY

[—] = SLUITRING

[—/—] = VEERRING

[####] = TANDVEERRING

[>|<] = OLIEKEERRING

[T+T] = TANDWIELSET

[D+D] = VULRINGSET

[A+A] = SET AFDICHTINGSRINGEN

WASHER

SPRING WASHER

SHAKE-PROOF WASHER

OIL SEAL

PAIR OF GEARS

SHIM SET

SET OF SEALING RINGS

VERSION DROITE
RECHTE AUSFÜHRUNG

VERSION GAUCHE
LINKE AUSFÜHRUNG

Par version droite ou gauche on entend la position de la pièce, vue de l'arrière de la machine.

Die Verweisungen "rechte Ausführung" oder "linke Ausführung" geben die Position des Teils, von der Hinterseite der Maschine aus gesehen, an.

VERSION ROTATION A DROITE
RECHTSUMDREHENDE AUSFÜHRUNG

VERSION ROTATION A GAUCHE
LINKSUMDREHENDE AUSFÜHRUNG

Version rotation à droit: ceci correspond au sens de rotation de la pièce, vue du dessus la machine.

Mit diesen Verweisungen wird die Drehrichtung des Teils von der Oberseite der Maschine aus gesehen, angegeben.

PIECE N'EST PAS MONTÉE
TEIL WIRD NICHT GEZEIGT

Exemple : la version gauche est représentée. La version droite correspond à la version gauche, mais n'est pas représentée.

Beispiel : die linke Ausführung entspricht der effektiv gezeigten Rechten.

VENDU EN KIT UNIQUEMENT
NICHT SEPARAT LIEFERBAR

QUANTITE (SI NÉCESSAIRE) EN FONCTION DU MONTAGE
ANZAHL VOM EINBAUMASS ABHÄNGIG (WENN ERFORDERLICH)

RONDELLE PLATE

RONDELLE GROWER

RONDELLE EVENTAIL

ETANCHEITE

JEU D'ENGRENAGES

JEU D'ÉPAISSEURS

JEU D'ANNEAUX D'ETANCHEITE

UNTERLEGSCHIEBE

FEDERRING

RÄNDELFEDEERING

ÖLDICHTUNGSRING

ZAHNRÄDERSATZ

PASSSCHEIBENSATZ

DICHTUNGSRINGENSATZ

HIBISCUS 421

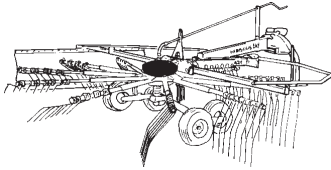

Centrale aandrijving
Central drive
Entraînement central
Zentralantrieb

01

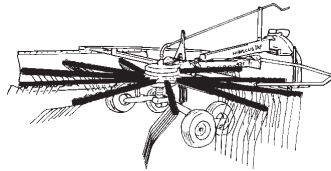

Tandbevestiging
Tine fixation
Fixation des dents
Zinkenbefestigung

02

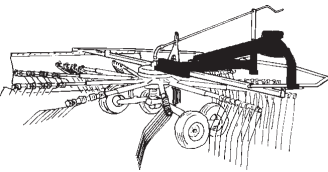

Driepuntsbok
Headstock
Tête d'attelage
Dreipunktturm

03

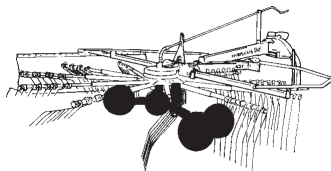

Loopwielen
Support wheels
Roues de support
Stützräder

04

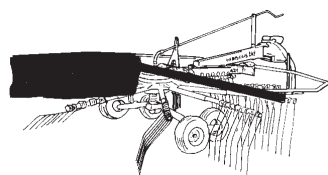

Geleidebord
Deflecteur
Panneau de guidage
Führungsschild

05

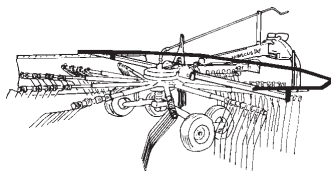

Beveiligingsfreems
Safety frames
Châssis de Sécurité
Sicherheitsramen

05

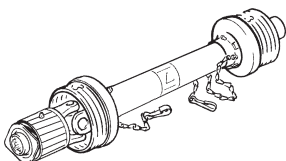

Koppelingsas
PTO shaft
Arbre de transmission
Gelenkwelle

06

LELY

HIBISCUS	type number type number numéro de type Typnummer	vanaf serienummer as from serial number après numéro de série ab Seriennummer
421	4.1042.0000A1	10405 - 0501
421	4.1042.0000.1	10413 - 0501

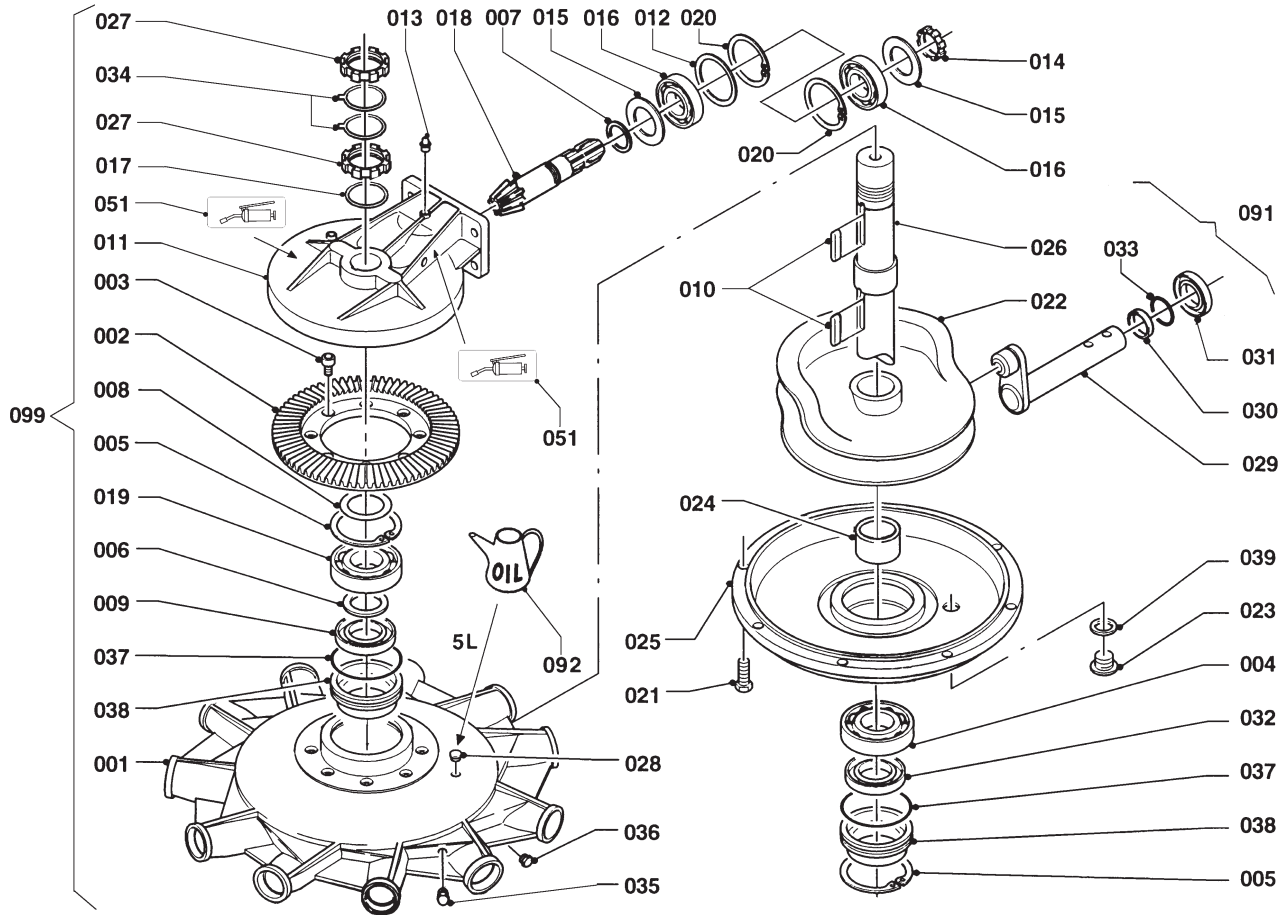
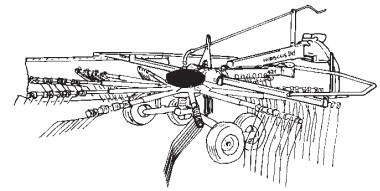

B075.03.10

REF.	ONDERDEELNR. PART NUMBER REFERENCE TEILNUMMER	AANTAL QUANTITY QUANTITE ANZAHL
------	--	--

001	0.792.0300.00	1
002	0.792.6201.00	1
003	9.1057.0009.1	8
004	8.0.1.00173	1
005	9.1120.0016.1	2
006	0.712.7525.00	1
007	0.244.7510.00	1
008	0.712.7500.00	1
009	8.7.1.00783	1
010	9.1071.0017.2	2
011	0.792.1712.00	1
012	0.267.7500.00	1
013	8.8.3.00325	1
014	0.278.7103.00	1
015	8.3.0.00394	2
016	8.0.9.00024	2
017	0.177.7505.00	1
018	0.792.5201.00	1
019	8.0.1.01930	1
020	8.5.2.00030	2
021	0.792.7002.00	11
022	0.792.0301.00	1
023	8.6.8.01931	1
024	0.792.7102.00	1
025	0.792.1700.00	1

REF.	ONDERDEELNR. PART NUMBER REFERENCE TEILNUMMER	AANTAL QUANTITY QUANTITE ANZAHL
------	--	--

026	0.792.3721.00	1
027	8.2.5.00176	2
028	8.6.6.01266	1
029	2.792.7121.00	11
030	0.789.7144.00	11
031	8.7.3.01239	11
032	8.7.1.01097	1
033	0.792.7510.00	11
034	8.3.8.00336	2
035	8.6.5.00203	1
036	8.6.6.00088	1
037	8.7.6.00974	2
038	0.792.1301.00	2
039	8.3.0.01353	1
051	9.1170.0205.0	2
091	9.1083.0029.2	1
092	9.1171.0042.4	(5L)
099	4.1042.0000.2	1

[>|<]

[>|<]

[>|<]

[>|<]

[>|<]

[>|<]

[>|<]

[>|<]

[>|<]

[>|<]

[>|<]

[>|<]

[>|<]

[>|<]

[>|<]

[>|<]

[>|<]

[>|<]

[>|<]

[>|<]

[>|<]

[>|<]

[>|<]

[>|<]

[>|<]

[>|<]

[>|<]

[>|<]

LELY

HIBISCUS	type number type number numéro de type Typnummer	vanaf serienummer as from serial number après numéro de serie ab Seriennummer
421	4.1042.0000.1	10510 - 0651

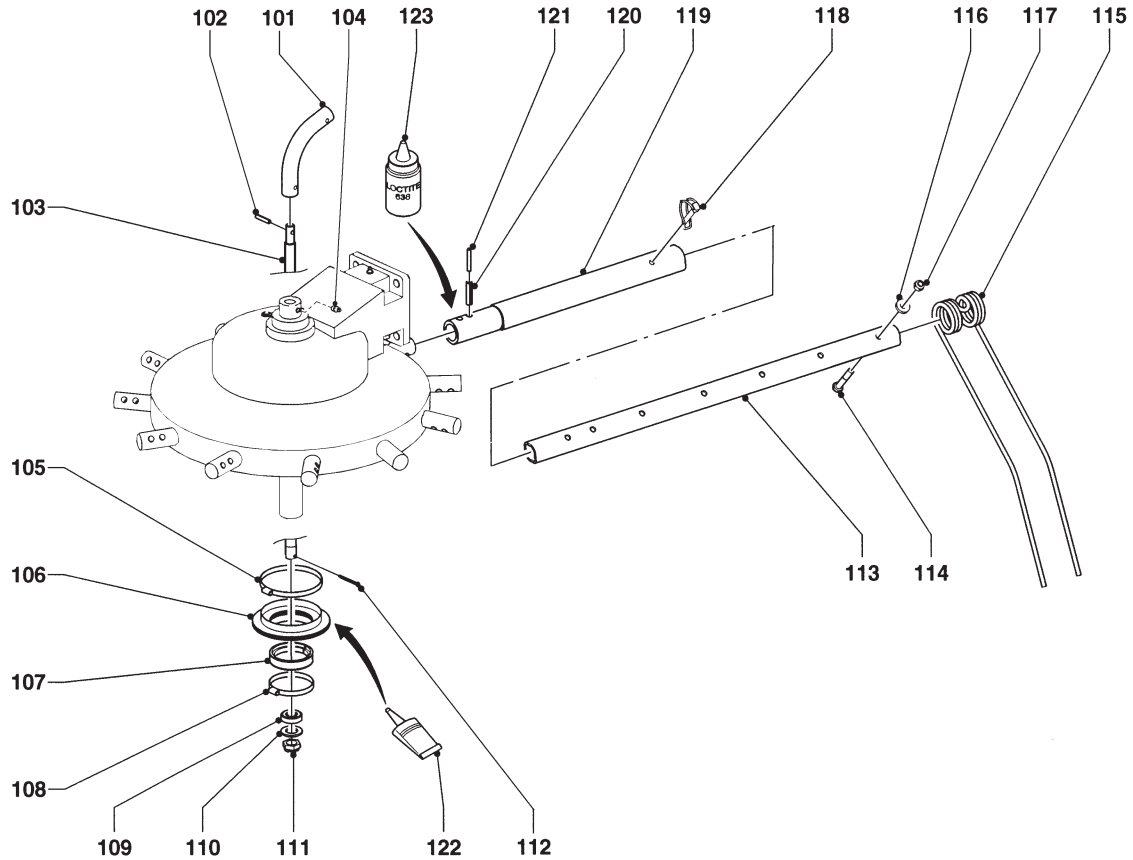
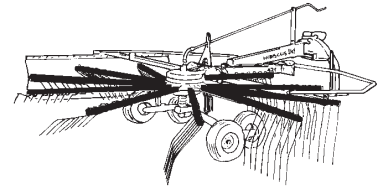

B201.01.20

REF.	ONDERDEELNR. PART NUMBER REFERENCE TEILNUMMER	AANTAL QUANTITY QUANTITE ANZAHL
------	--	--

101	4.1042.1060.0	1	
102	9.1070.0023.2	2	Ø8x50 DIN 1481
103	4.1042.1340.0	1	
104	9.1068.0007*2	1	AM 8x1,25
105	9.1066.0027.3	1	Ø120-Ø140
106	9.1161.0032.4	1	
107	4.1042.1057.0	1	
108	9.1066.0010*0	1	Ø70-Ø90
109	9.1006.0002.3	1	AKN E403-025
110	9.1048.0045*4	1	26 DIN 126 [—]
111	9.1031.0014.4	1	M22x1,5 DIN 937-22H
112	9.1072.0007.5	1	5x45 DIN 94
113	4.1042.1356.0	11	
114	9.1113.0059*2	44	M12x70 DIN 931-8.8
115	4.1042.1390.0	44	
116	9.1048.0079*3	44	13 DIN 7349 [—]
117	9.1030.0013*4	44	M12 DIN 985-8
118	4.1042.1498.0	11	
119	4.1042.0570.0	11	
120	9.1070.0030.2	22	Ø12x50 DIN 1481
121	9.1070.0076.6	22	Ø7x50 DIN 1481
122	[#]	50 gr	MOLYKOTE BR2 PLUS
123	9.1126.0012.5	50 ml	LOCTITE 638

REF.	ONDERDEELNR. PART NUMBER REFERENCE TEILNUMMER	AANTAL QUANTITY QUANTITE ANZAHL
------	--	--

LELY

HIBISCUS	type number type number numéro de type Typnummer	vanaf serienummer as from serial number après numéro de série ab Seriennummer
421	4.1042.0000A1	10405 - 0501
421	4.1042.0000.1	10413 - 0501

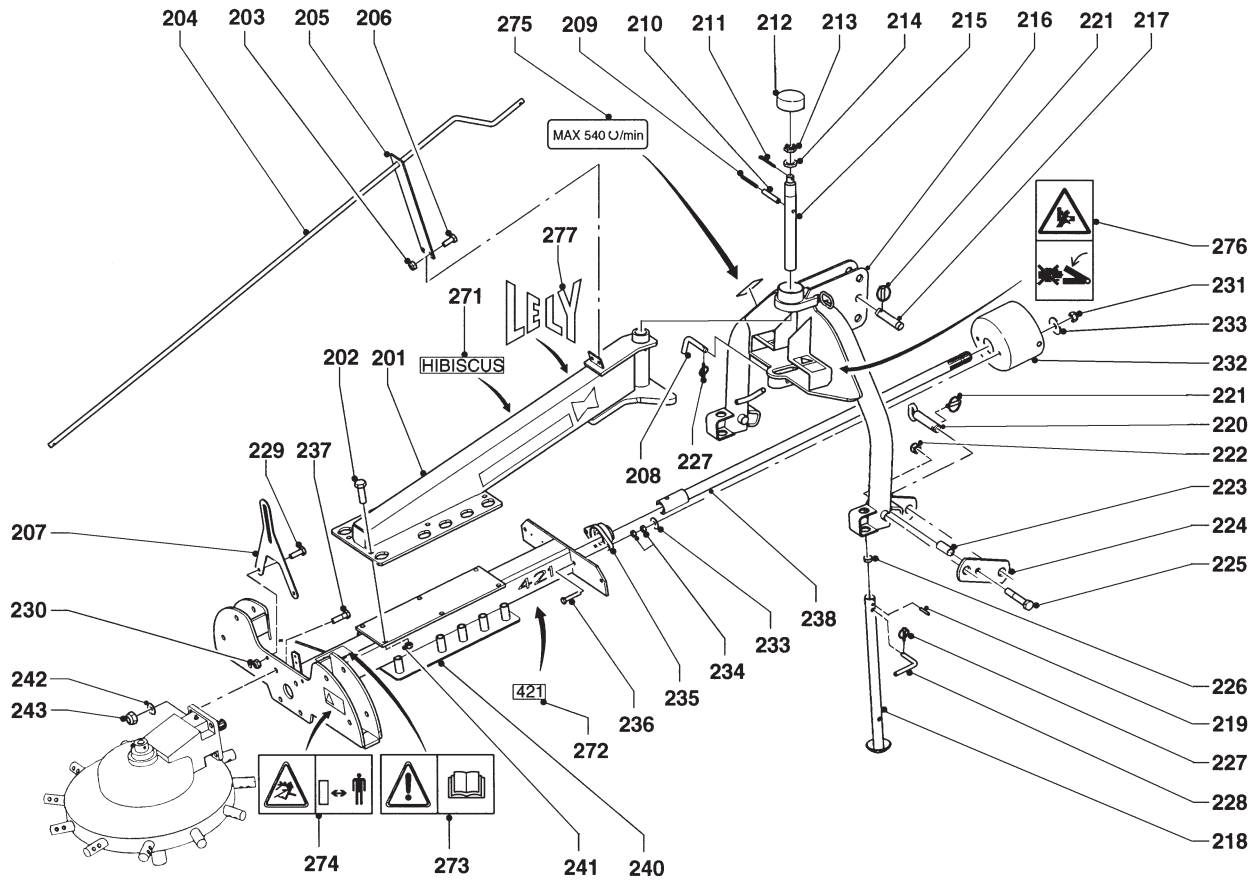
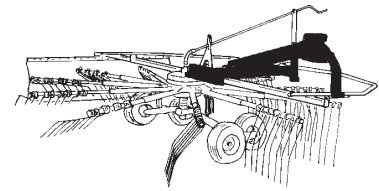

B202.01.10

REF.	ONDERDEELNR. PART NUMBER REFERENCE TEILNUMMER	AANTAL QUANTITY QUANTITE ANZAHL
------	--	--

201	4.1042.1300.0	1
202	9.1113.0069*5	6 M14x45 DIN 933-8.8
203	9.1030.0012*3	2 M8 DIN 985-8
204	4.1042.1055.0	1
205	4.1042.1056.0	1
206	9.1113.0128*1	2 M8x25 DIN 933 8.8
207	4.1042.1054.0	1
208	4.1003.0142.0	1
209	9.1070.0042.0	1 Ø6x60 DIN 1481
210	9.1070.0028.0	1 Ø10x60 DIN 1481
211	9.1072.0007.5	1 5x45 DIN 94
212	9.1108.0095.2	1
213	9.1031.0004.1	1 M24x1,5 DIN 937-22H
214	9.1048.0097.0	1 A26 DIN 7989 []
215	4.1035.1249.0	1
216	4.1035.1250.0	1
217	9.1088.0005.1	1 25x95
218	4.1017.0141.0	2
219	9.1070.0023.2	2 Ø8x50 DIN 1481
220	1.1804.0310.0	2
221	9.1123.0002*5	3 Ø11
222	9.1130.0017*1	2 M20 DIN 985-8
223	4.1016.0818.0	2
224	4.1025.0819.0	4
225	9.1113.0097*5	2 M20x120 DIN 931-8.8

REF.	ONDERDEELNR. PART NUMBER REFERENCE TEILNUMMER	AANTAL QUANTITY QUANTITE ANZAHL
------	--	--

226	9.1108.0021.4	2
227	9.1123.0003*6	3 Ø6
228	4.1016.0298.0	2
229	9.1113.0120*0	2 M10x30 DIN 933-8.8
230	9.1030.0004*2	2 M10 DIN 985-8
231	9.1030.0024*1	2 M12 DIN 985-10
232	4.1042.1499.0	1
233	9.1048.0041*0	4 A13 DIN 9021 []
234	9.1029.0010.2	4 M12 DIN 934-12
235	9.1008.0018.3	1 FYTB 35 FM
236	9.1113.0057*0	2 M12x60 DIN 931-8.8
237	9.1057.0063.6	4 M16x40 DIN 912-A2
238	4.1042.1020.0	1
240	4.1042.1000.0	1
241	9.1030.0015*6	6 M14 DIN 985-8
242	9.1048.0015*2	4 A17 DIN 125 []
243	9.1030.0014*5	4 M16 DIN 985-8
271	9.1170.0448.5	2 "HIBISCUS"
272	9.1170.0452.2	2 "421"
273	9.1170.0408.0	1
274	9.1170.0410.2	1
275	9.1170.0125.4	1 "MAX 540/min"
276	9.1170.0437.1	2
277	9.1170.0200.2	2 "LELY"



HIBISCUS	type number type number numéro de type Typnummer	vanaf serienummer as from serial number après numéro de série ab Seriennummer
421	4.1042.0000.1	10510 - 0651

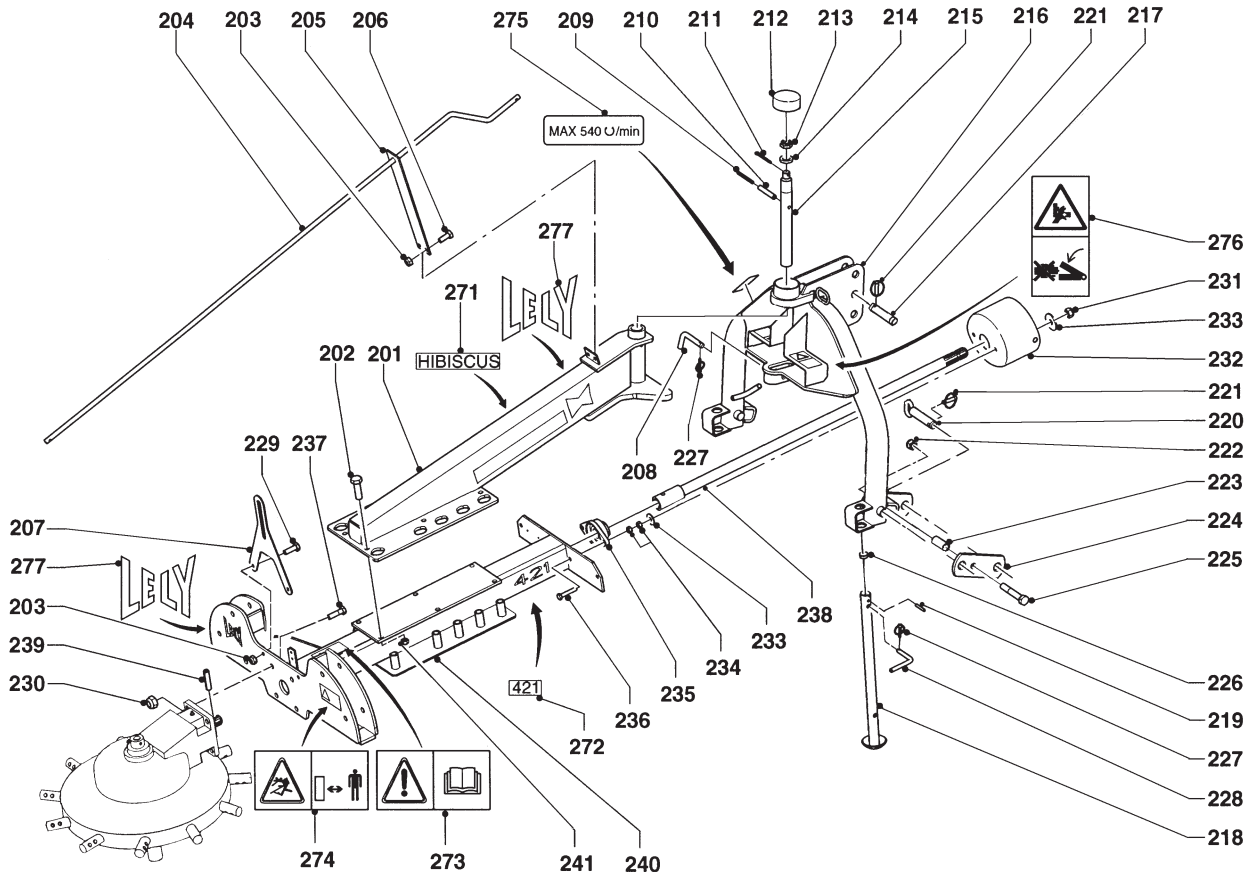
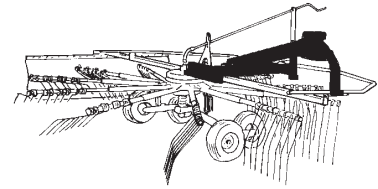

B202.01.20

REF.	ONDERDEELNR. PART NUMBER REFERENCE TEILNUMMER	AANTAL QUANTITY QUANTITE ANZAHL
------	--	--

201	4.1042.1300.0	1
202	9.1113.0069*5	6 M14x45 DIN 933-8.8
203	9.1030.0004*2	4 M10 DIN 985-8
204	4.1042.1055.0	1
205	4.1042.1056.0	1
206	9.1113.0029*0	2 M10x25 DIN 933 8.8
207	4.1042.1054.0	1
208	4.1003.0142.0	1
209	9.1070.0042.0	1 Ø6x60 DIN 1481
210	9.1070.0028.0	1 Ø10x60 DIN 1481
211	9.1072.0007.5	1 5x45 DIN 94
212	9.1108.0095.2	1
213	9.1031.0004.1	1 M24x1,5 DIN 937-22H
214	9.1048.0097.0	1 A26 DIN 7989 [—]
215	4.1035.1249.0	1
216	4.1035.1250.0	1
217	9.1088.0005.1	1 25x95
218	4.1017.0141.0	2
219	9.1070.0023.2	2 Ø8x50 DIN 1481
220	1.1804.0310.0	2
221	9.1123.0002*5	3 Ø11
222	9.1130.0017*1	2 M20 DIN 985-8
223	4.1016.0818.0	2
224	4.1025.0819.0	4
225	9.1113.0097*5	2 M20x120 DIN 931-8.8

REF.	ONDERDEELNR. PART NUMBER REFERENCE TEILNUMMER	AANTAL QUANTITY QUANTITE ANZAHL
------	--	--

226	9.1108.0021.4	2
227	9.1123.0003*6	3 Ø6
228	4.1016.0298.0	2
229	9.1113.0120*0	2 M10x30 DIN 933-8.8
230	9.1030.0014*5	4 M16 DIN 985-8
231	9.1030.0013*4	2 M12 DIN 985-8
232	4.1042.1499.0	1
233	9.1048.0041*0	4 A13 DIN 9021 [—]
234	9.1029.0008*3	4 M12 DIN 934-8
235	9.1008.0018.3	1 FYTB 35 FM
236	9.1113.0177.1	2 M12x65 DIN 933-A2-2 RVS
237	9.1113.0159*4	4 M16x55 DIN 931-8.8
238	4.1042.1021.0	1
239	9.1070.0030.2	1 Ø12x50 DIN 1481
240	4.1042.1000.0	1
241	9.1030.0015*6	6 M14 DIN 985-8
271	9.1170.0448.5	2 "HIBISCUS"
272	9.1170.0452.2	2 "421"
273	9.1170.0408.0	1
274	9.1170.0410.2	1
275	9.1170.0125.4	1 "MAX 540/min"
276	9.1170.0437.1	2
277	9.1170.0200.2	3 "LELY"

LELY

HIBISCUS	type number type number numéro de type Typnummer	vanaf serienummer as from serial number après numéro de serie ab Seriennummer
421	4.1042.0000A1	10405 - 0501
421	4.1042.0000.1	10413 - 0501

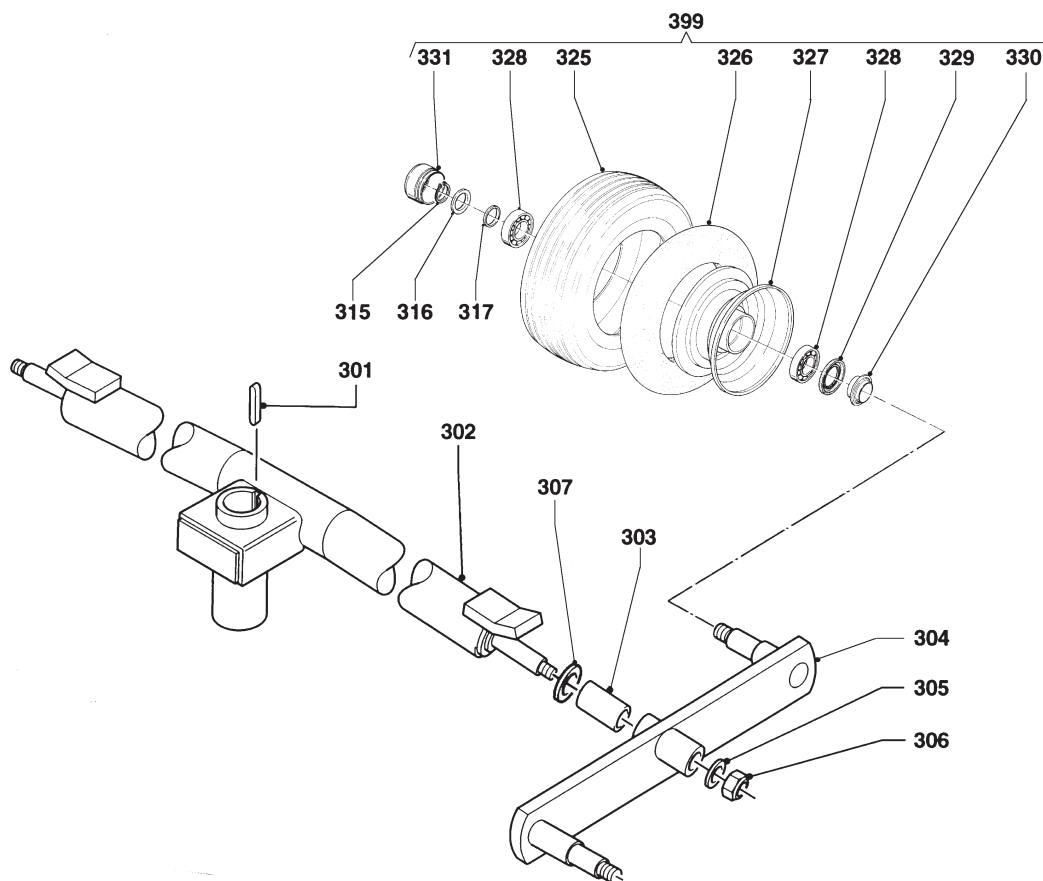
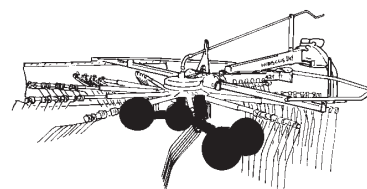

B078.02.10

REF.	ONDERDEELNR. PART NUMBER REFERENCE TEILNUMMER	AANTAL QUANTITY QUANTITE ANZAHL	
------	--	--	--

301	4.1037.1338.0	2	A10x8x110
302	4.1042.0120.0	1	
303	4.1042.0106.0	2	
304	4.1042.0110.0	1	[R]
	4.1042.0180.0	1	[L][x]
305	9.1048.0043*2	2	17 DIN 7349 [—]
306	9.1030.0014*5	2	M16 DIN 985-8
307	9.1048.0022*2	2	A 28 DIN 125 [—]
315	9.1119.0022.1	4	25x2 DIN 471
316	9.1052.0007.4	4	S25x35x2 DIN 988
317	4.1011.0066.0	4	
325	9.1110.0023.4	(1)	16x6,50x8 2,75 BAR
326	9.1111.0017.4	(1)	16x6,50-8 TR13
327	9.1102.0024.6	(1)	5,50Ax8 (Cpl.= 399)
328	9.1001.0081.3	(2)	6205 2RS1
329	9.1106.0014.6	(1)	
330	9.1106.0015.0	(1)	
331	9.1041.0104.0	(1)	Ø52x32

REF.	ONDERDEELNR. PART NUMBER REFERENCE TEILNUMMER	AANTAL QUANTITY QUANTITE ANZAHL	
------	--	--	--

399	4.1033.0920.0	4	= REF. 325-331
-----	---------------	---	----------------



HIBISCUS	type number type number numéro de type Typnummer	vanaf serienummer as from serial number après numéro de serie ab Seriennummer
421	4.1042.0000.1	10510 - 0651

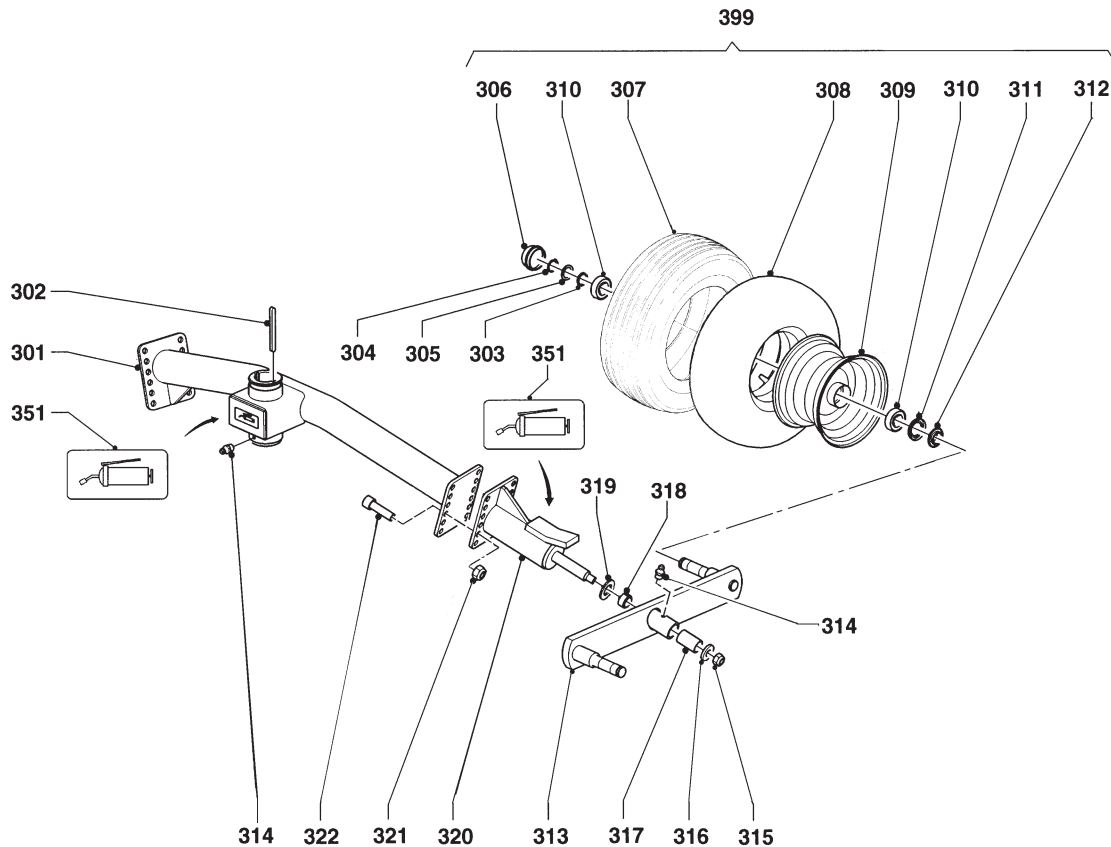
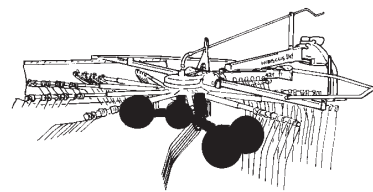

B203.01.10

REF.	ONDERDEELNR. PART NUMBER REFERENCE TEILNUMMER	AANTAL QUANTITY QUANTITE ANZAHL
------	--	--

301	4.1042.0121.0	1
302	9.1071.0054.4	2
303	4.1011.0066.0	4
304	9.1119.0022.1	4
305	9.1052.0007*4	4
306	9.1041.0104.0	(1)
307	9.1110.0023.4	(1)
308	9.1111.0017.4	(1)
309	9.1102.0024.6	(1)
310	9.1001.0081.3	(2)
311	9.1106.0014.6	(1)
312	9.1106.0015.0	(1)
313	4.1042.0110.0	1
	4.1042.0180.0	1
314	9.1068.0007*2	3
315	9.1030.0014*5	2
316	9.1048.0043*2	2
317	4.1042.0107.0	2
318	9.1077.0007.0	4
319	9.1048.0022*2	2
320	4.1042.1360.0	2
321	9.1030.0013*4	12
322	9.1057.0077.6	12
351	9.1170.0205.0	3

REF.	ONDERDEELNR. PART NUMBER REFERENCE TEILNUMMER	AANTAL QUANTITY QUANTITE ANZAHL
------	--	--

399	4.1033.0920.0	4 = REF. 306-312
-----	---------------	------------------

A10x8x110 DIN 6885
25x2 DIN 471
S25x35x2 DIN 988 [—]
Ø52x32
16x6,50x8 2,75 BAR
16x6,50-8 TR13
5,50Ax8 (Cpl.= 399)
6205 2RS1
[R]
[L][x]
AM 8x1,25
M16 DIN 985-8
17 DIN 7349 [—]
EG 25/32x16 DIN 1498
A 28 DIN 125 [—]
M12 DIN 985-8
M12x40 DIN 912-8.8
"Smeerpunt"
"Greasing point"
"Point de graissage"
"Schmierstelle"



HIBISCUS	type number type number numéro de type Typnummer	vanaf serienummer as from serial number après numéro de série ab Seriennummer
421	4.1042.0000A1	10405 - 0501
421	4.1042.0000.1	10413 - 0501

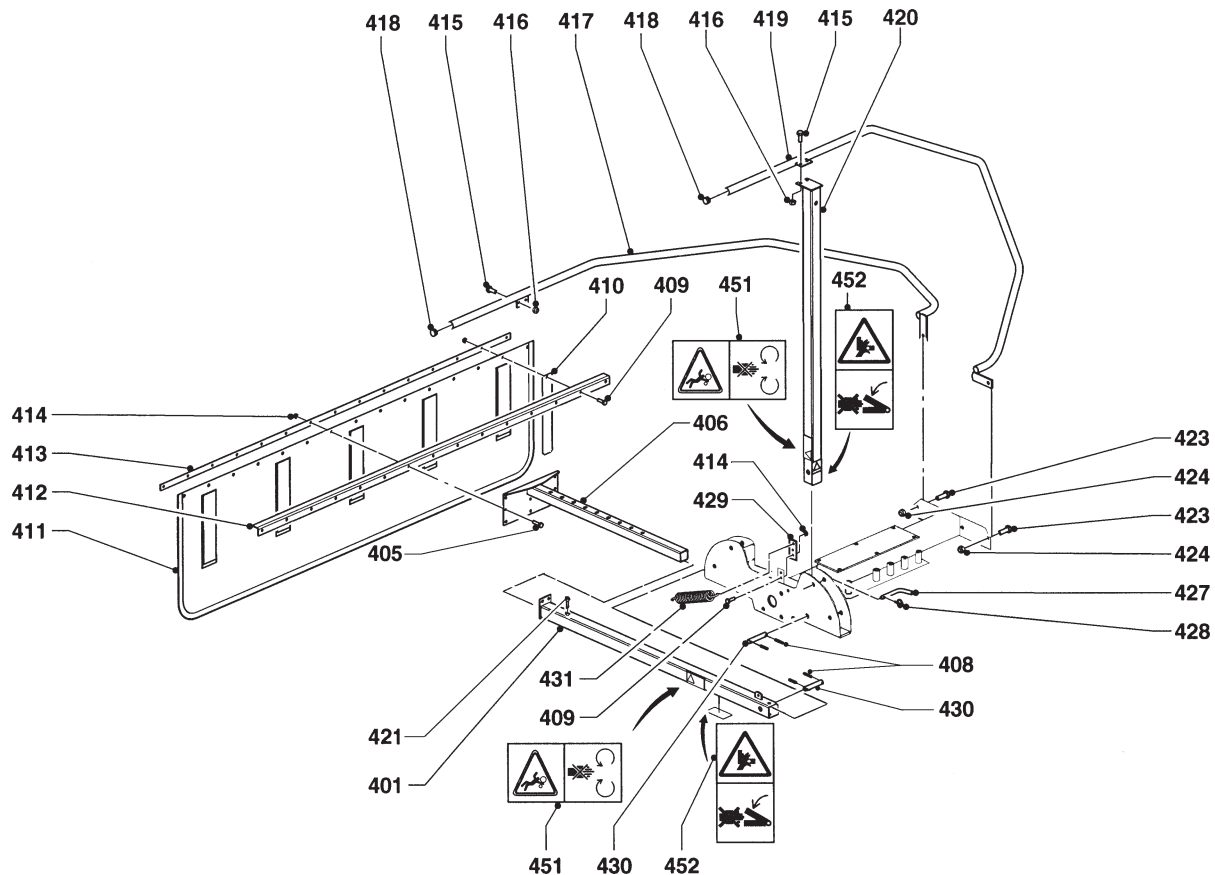
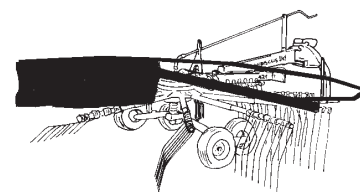

B204.01.10

REF.	ONDERDEELNR. PART NUMBER REFERENCE TEILNUMMER	AANTAL QUANTITY QUANTITE ANZAHL	
------	--	--	--

401	4.1042.1100.0	1	[L]
405	9.1113.0130*3	3	M8x30 DIN 933-8.8
406	4.1042.1120.0	1	
408	9.1070.0017.3	4	Ø6x30 DIN 1481
409	9.1058.0009*0	14	M8x30 DIN 603-4,6
410	4.1042.1503.0	5	
411	4.1042.1500.0	1	
412	4.1042.1501.0	1	
413	4.1042.1502.0	1	
414	9.1030.0012*3	17	M8 DIN 985-8
415	9.1113.0029*0	4	M10x25 DIN 933-8.8
416	9.1030.0004*2	4	M10 DIN 985-8
417	4.1042.1080.0	1	[L]
418	9.1108.0085.6	2	Ø32
419	4.1042.1090.0	1	[R]
420	4.1042.1110.0	1	[R]
421	9.1141.0009.1	1	M10x35 DIN 6336
423	9.1113.0125*5	2	M12x35 DIN 933-8.8
424	9.1030.0024*1	2	M12 DIN 985-10
427	4.1003.0142.0	2	
428	9.1123.0003*6	2	Ø6
429	4.1042.1053.0	1	
430	4.1042.1220.0	2	
431	1.1633.1496.0	1	

REF.	ONDERDEELNR. PART NUMBER REFERENCE TEILNUMMER	AANTAL QUANTITY QUANTITE ANZAHL	
------	--	--	--

451	9.1170.0407.6	2	
452	9.1170.0437.1	2	

LELY

HIBISCUS	type number type number numéro de type Typnummer	vanaf serienummer as from serial number après numéro de série ab Seriennummer
421	4.1042.0000.1	10510 - 0651

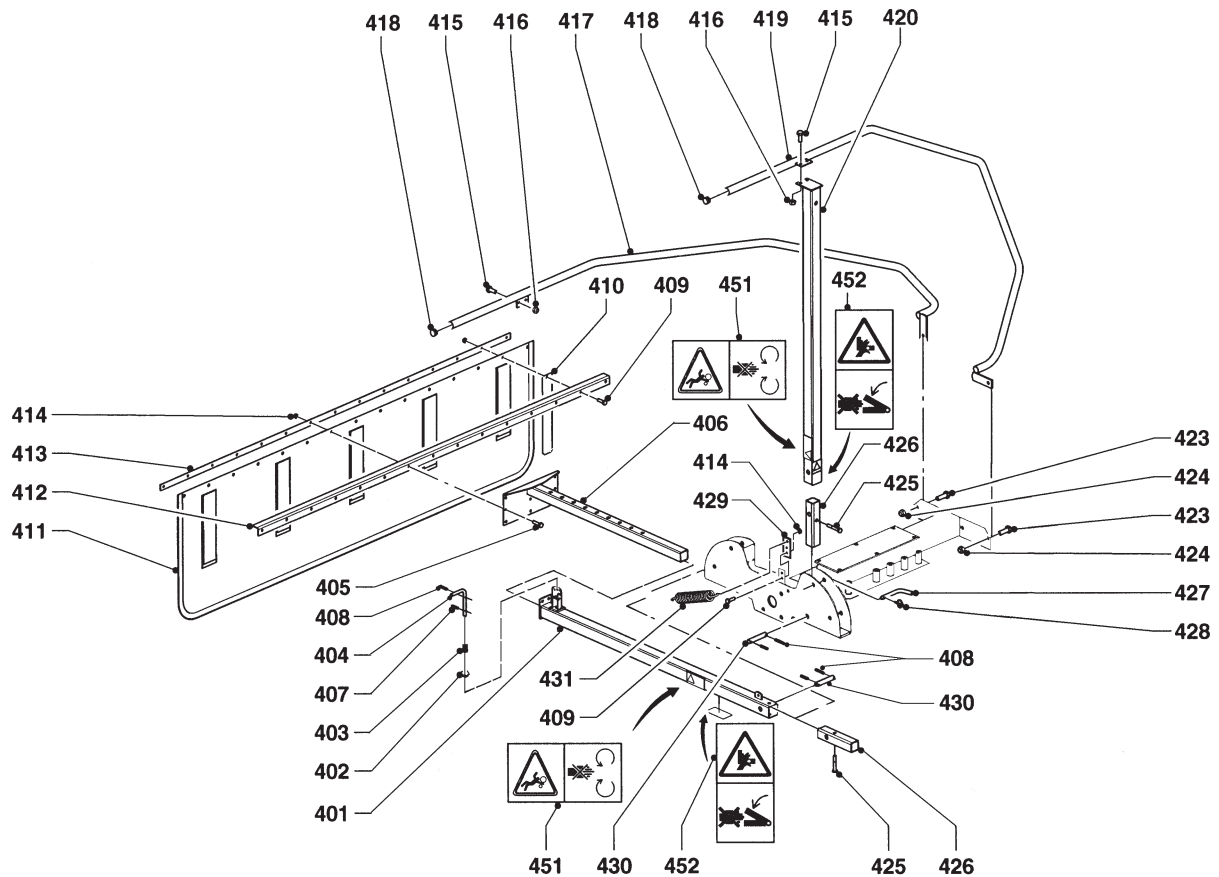
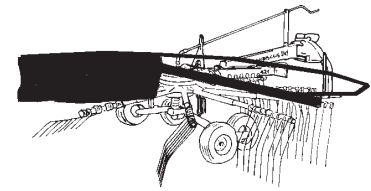

B204.01.20

REF.	ONDERDEELNR. PART NUMBER REFERENCE TEILNUMMER	AANTAL QUANTITY QUANTITE ANZAHL		
------	--	--	--	--

401	4.1042.1101.0	1	[L]	
402	9.1048.0012*6	1	A13 DIN 125	[—]
403	4.1002.0093.0	1		
404	4.1207.0188.0	1		
405	9.1113.0130*3	3	M8x30 DIN 933-8.8	
406	4.1042.1120.0	1		
407	9.1070.0049.0	1	Ø6x24 DIN 1481	
408	9.1070.0017.3	5	Ø6x30 DIN 1481	
409	9.1113.0128*1	14	M8x25 DIN 933-8.8	
410	4.1042.1503.0	5		
411	4.1042.1500.0	1		
412	4.1042.1501.0	1		
413	4.1042.1502.0	1		
414	9.1030.0012*3	17	M8 DIN 985-8	
415	9.1113.0029*0	4	M10x25 DIN 933-8.8	
416	9.1030.0004*2	4	M10 DIN 985-8	
417	4.1042.1080.0	1	[L]	
418	9.1108.0085.6	2	Ø32	
419	4.1042.1090.0	1	[R]	
420	4.1042.1111.0	1	[R]	

423	9.1113.0125*5	2	M12x35 DIN 933-8.8	
424	9.1030.0013*4	2	M12 DIN 985-8	
425	9.1113.0060*3	2	M12x75 DIN 931-8.8	
426	4.1042.1497.0	2		
427	4.1003.0142.0	2		

REF.	ONDERDEELNR. PART NUMBER REFERENCE TEILNUMMER	AANTAL QUANTITY QUANTITE ANZAHL	
------	--	--	--

428	9.1123.0003*6	2	Ø6
429	4.1042.1053.0	1	
430	4.1042.1220.0	2	
431	1.1633.1496.0	1	
451	9.1170.0407.6	2	
452	9.1170.0437.1	2	

LELY

HIBISCUS	type number type number numéro de type Typnummer	vanaf serienummer as from serial number après numéro de série ab Seriennummer
421	4.1042.0000.1	10413 - 0501

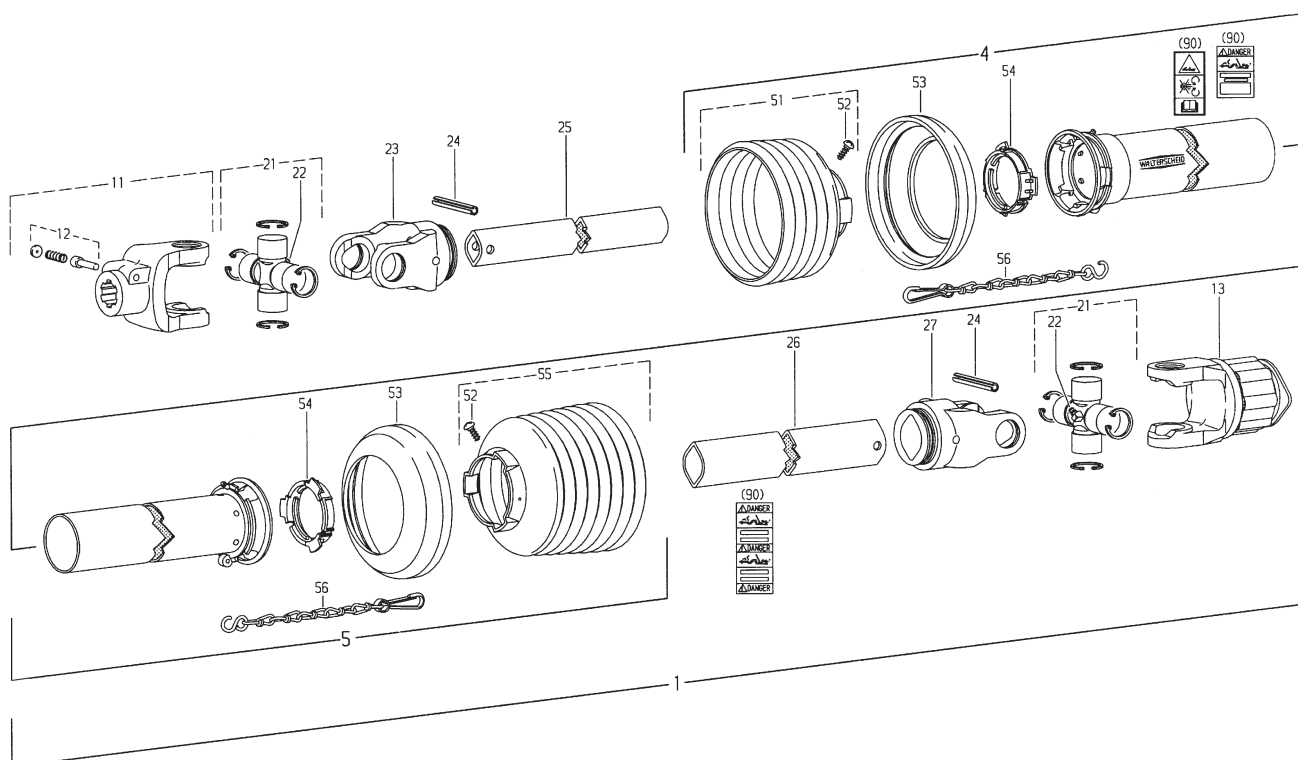
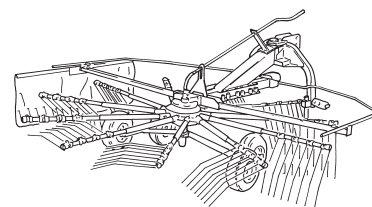

Bw008.01.10

REF.	ONDERDEELNR. PART NUMBER REFERENCE TEILNUMMER	AANTAL QUANTITY QUANTITE ANZAHL	
------	--	--	--

1	9.1154.0201.5	1	W2102-SD05-860-K32B - 330Nm = REF. 11-90
4	85.005	1	SDH05-A750-RP6-K
5	85.004	1	SDH05-J750-RP10-K
11	10.10.00	1	1.3/8" (6)
12	33.91.07	1	AGRASET 101
13	55.288.03	1	K 32 B-2100-1.3/8" (6)ZV; M= 330 Nm
21	10.01.00	2	
22	63.27.00	2	BM8x1
23	10.48.00	1	RG2100-00a
24	9.1070.0023.2	2	Ø8x50 DIN 1481
25	75.06.15	1	00a-760
26	75.12.15	1	0a-755
27	10.49.00	1	RG2100-0a
51	85.05.05	1	n= 5
52	60.15.00	2	4x10
53	83.10.03	2	
54	83.09.01	2	
55	85.05.07	1	n= 7
56	82.36.03	2	
90	11.87.45	1+1+1	Cpl.

REF.	ONDERDEELNR. PART NUMBER REFERENCE TEILNUMMER	AANTAL QUANTITY QUANTITE ANZAHL	
------	--	--	--